

Ongoing Developments of Magnetic Measurement Equipment for Undulators at DESY

Jacques Abenheim, Paul Neumann, Andreas Schöps, Sayali Telawane, Markus Tischer, Pavel Vagin
on behalf of DESY's Insertion Device group (FS-US)

IMMW22, CNPEM - Campinas, 30.09.2022

Topics

- > Introduction
- > In-situ measurement bench for IVUs and CPMUs at PETRA-IV
- > SW setup for characterization of magnet keepers of APPLE-III undulators for FLASH2020+
- > Measurement electronics for data acquisition

> Undulator/PM Group at DESY

- Jacques Abenhaim
- Philip Eckoldt
- Mona Gehlot
- Kathrin Götze
- Paul Neumann
- Patrick N’Gotta
- Andreas Schöps
- Sayali Telawane
- Markus Tischer
- Pavel Vagin
- Thorsten Vielitz

Ada Yonath Hall
Extension Hall East



Max von Laue Hall

Paul P. Ewald Hall
Extension Hall North

In-situ Measurement Bench

Compact Hall-probe system for IVUs and CPMUs

Motivation for PETRA IV high energy beamlines

- Required for final site acceptance tests of IVUs in fully assembled state,
- Shall also be used for final measurements and tuning steps on CPMUs,
- Thus, has to work under vacuum and cryogenic conditions,
- Similar systems already operated at other facilities (e.g. HZB, Soleil, ESRF, NSRRC, HEPS,...).

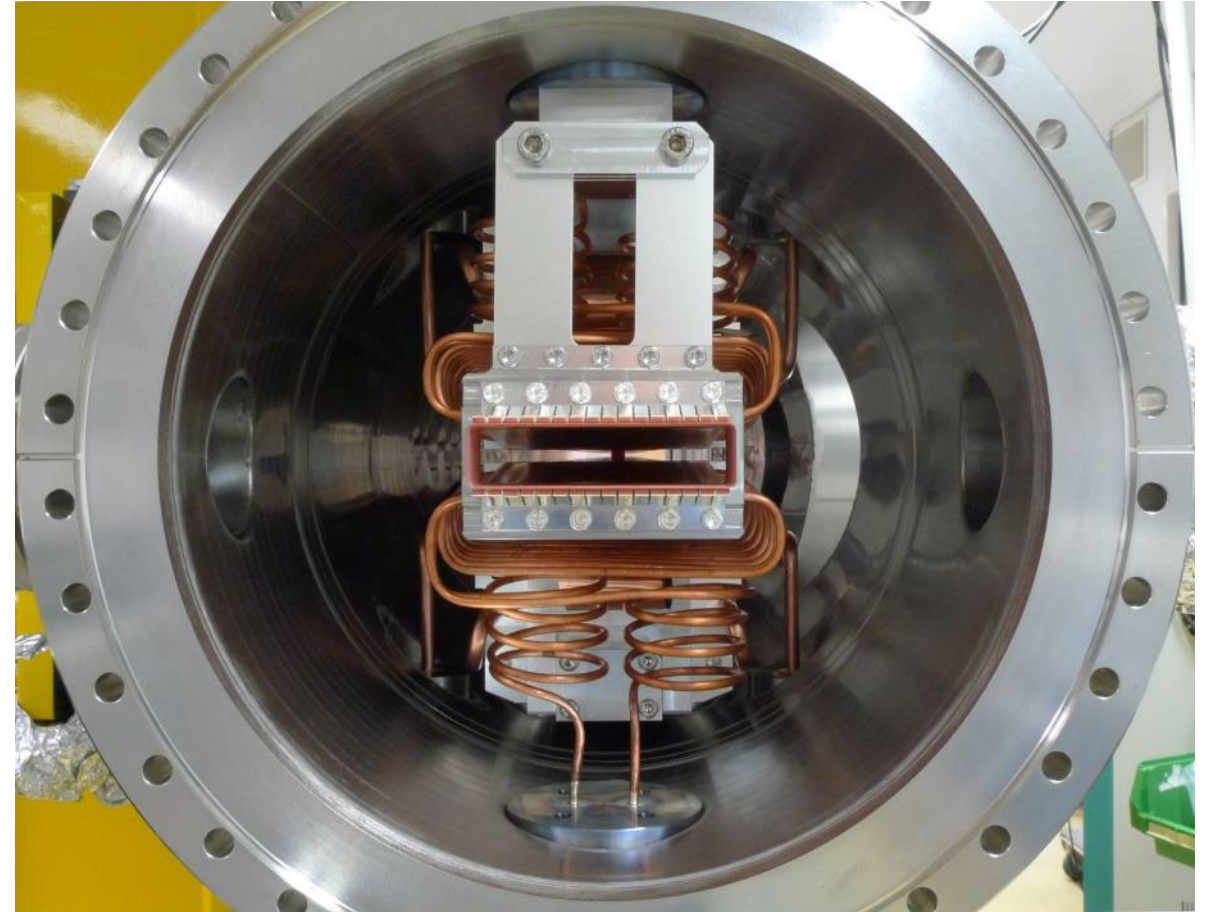

SAFALI system principle (sketch)

Self Aligned Field Analyser with Laser Instrumentation

- Compact Hall-probe measurement system (SPring-8 design),
- Does not rely on mechanical accuracy of main drive axis,
- Deviations from ideal Hall-probe position are measured and corrected for,
- In-situ operation (cryogenic / in-vacuum).

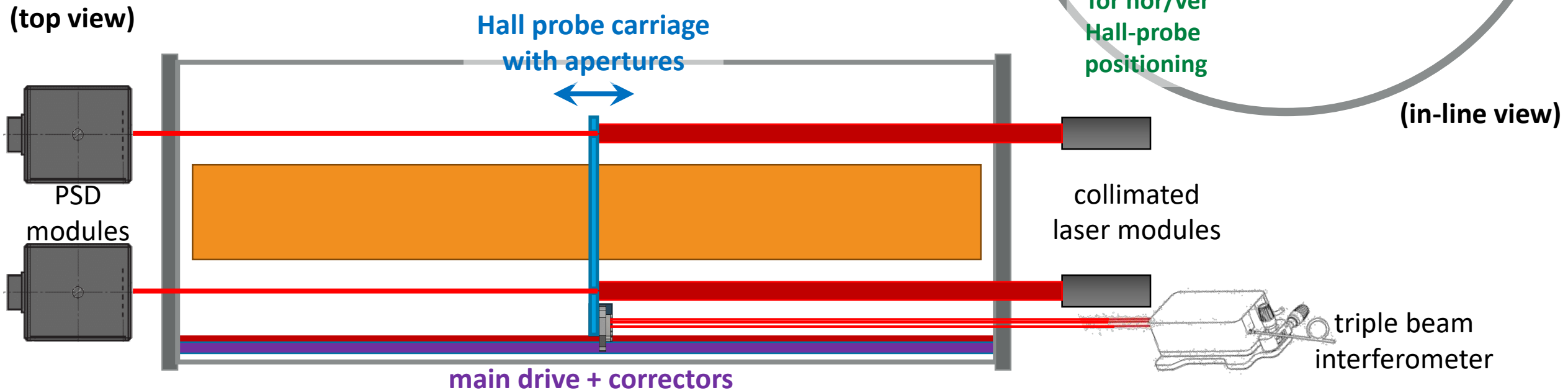

SAFALI system

Engineering and realisation

- Main drive axis with vacuum compatible spindle and guide rails,
- Piezo stages for horizontal and vertical position corrections,
- Evaluating innovative spring driven cable reel system.

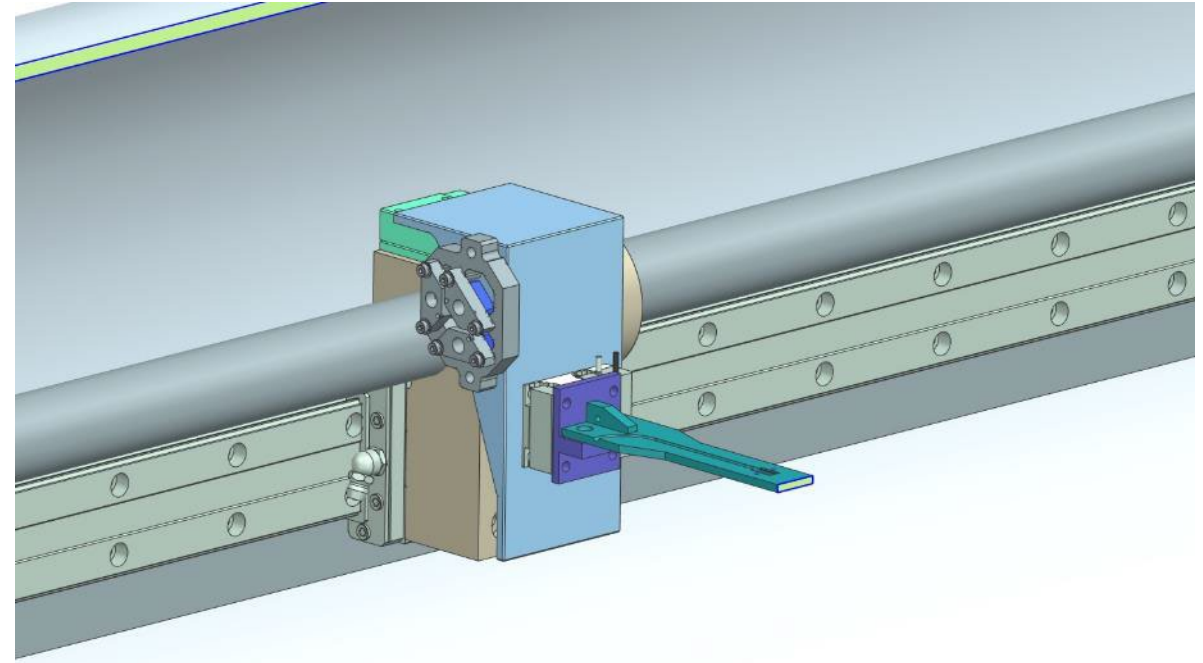

SAFALI axis / angle	Position measured by	Measures
Along the beam	Interferometer	Active position feedback for main axis
Perpendicular to beam	hor. / ver. PSD signal	Active position feedback for piezo correctors
Roll (around beam)	diff. of ver. PSD signals	Correct magnet data
Pitch / Yaw	Interferometer	Correct magnet / main axis position data

Characterization of APPLE-III Magnet Keepers

APPLE III – Concept and Overview

for FLASH2 Afterburner and FL2020+ Seeding IDs

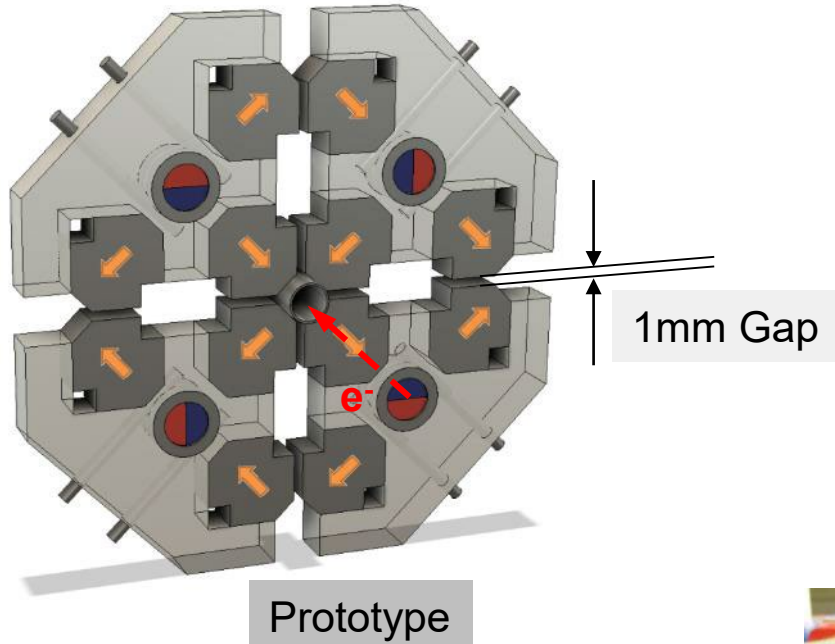

- Force compensation scheme
- Short prototype: $\lambda_U=16\text{mm}$, $N=16$
...iterated \rightarrow
- FL2 afterburner: $\lambda_U=17.5\text{mm}$, $L=2.5\text{m}$
- “Full period”-keepers

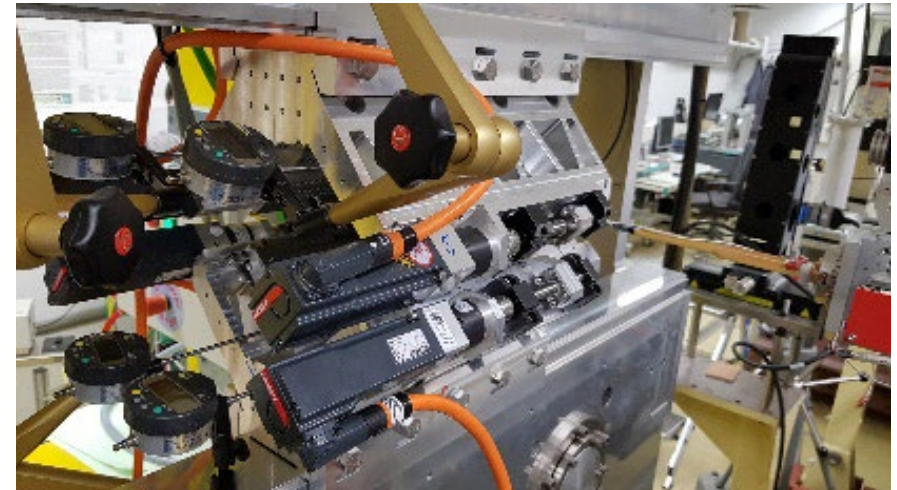
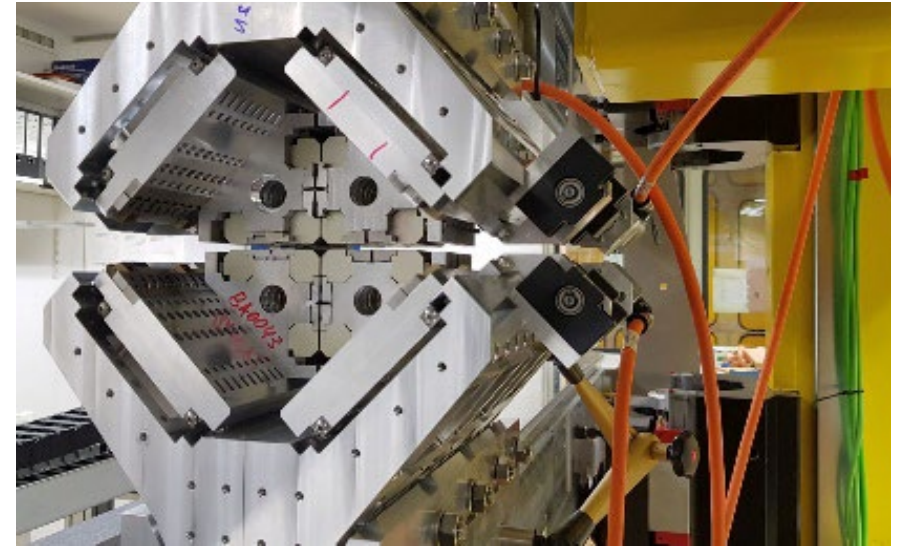

Combined (glued) Single Magnets

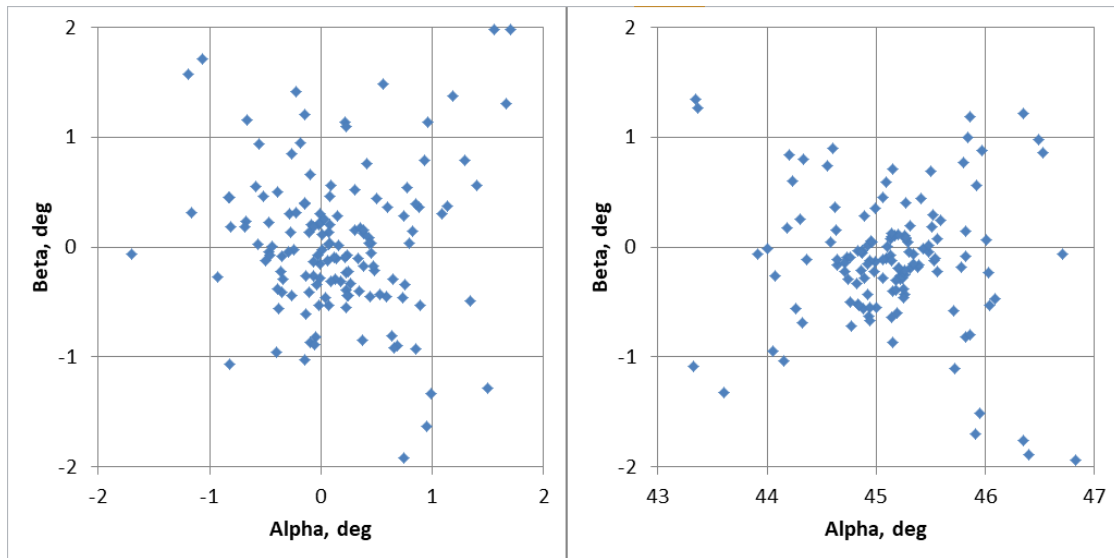
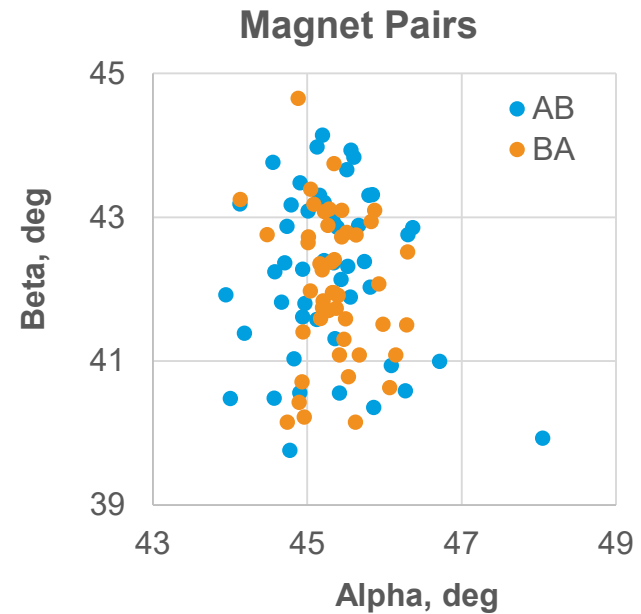
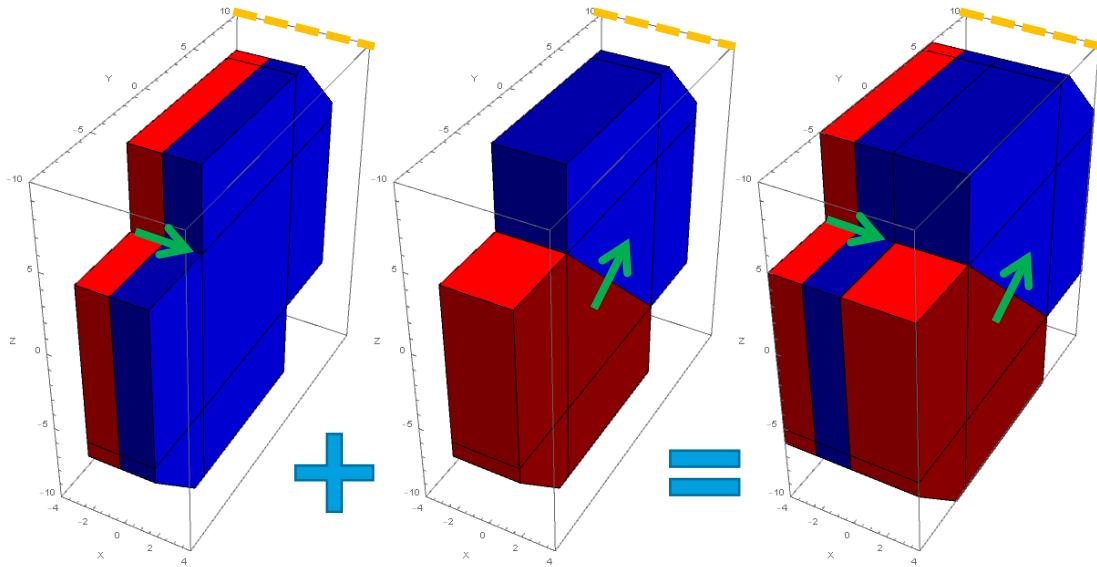

- Magnet sorting of single magnets (only for prototype)
- Magnetic errors of single magnets are similar to usual magnets $\sim 0.7^\circ$ rms, despite of smaller magnets and 45° magnetization direction
- Angular error after gluing slightly increased to 1.2° rms, absolute values of magnetization angle cannot be interpreted directly

Magnet – Manufacturing & Characterization

> Fabrication of magnet pairs (specification to vendors)

- Production of both, single A and B magnets from die-pressed TP-material
- Magnet errors: 1% Mr scatter and 1.5° angular errors
- GBD treatment for all single magnets
- Gluing of single magnets to AB-pairs in *fully randomized* configurations
- Coating of magnet pairs

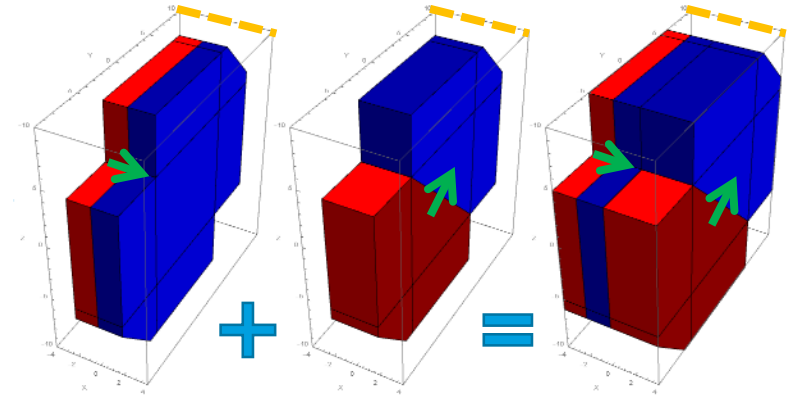

> Magnetic measurements

- Helmholtz coil measurements of completed AB- and BA-magnet pairs
- Hall mapper (“camera”) measurements of magnets (possibly)
- Short stretched wire stand for assembled magnet keepers
 - direct measurement of field integral errors on-axis
 - additionally Hall probe for field amplitude/phase error

> Magnet structure assembly

- Sorting of keepers based on Helmholtz, SW and Hall probe data
- Magnetic measurement and pre-shimming of upper and lower girders separately

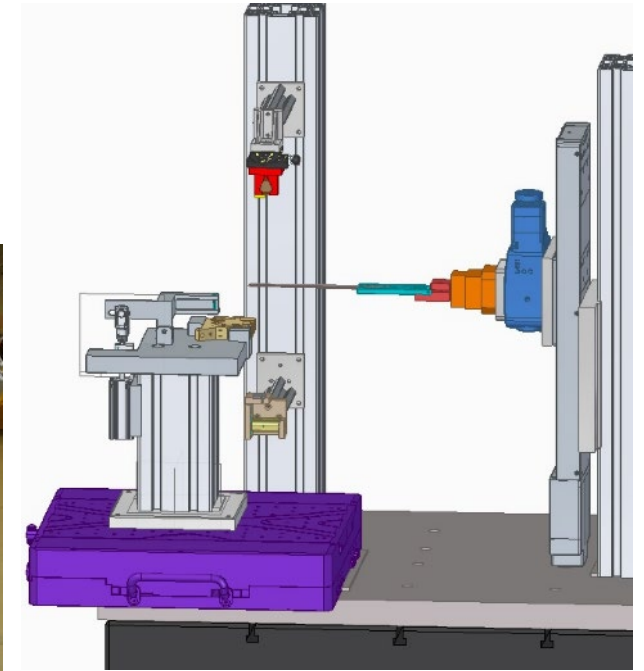
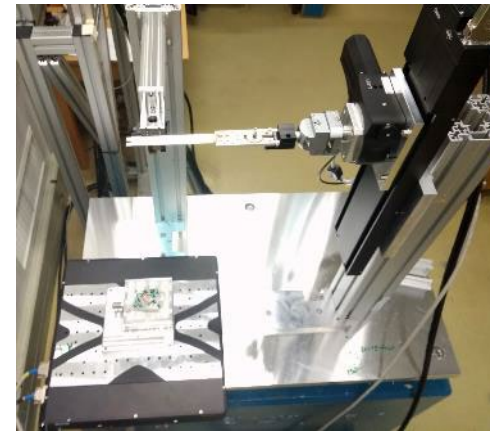

Measurement Electronics for Data Acquisition

Helmholtz coil measurements of magnetic moment

- > Large 1D Helmholtz coils (KYMA)
 - Motorized magnet rotation to get other components
- > Small 3D PCB coils
 - ~100x100mm, 10 turns
 - Manual movement of the coil on to the magnet

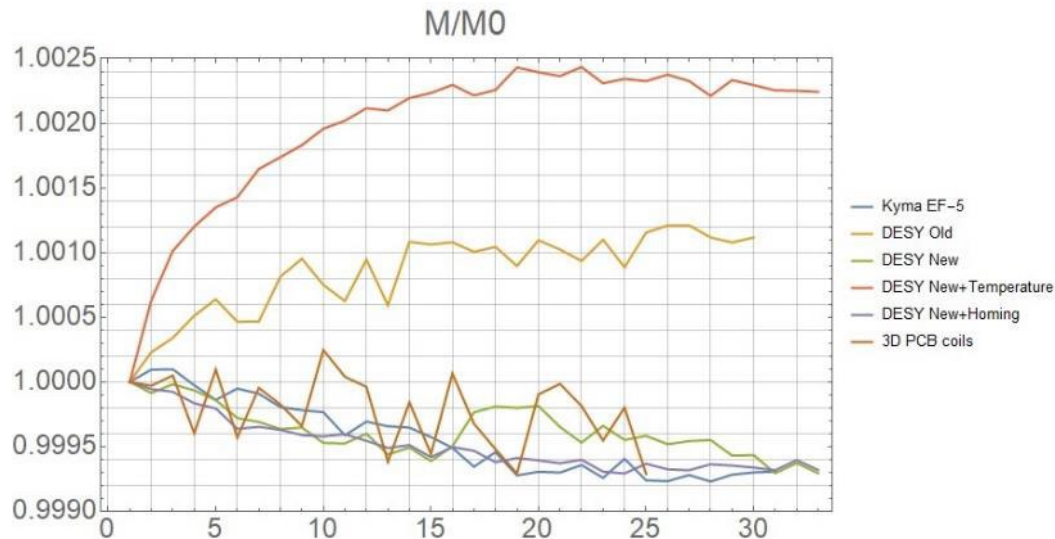
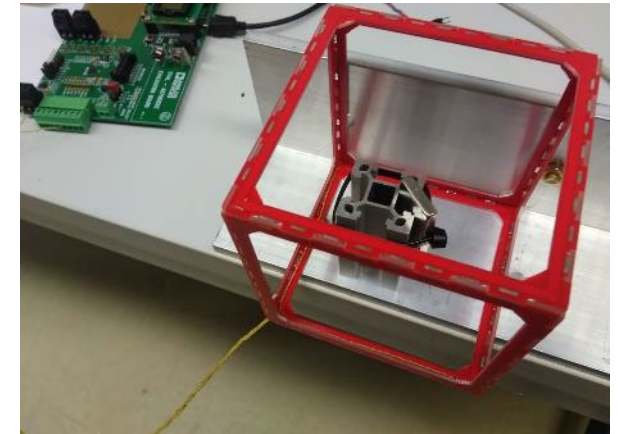

Reproducibility <0.05% & <0.5mrad

Main problem is temperature stability of NdFeB ~0.1%/K

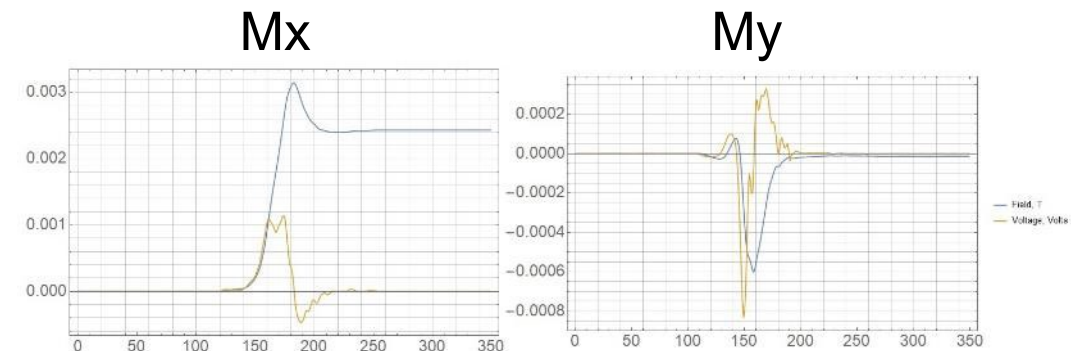

Hall mapper

10mm pitch, 8x8 array

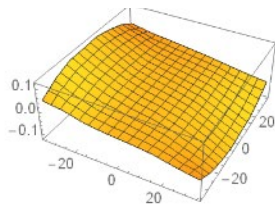
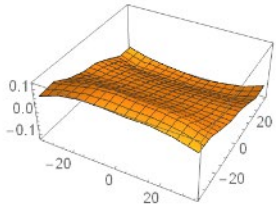
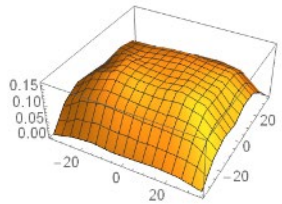
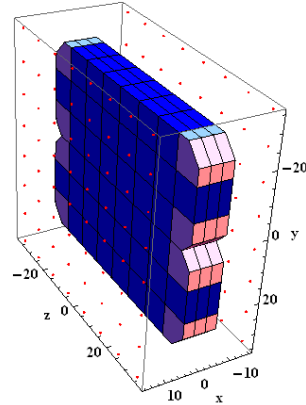
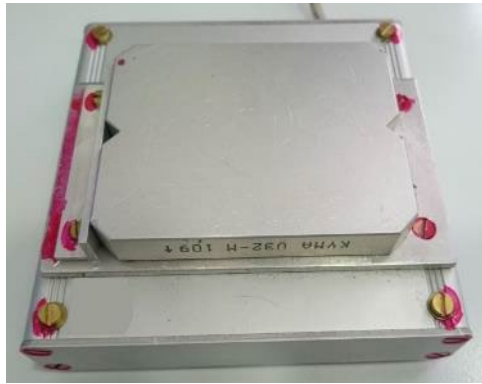

Prototyping of upgraded version
New TMAG5273 sensors, 3mm pitch, 24x24

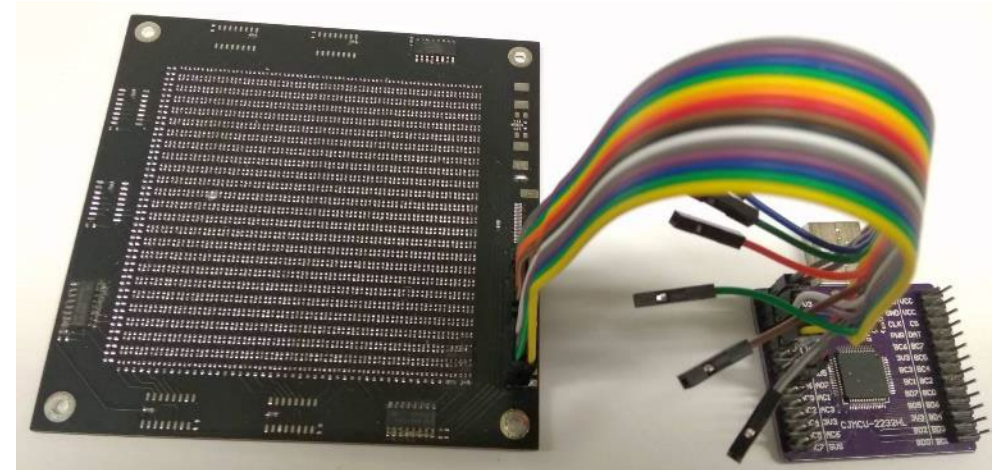

Phase shifter

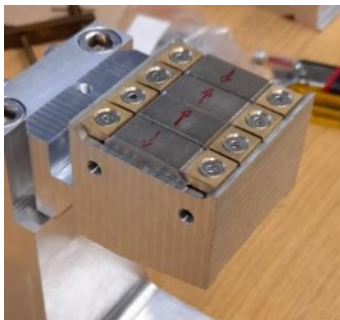

Transverse dependence of field integrals, direct wire measurement vs prediction from mapper

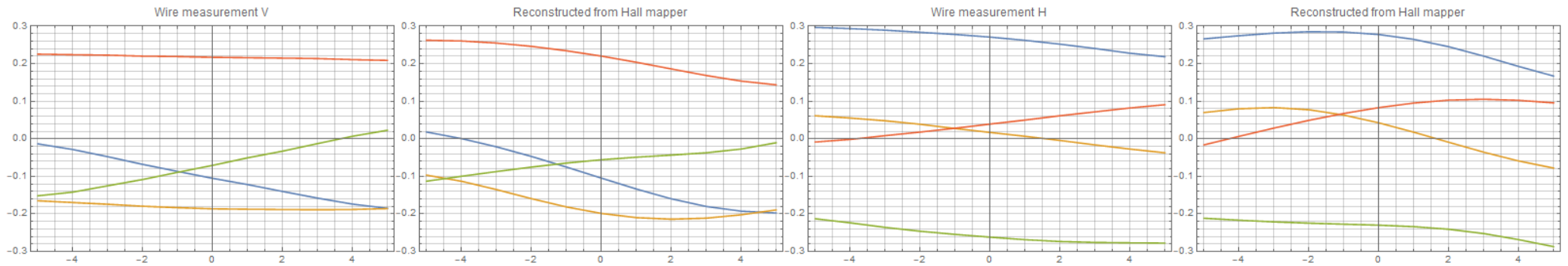

Voltmeter noise

Voltage integral

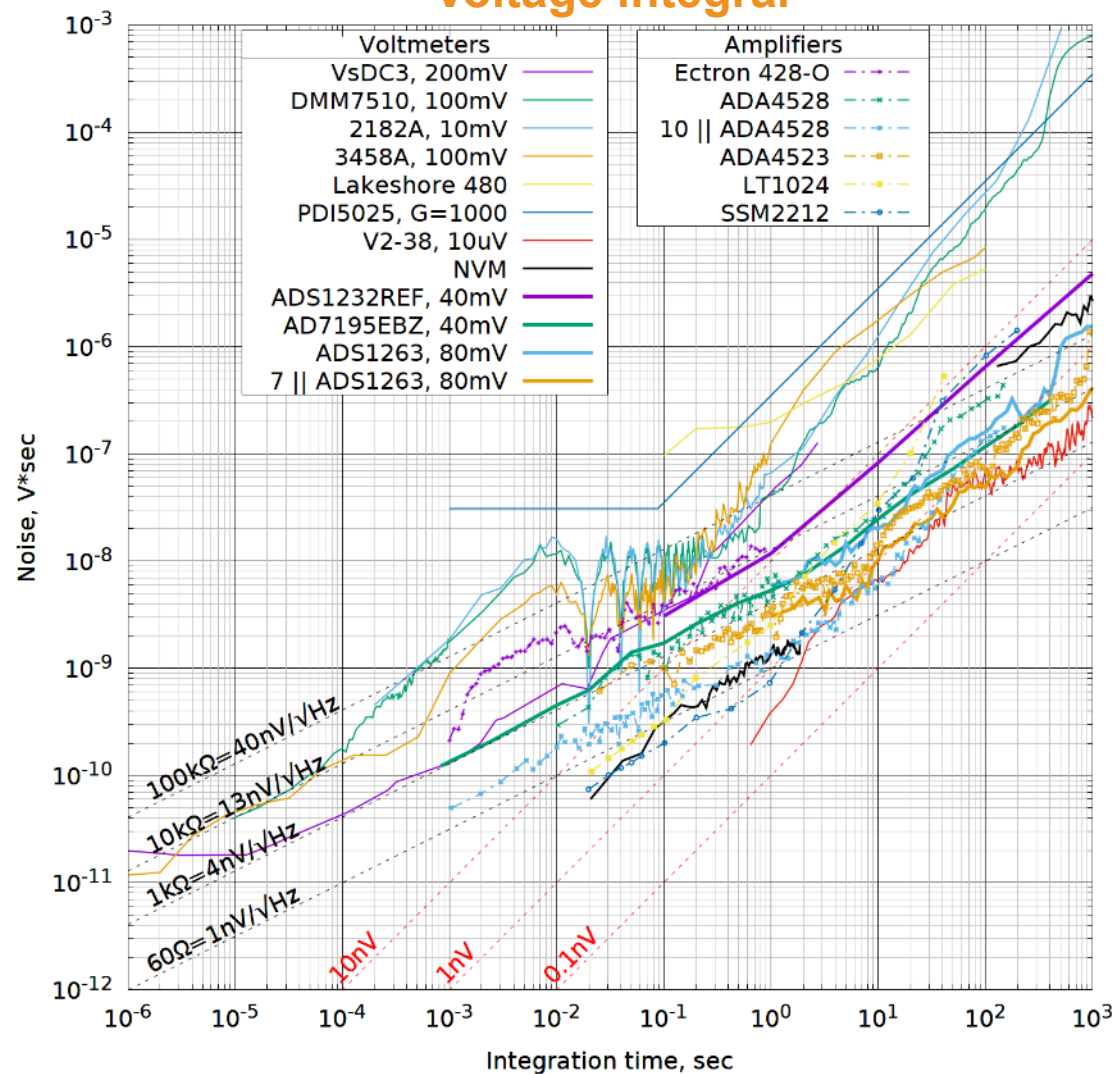

Voltage

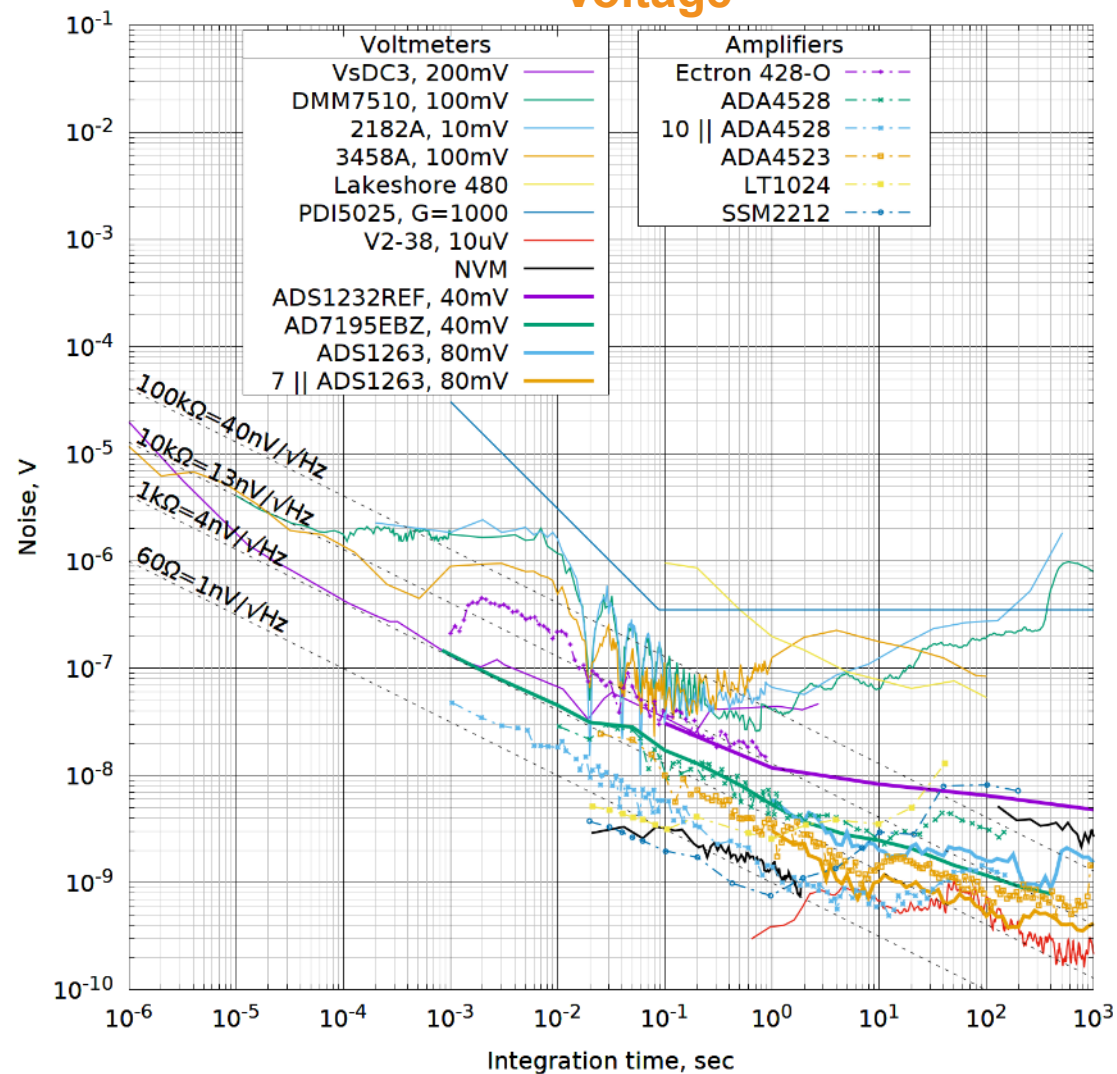

Parallel operation to reduce noise level further

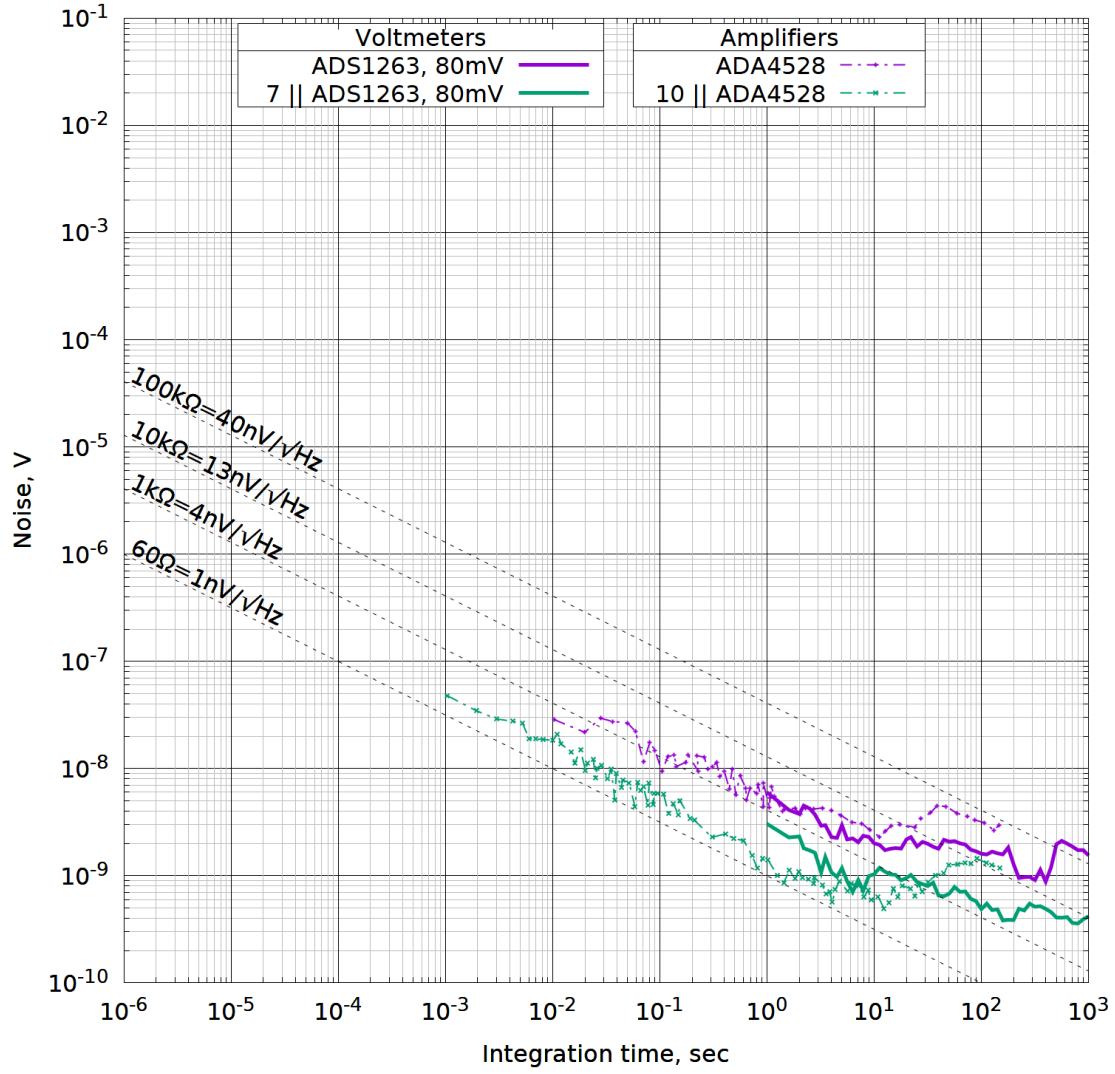
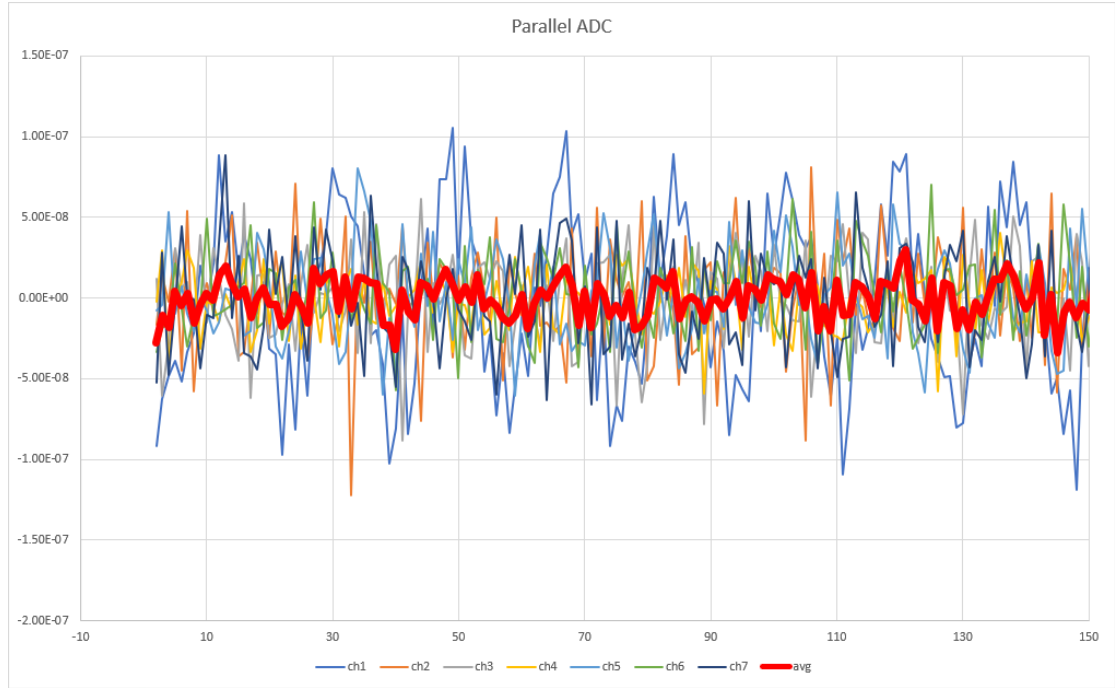
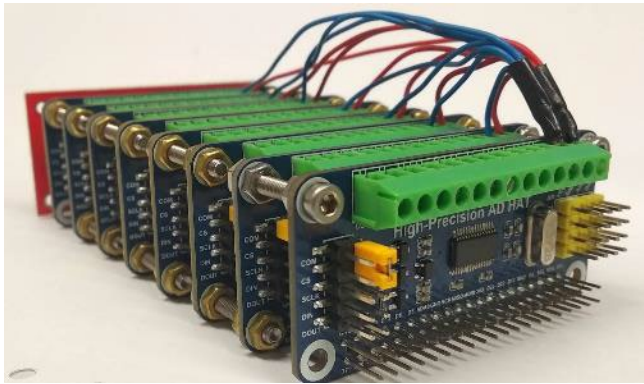
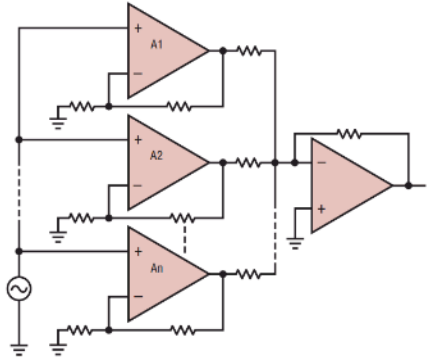

Hall probe bench triggering

- Up to 0.3T/mm field gradient, 1 μ m = 300 μ T field error
- Fortunately positioning jitter errors do not really accumulate in field integral errors

Sampling of 40 μ m sin/cos encoder signal with HP3458 by external trigger from motion control system

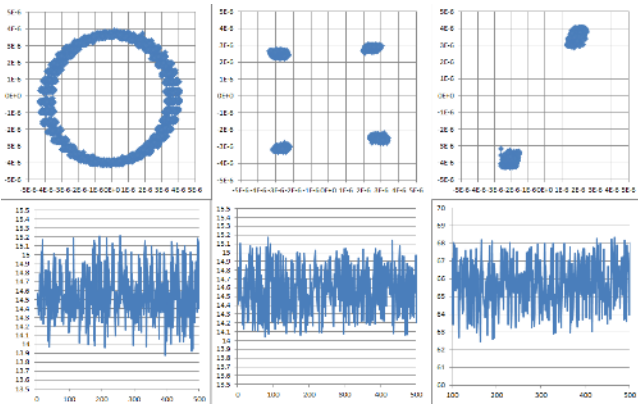

Speed, mm/s	Stdev, μ m
0.1	0.25
1	0.25
10	1.4
100	5.4

ADS1278EVM 8-channel simultaneous sampling of 3D hall probe & sin/cos encoder output

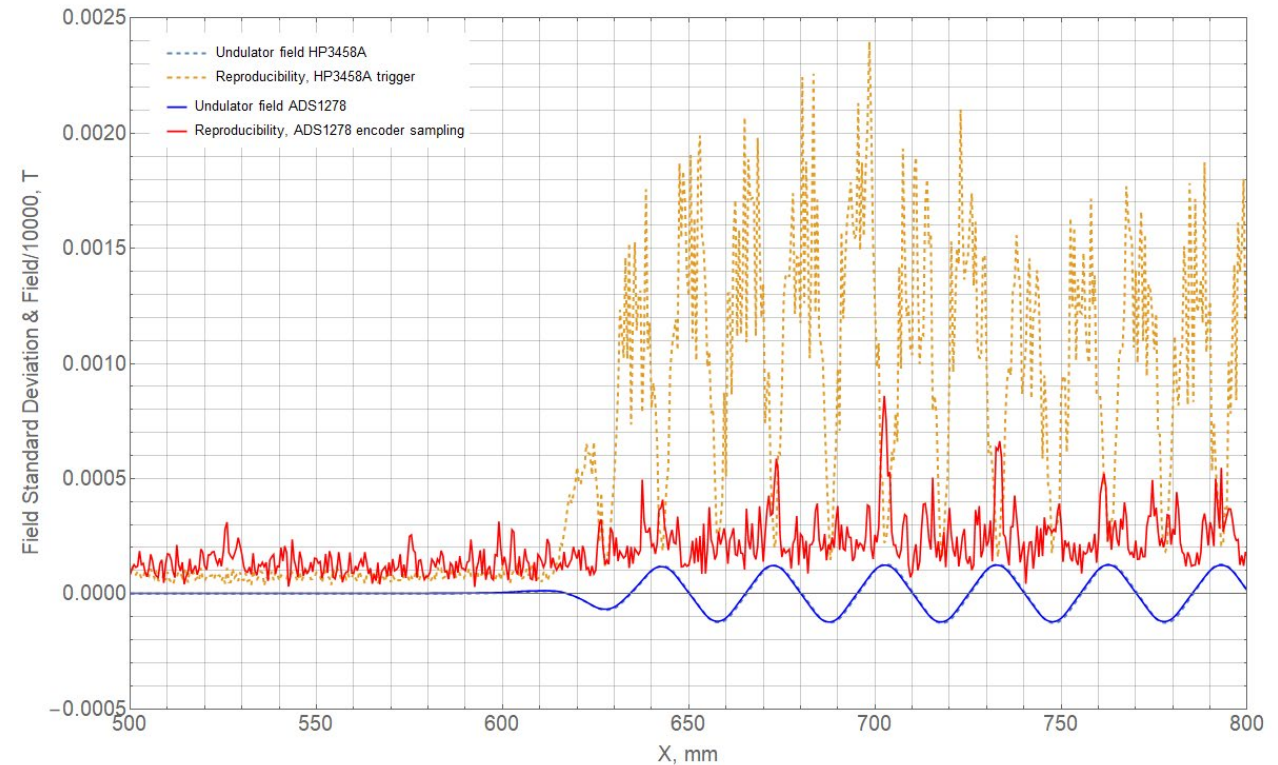

Hall probe holder vibration

Using undulator field gradients as magnetic position encoder

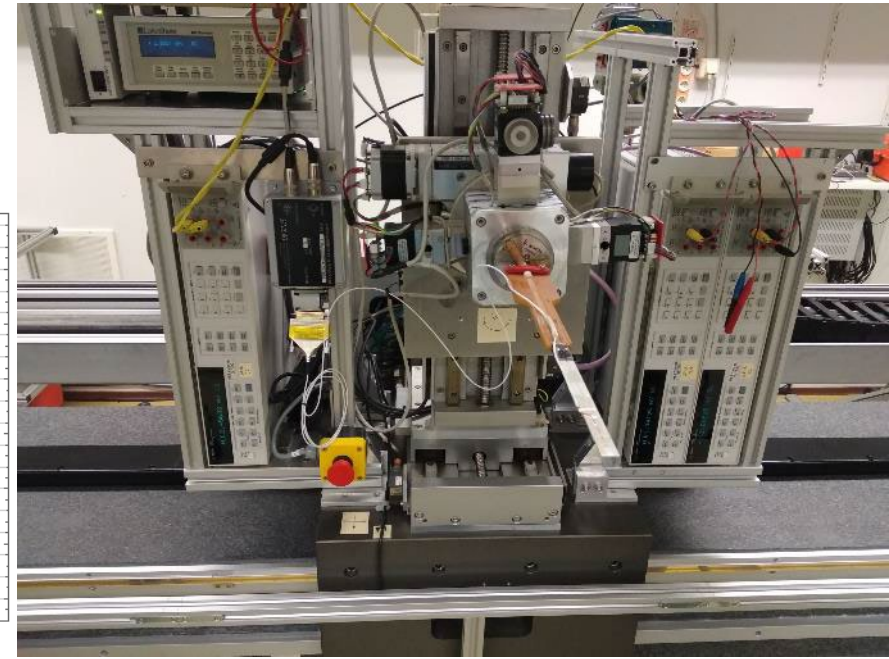
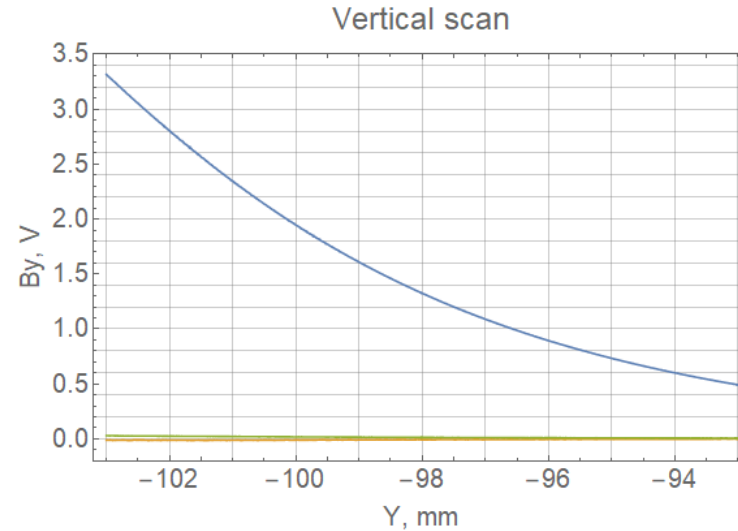
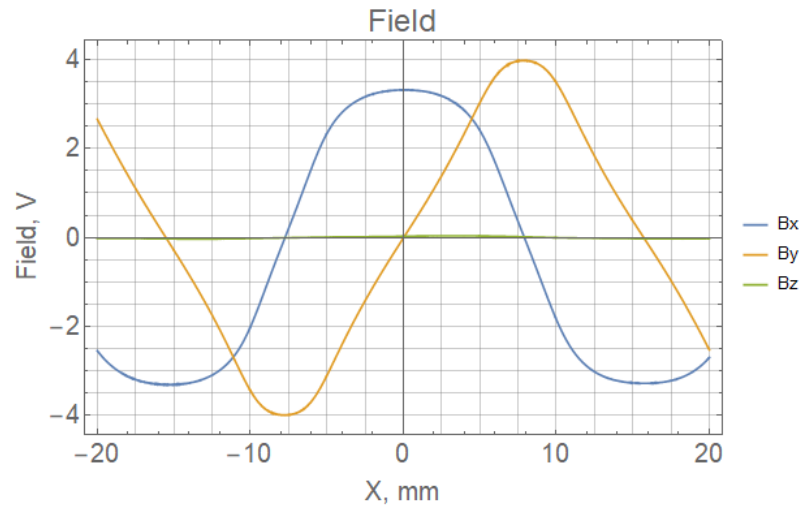

Probe vibration for different pressure settings of air cushion bearing of bench moving platform

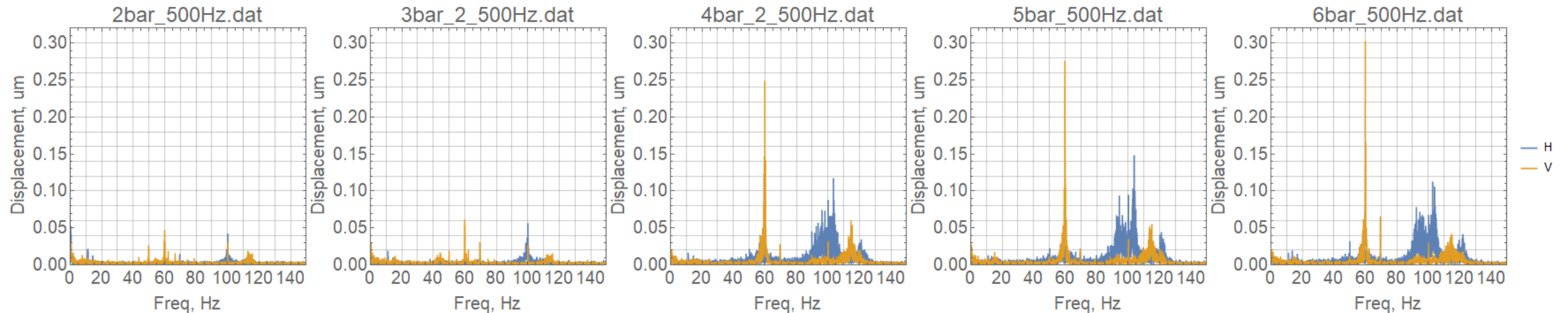

Hall probe holder vibration, additional damping

Additional small weight changes the probe holder vibrations

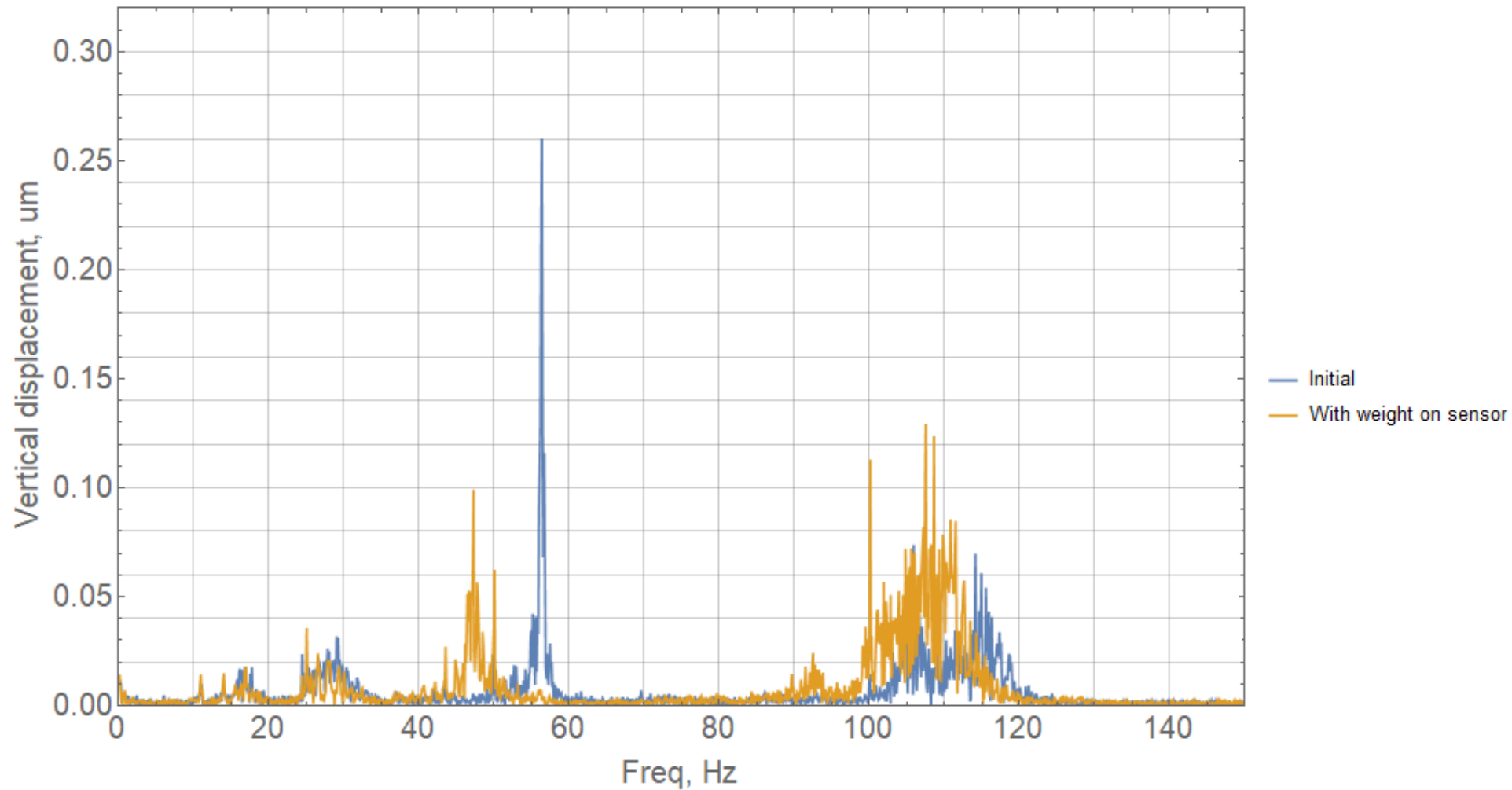

Granite bench straightness

Measured with water level

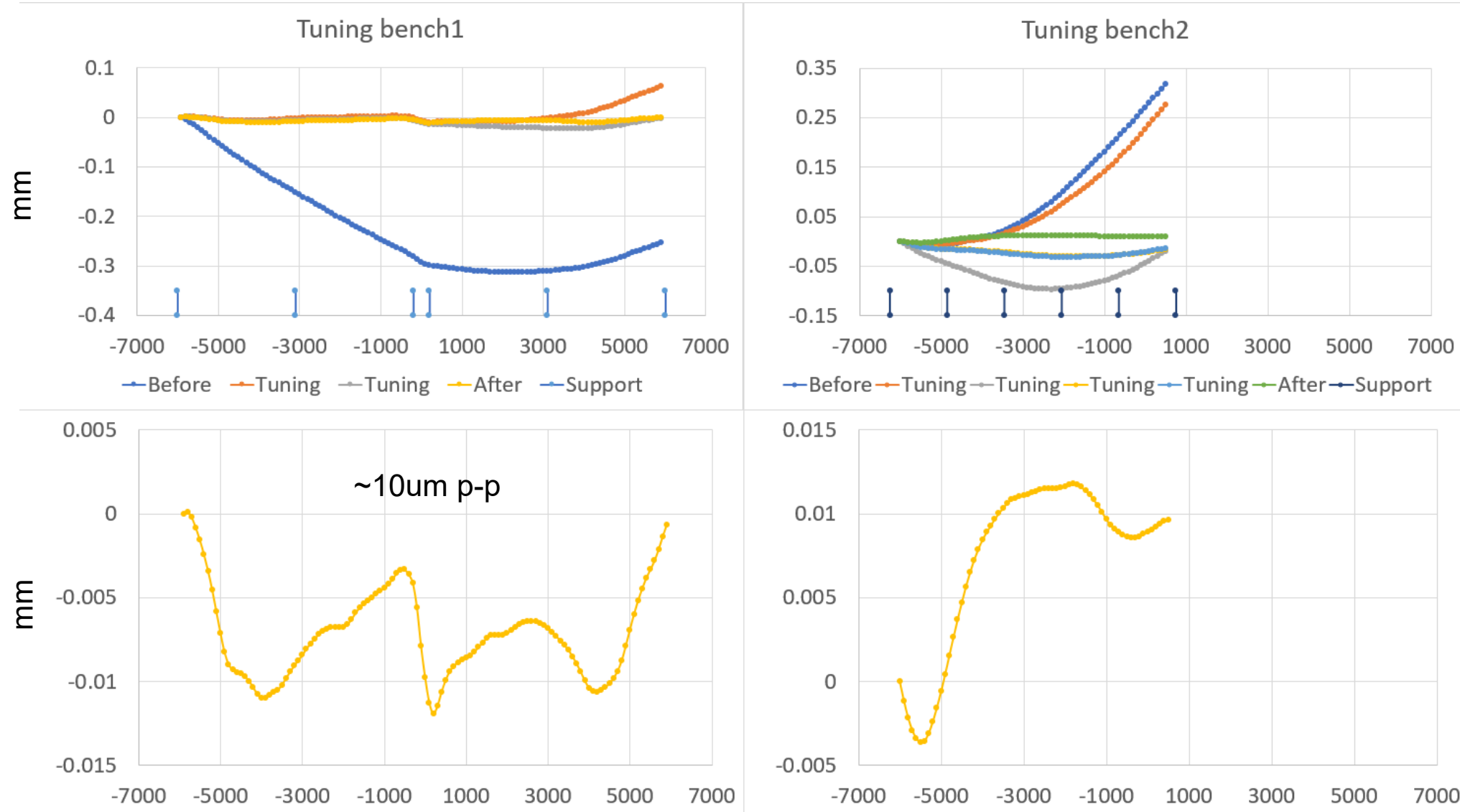

Thank you