



# Magnetic Measurements at Diamond Light Source

Z. Patel

S. Milward, A. Ramezani Moghaddam, G. Sharma, S. Tripathi

# Diamond-I upgrades

## Upgrading crystallography beamlines:

- CPMU1 → I24 (2020)
- CPMU2 → I03 (2021)
- CPMU3 → I24 (2021)
- CPMU4 → I04 (2022)
- HPMU1 → I04-1 (2022)

All CPMUs designed, built, & measured in-house

- 17.6 mm period, 113 periods
- HPMU procured from Kyma
- 19.7 mm period, 87.5 periods
- 2-4x more flux

## Near-future installations:

- CPMU1 → I11 (2023)
- CPMU5 → I02-1 (2023)

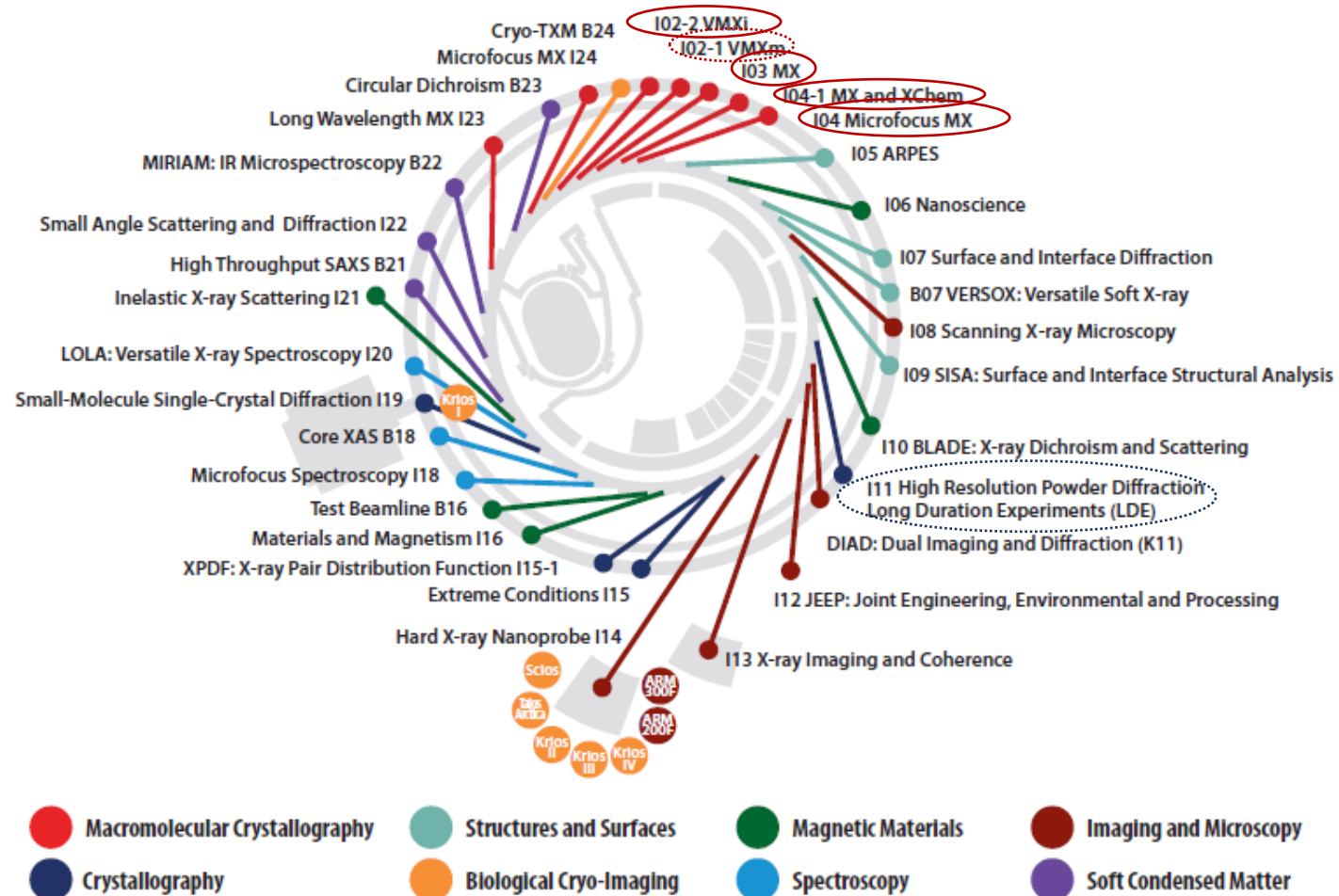

# Diamond-I upgrades cont...

CPMU1 foil bunched into gap when springs on foil tensioner were spring bound

- Springs were fully compressed when CPMU-1 was at room temperature
- Al magnet girders have shrunk by 7.86 mm at 77 K
- CuNi foil has shrunk by 5.23 mm and therefore bunches above the magnets
- Minimum gap restricted to 6.5 mm
- CPMU-1 replaced with CPMU-3
- CPMUs 2-4 had different springs & increased foil tension – no issue
- New foil & springs fitted on CPMU-1, next step cold measurements



Hole in foil at centre of girders following aperture scans at 5 mm gap due to foil bunching

Foil tensioner blocks

springs

0.1 mm thick CuNi foil

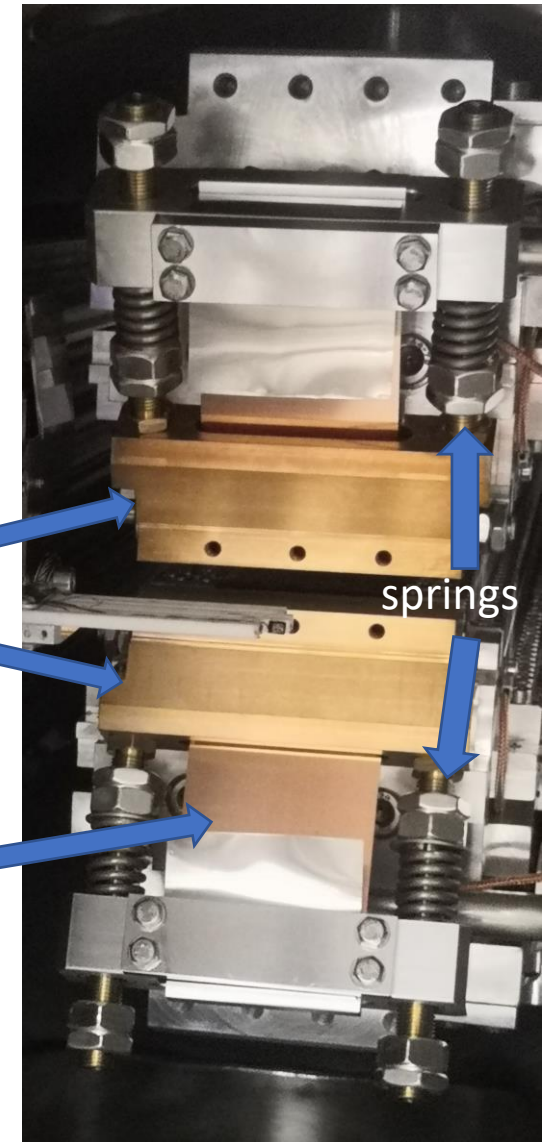

# Measurement systems

- 6 m out-of-vac bench: Hall probe & flipping coil. Can measure up to 5 m long devices
- 3 m out-of-vac bench: Hall probe & flipping coil. Can measure up to 2 m long devices
- 2.5 m in-vac cold bench: Hall probe & stretched wire. Can measure up to 2 m long devices
- Helmholtz coil for magnetic moment measurements

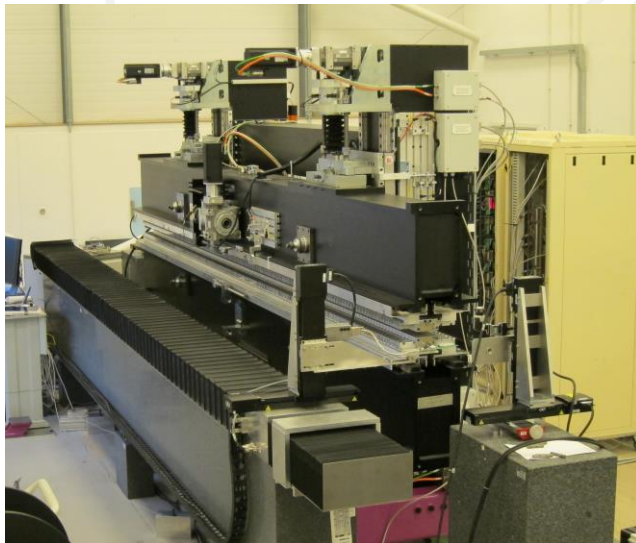

8 m out-of-vac bench with 5 m long ID I05



3 m out-of-vac bench with 2 m long CPMU-1

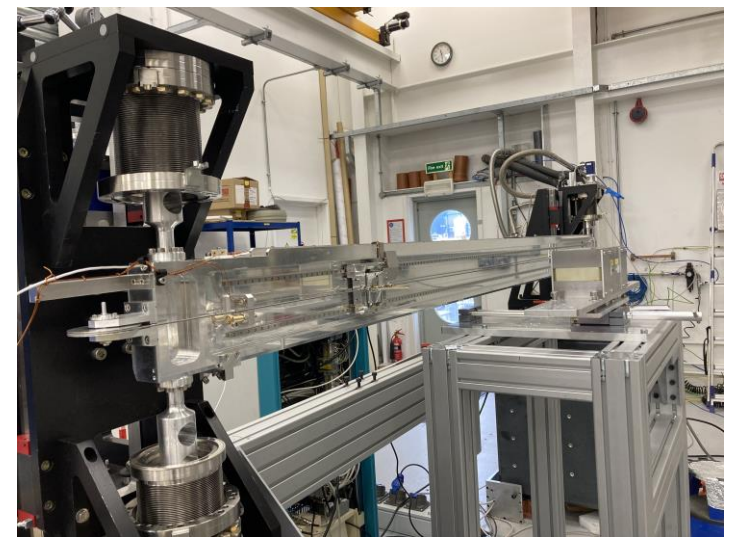

In-vac cold bench with dipole magnet

# Helmholtz coil

Parameter	Value
Radius	33 cm
K (Calibration Constant)	281.7386 A/T
K (Calibration Constant) or Measuring constant	0.0354 cm
Rotation frequency	1-3 Hz
Data acquisition	Panda Box
Encoder	Incremental, 40000 pulse/turn
Precision	0.05% - 0.01 degree

- Data acquisition updated to a Panda box
- Calibration constant found using coil with constant current
- Offset between our measurements and Vacuumschmelze measurements for the main field component due to calibration constant
- Minor components very sensitive to positional errors – magnet holder removed between samples 4 & 5

30/09/2022

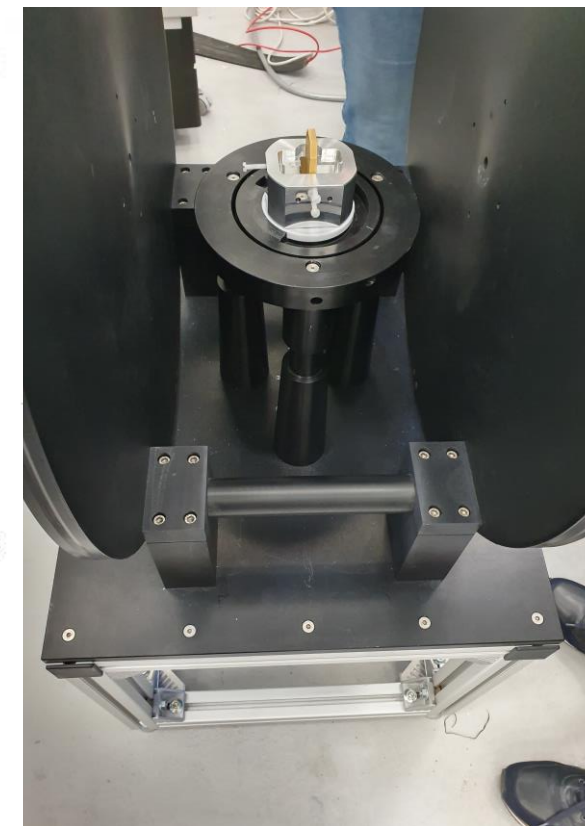
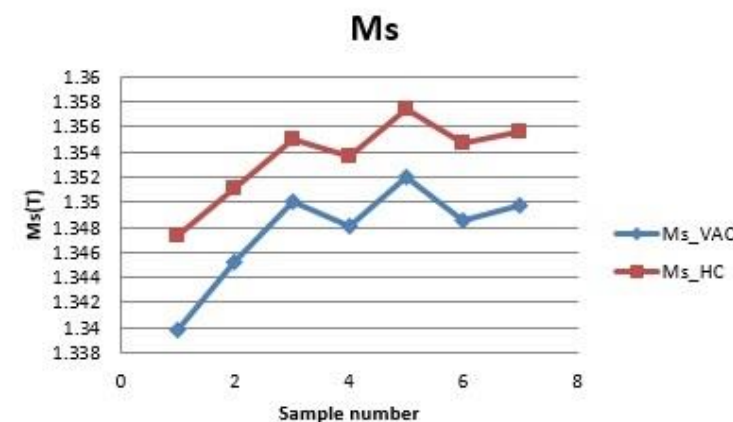
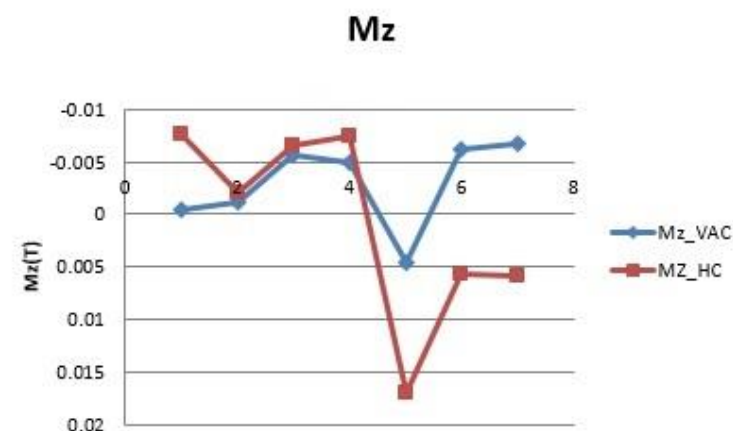
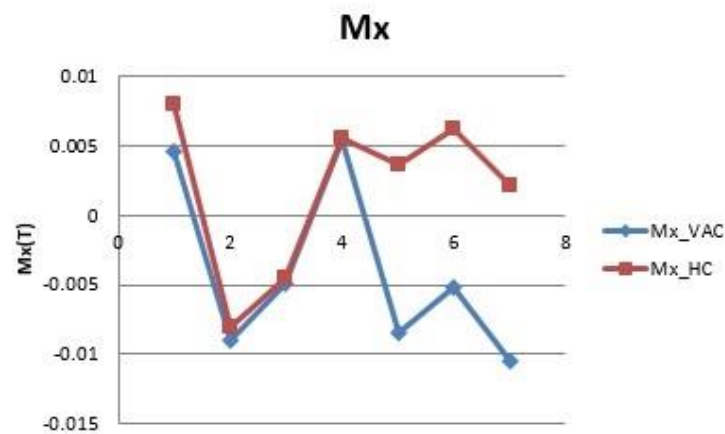

Supplied by Elletra

# In-vacuum cold bench

- Issues with 1<sup>st</sup> version changing when CPMU cooled → 2<sup>nd</sup> version
- Changed from triplet to doublet holders → could have a thicker Al beam
- 3 axis Hall probe runs via a pulley driven by out-of-vac stepper motor
- Beam mounted on two vertical stages rather than three manual stages (v1)
- Attached through bellows on extra vacuum vessels
- Laser interferometer for positioning

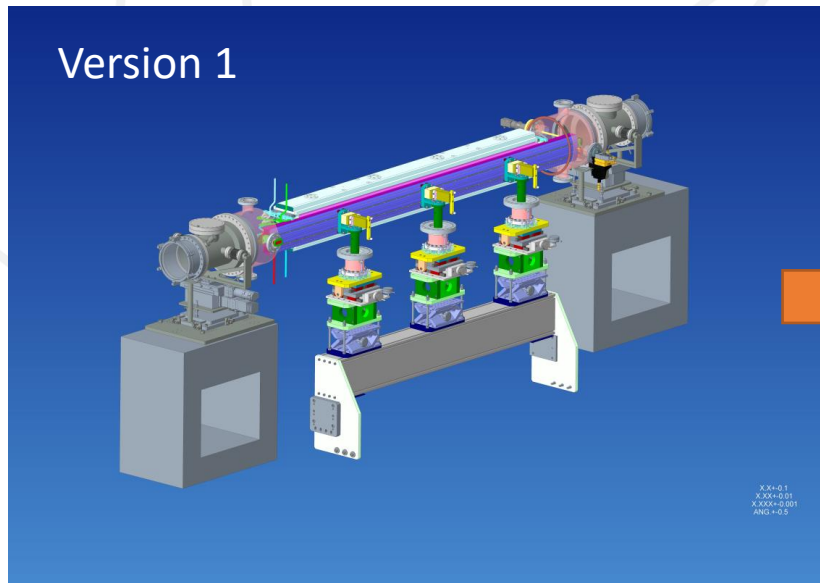

30/09/2022

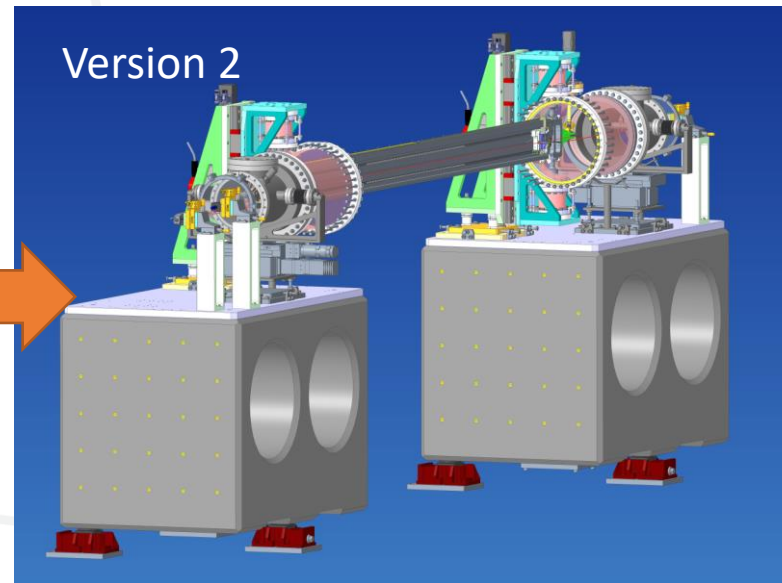

IMMW22

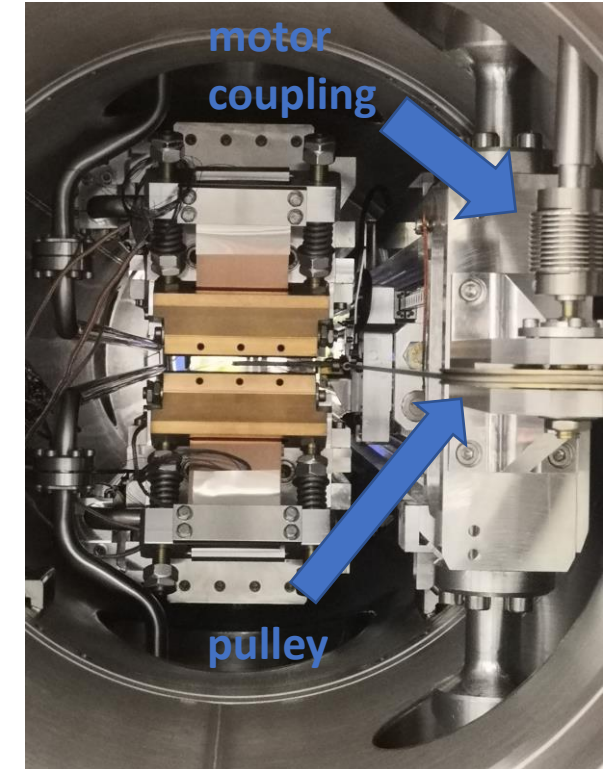

# In-vacuum cold bench: Hall probe

- CPMUs 1-3 measured using an Arepoc probe ( $\sim 1\text{V/T}$ ) down to a 5 mm gap
- CPMU-4 measured using SENIS I3C probe ( $5\text{ V/T}$ ) down to a 5 mm gap
- Calibration including angular errors of the SENIS probe done by SENIS
- Probe thickness restricted to 1.3 mm less than the ID gap by foil curvature along length of the CPMU

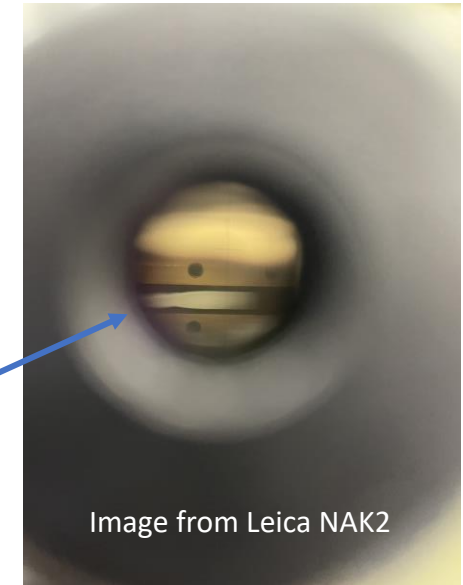

SENIS probe in 3 mm thick  
epoxy glass mount

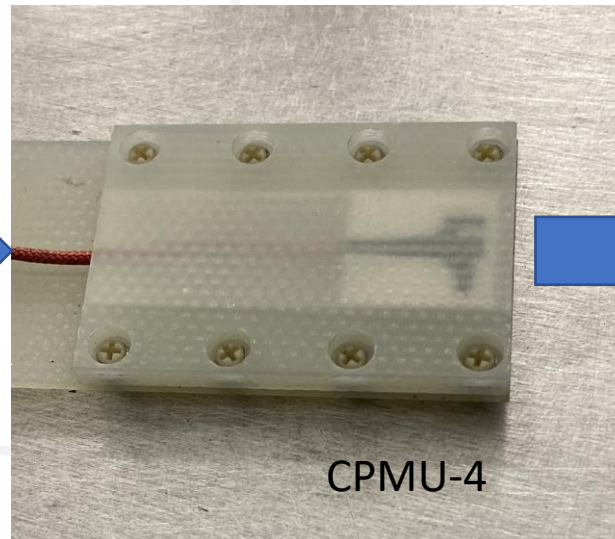

IMMW22



# In-vacuum cold bench: Stretched wire

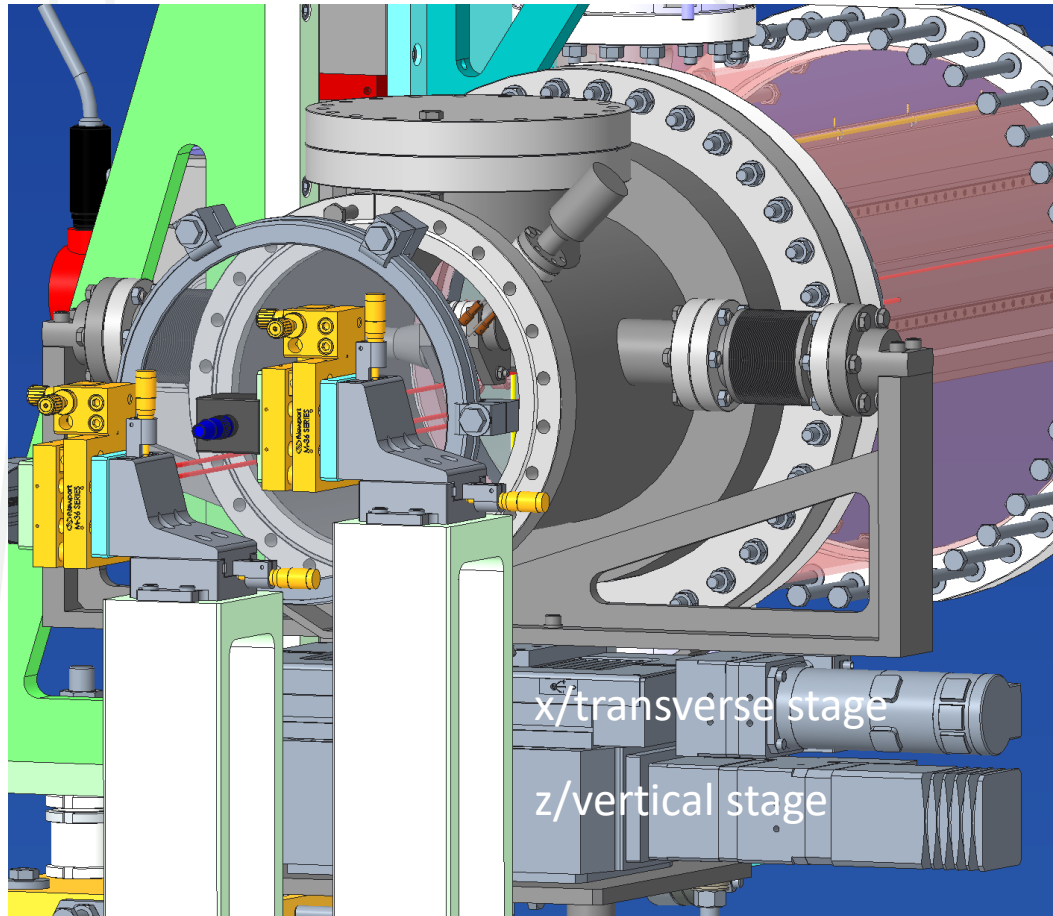

- Adapted from a system built by Danfysik
- XZ motion translated through bellows
- Additional ST5 drives to increase speed to maximum of motors
  - X motion 20 mm/s
  - Z motion 1 mm/s
- Use Hilbert transform of  $I_z$  to obtain  $I_x$
- 0.1 mm TiAlV wire
- Vertically positioned using capacitance measurements
- Keithley 2182A nanovolt meter

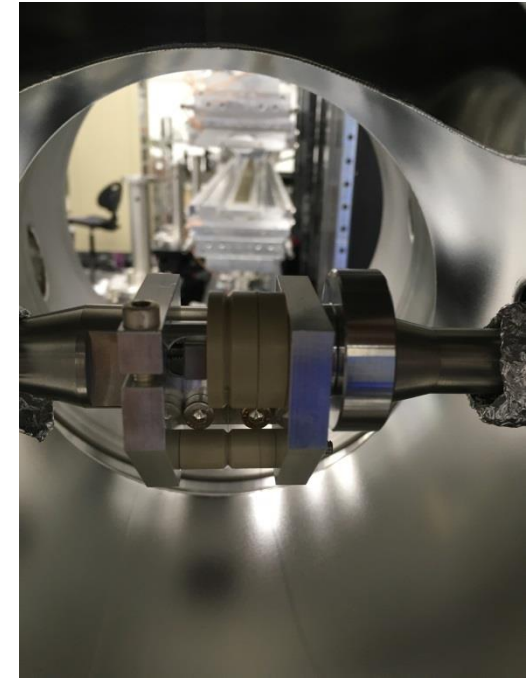

# In-vacuum cold bench: Stretched wire

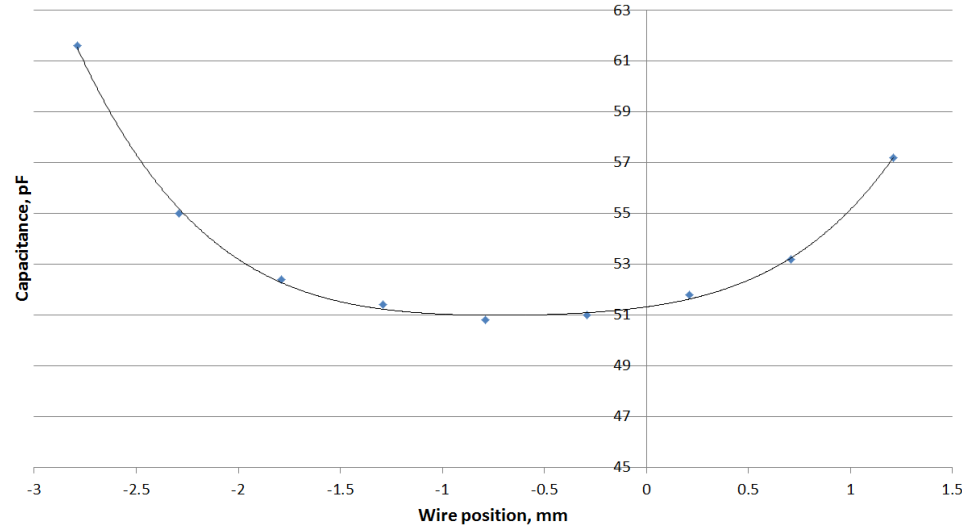

Upper girder

Wire ●

Lower girder

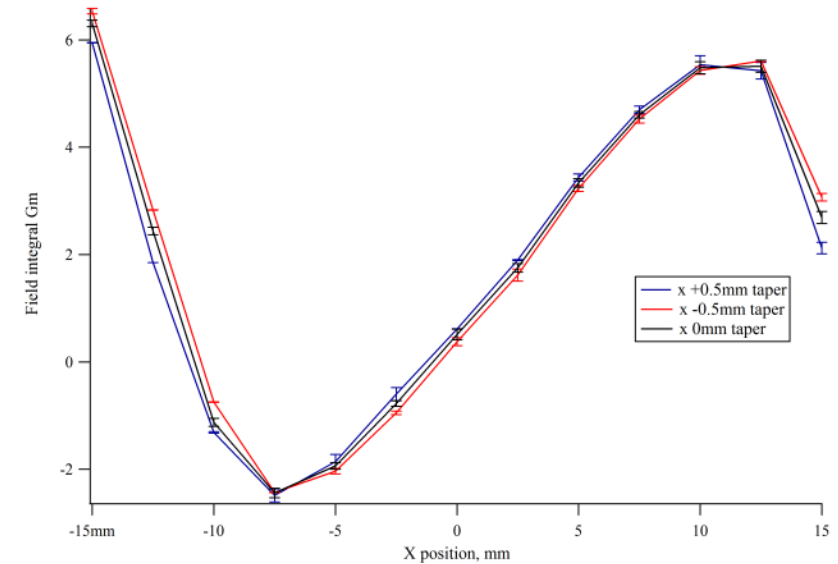

## Vertical alignment:

- Treat the girders and wire as two parallel plates & wire added in series
- Measured capacitance using a Wayne Kerr inductance analyser
- Move each end independently to get the wire centred at each end – will be at a capacitance minimum

## Horizontal alignment:

- Set by eye using foil tensioner blocks as a guide
- Minimal effects from horizontal taper up to  $\pm 0.5$  mm

# Hall probe sag adjustment

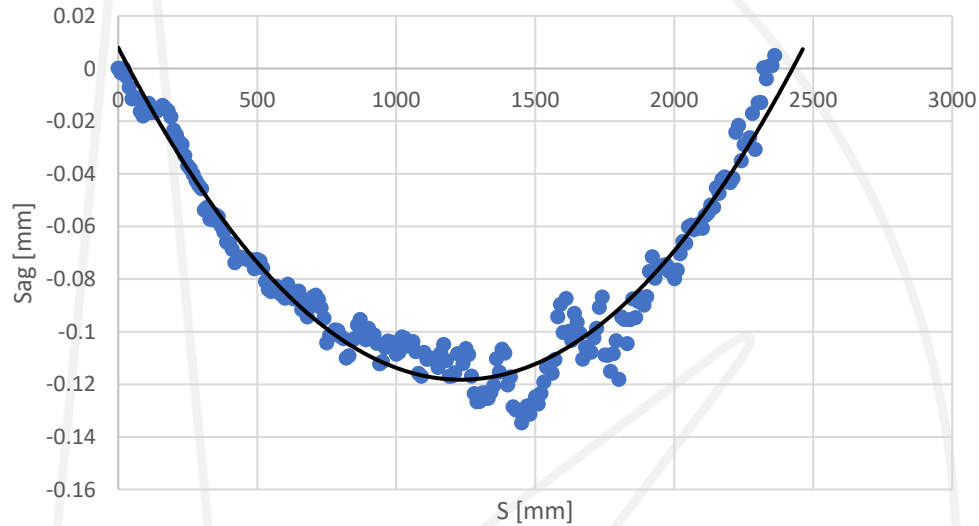

- Sag measured using Leica laser tracker
- Beam mechanically adjusted so ends are level
- Compensation table implemented in Geobrick motion controller

Peak field difference between sag-compensated and not compensated:

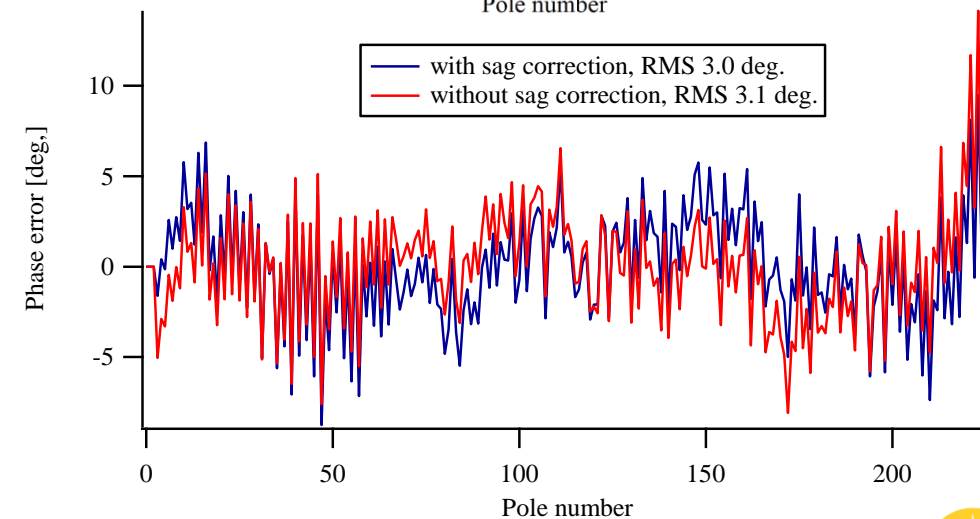
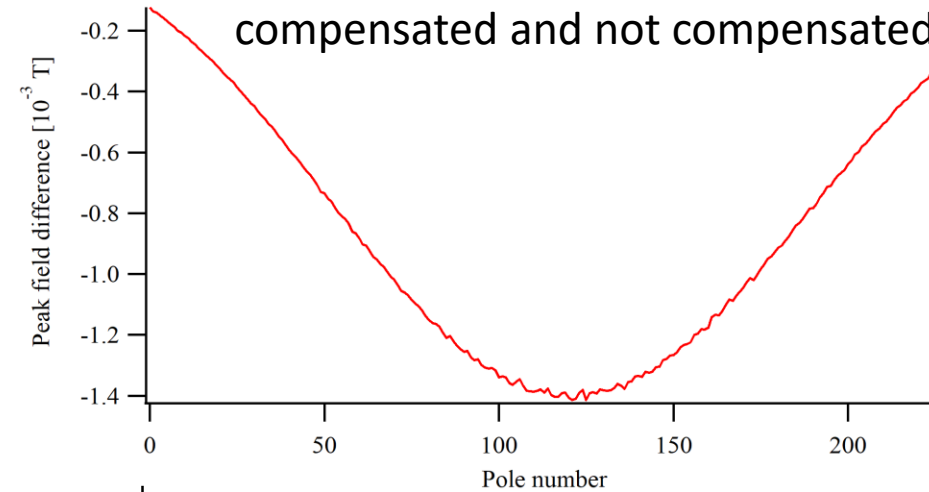

30/09/2022

# Hall probe temperature adjustment



Arepoc probe calibrated to

4.2 K

Senis probe calibrated at

23°C

Peltier cooler + compressed  
gas through Al block to cool  
probe.

1.44 T magnet.

V/T known at 23°C.

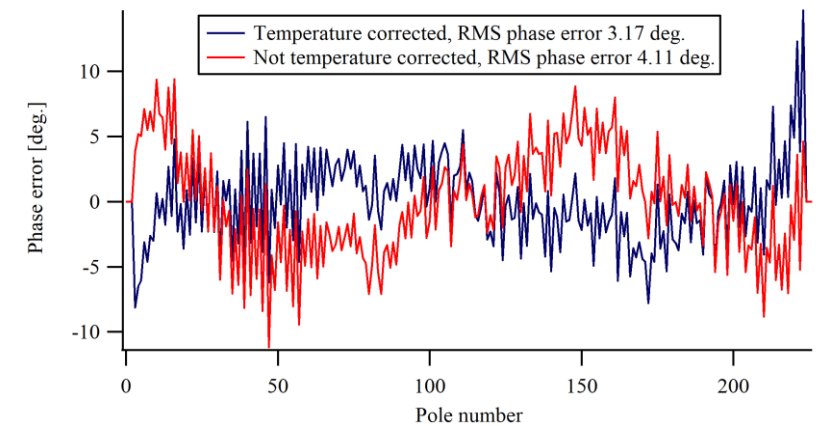
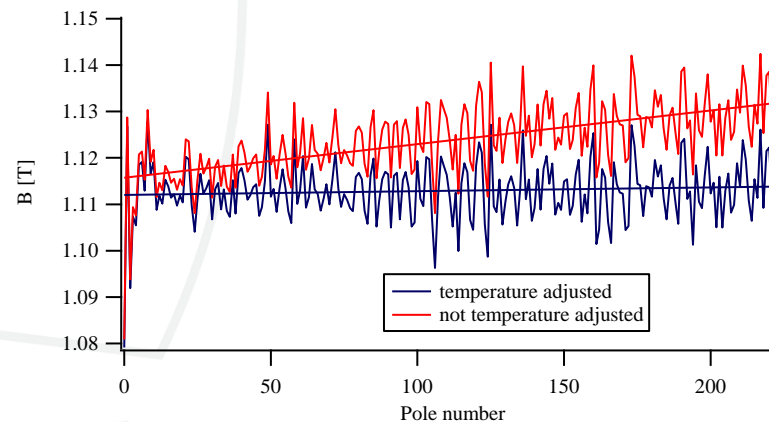
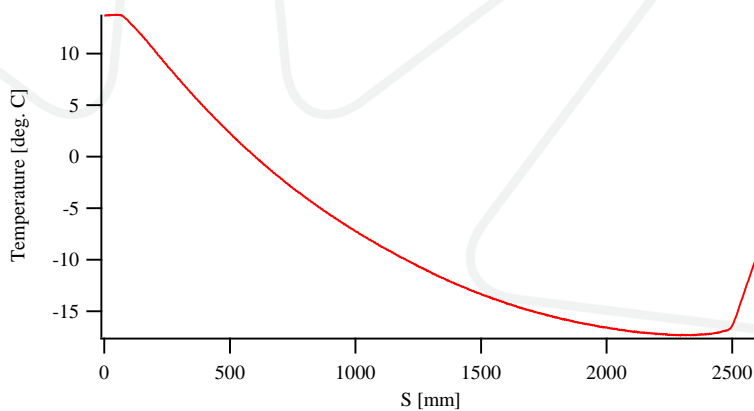
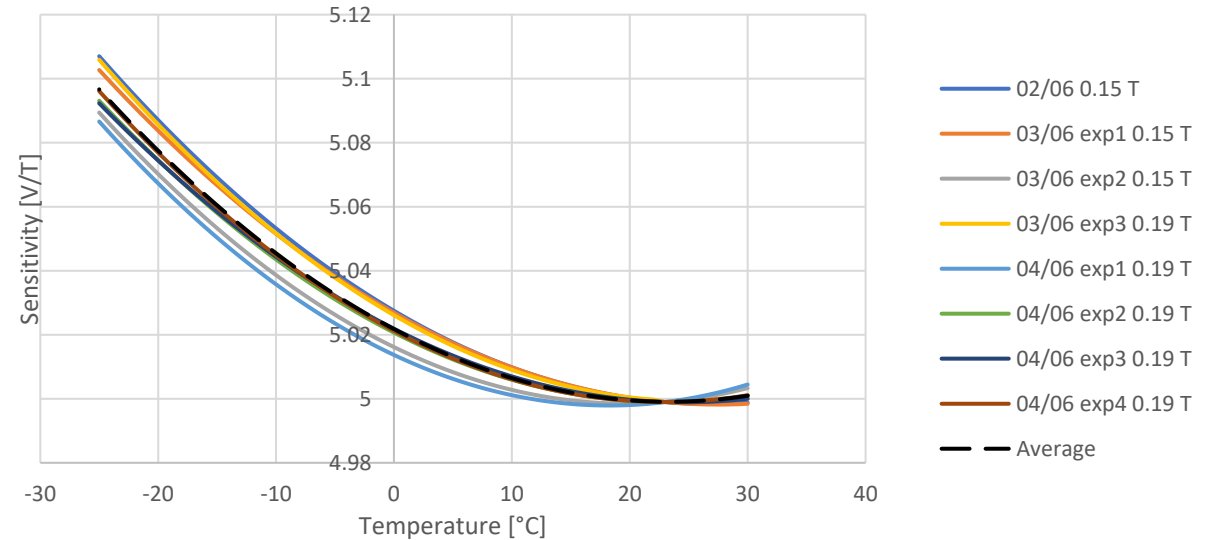

# CPMU measurements

- All 4 installed CPMUs were measured with version 2 of the cold bench
- Cold bench Hall probe: Arepoc for CPMUs 1-3, Senis for CPMU-4
- Main bench Hall probe changed Bell → ADC → Senis, sometimes during one CPMU measurement campaign due to instabilities and unreliability
- New relative pole height gauge for in-situ pole shimming

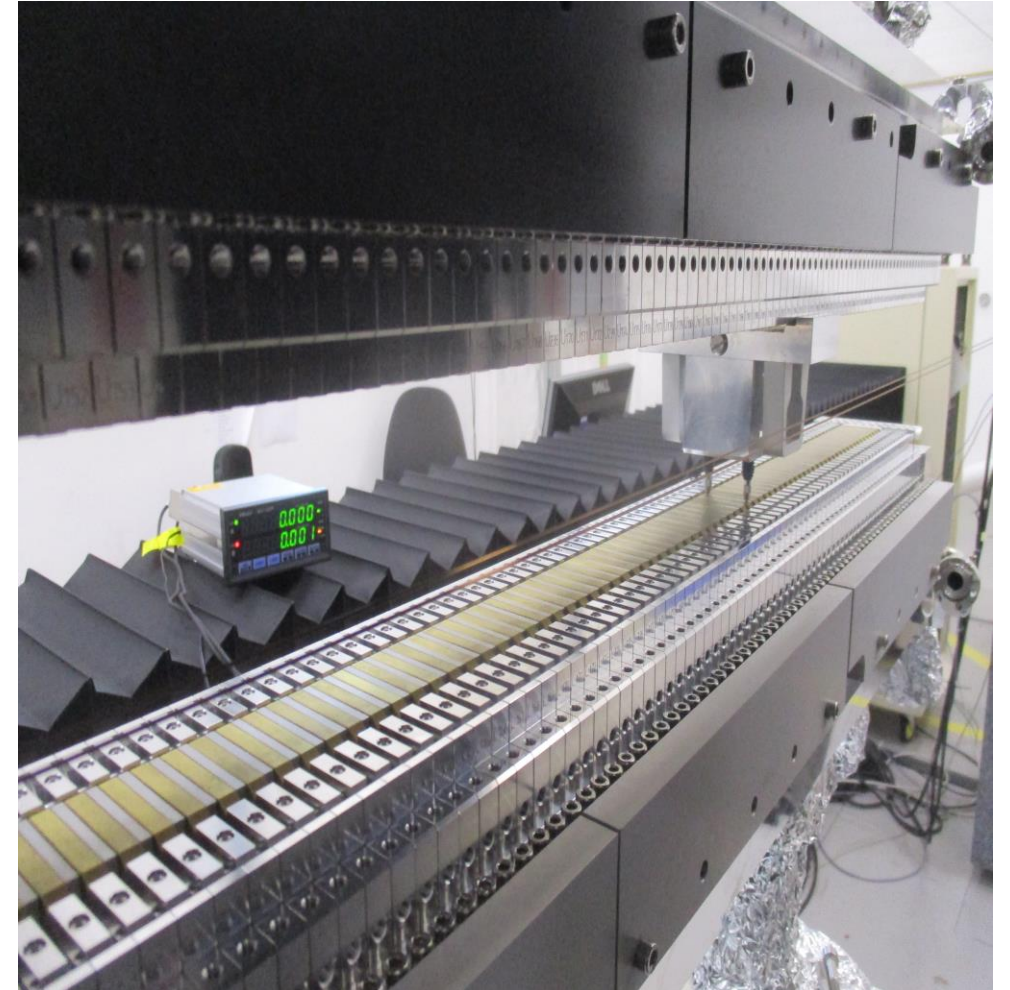

# Results: CPMU-4 at room temperature

Measured at 5 mm gap

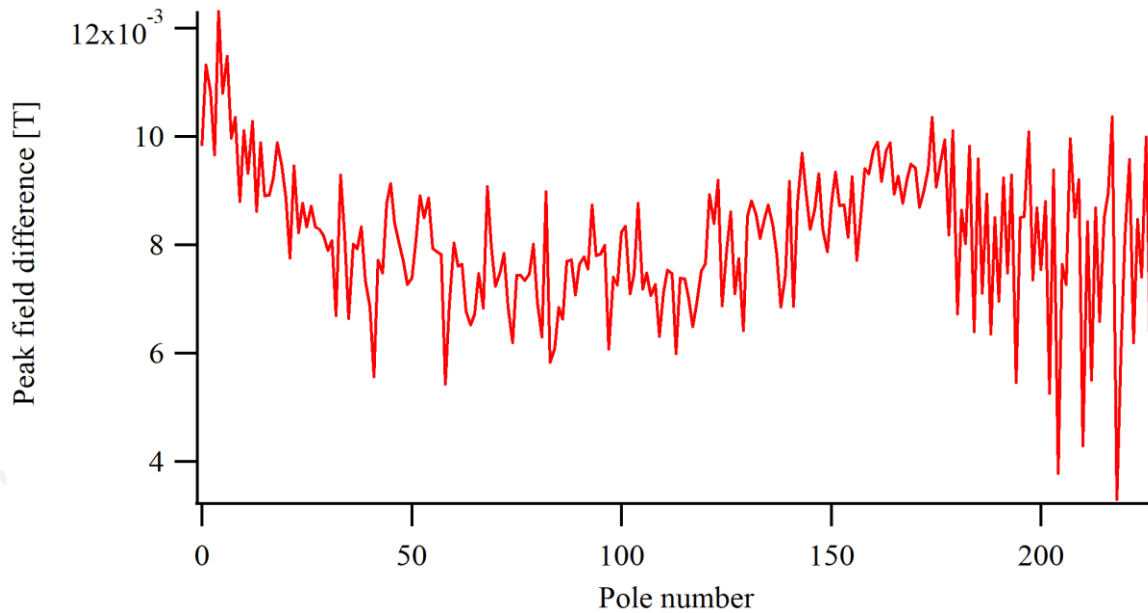

Higher peak field measured by cold bench probe

- Girders disturbed during vacuum build
- Differences between probes – under investigation

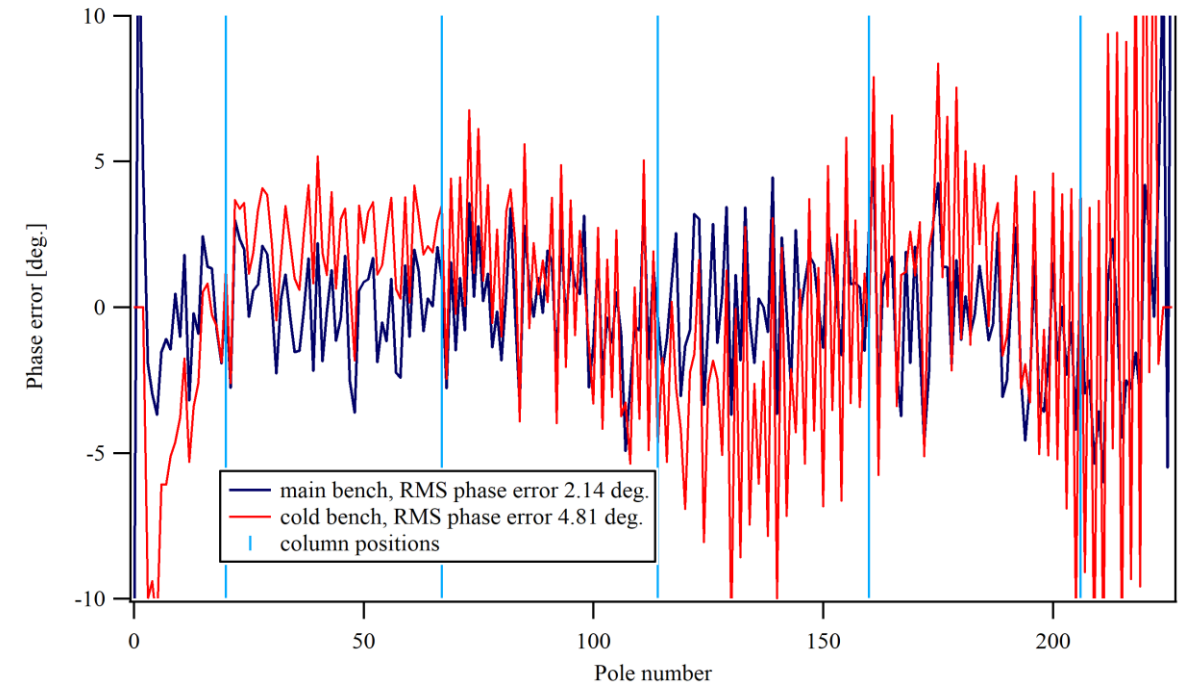

Phase error worse due to removing and remounting magnet girders on structure for vacuum build

# Results: CPMU-4 cold measurements

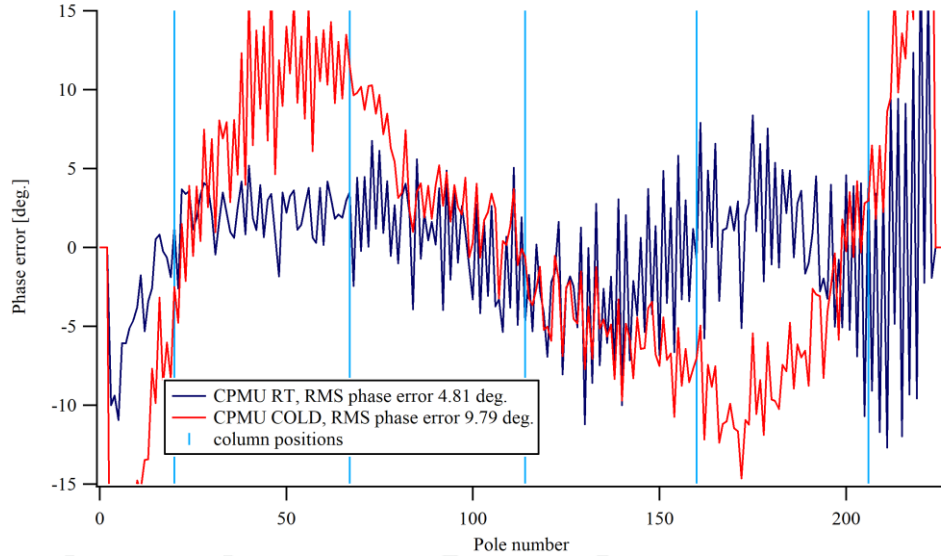

Measured at 5 mm gap; gap when cold measured by telescope with parallel plate  
On initial cool down the RMS phase error increased by 5°

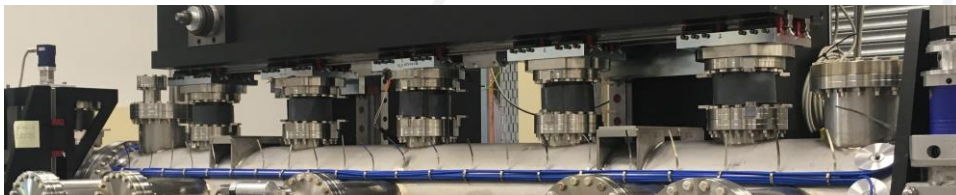

30/09/2022



Column shimming predictions made using shim signatures and Igor Pro script

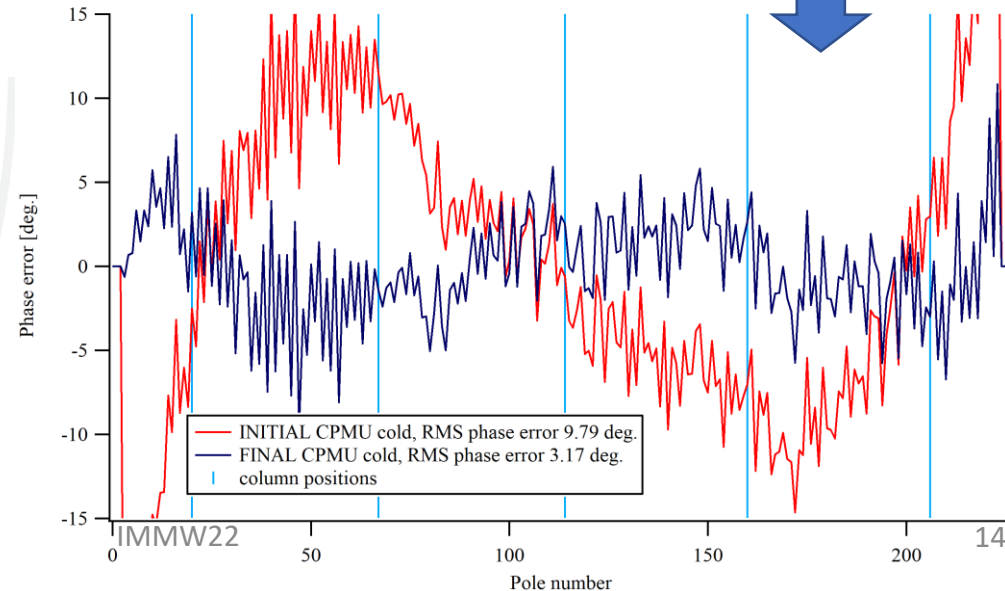
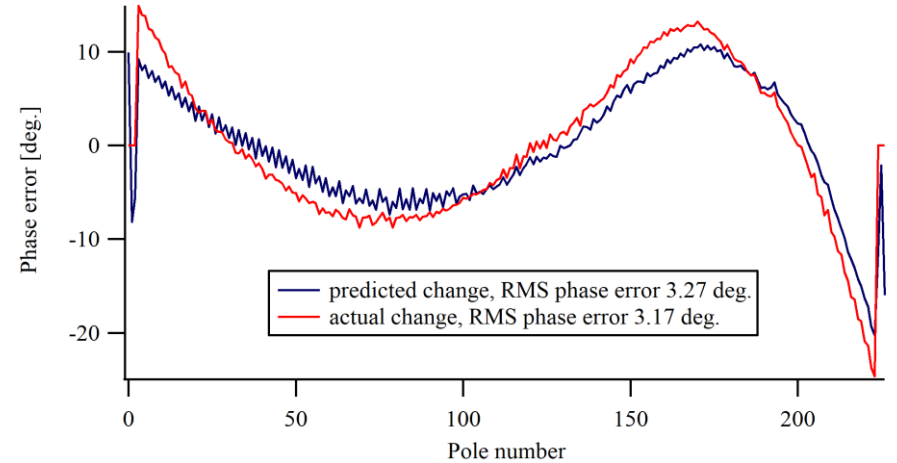

After 3 days (6 iterations) of column shimming the RMS phase error is close to the target of 3°

# CPMU-4 installation

Beam-based alignment:

1. Offset. 50  $\mu\text{m}$  found
2. Taper. None needed
3. Tilt. None needed

Total flux from ideal 17.6 mm CPMU and beamline measurements of the CPMU and previous U23.  
Up to 5x gain in flux

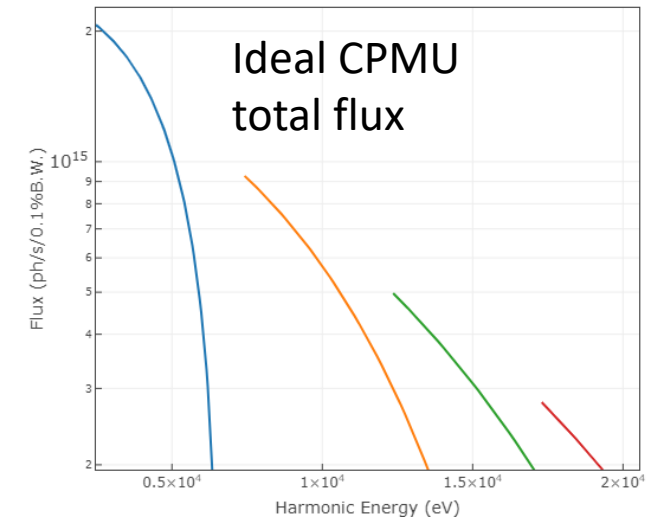

1

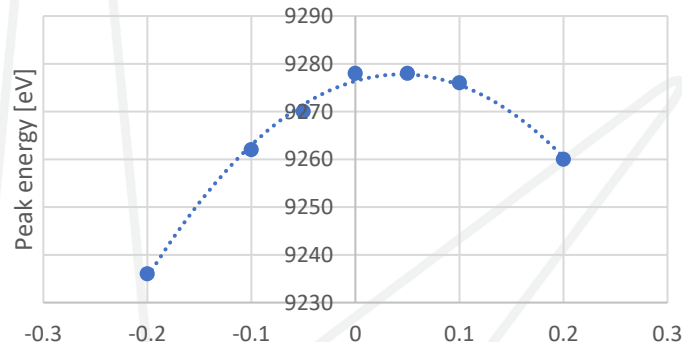

2

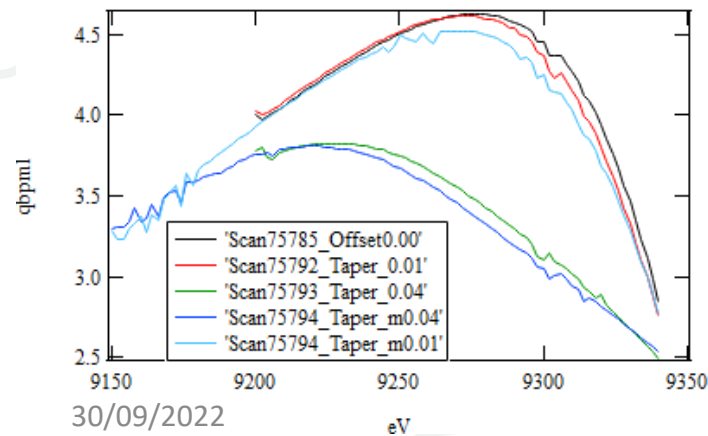

30/09/2022

3

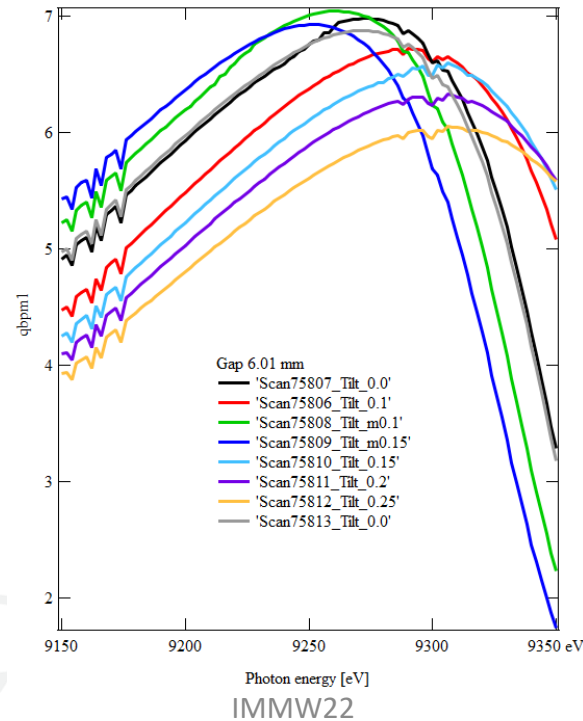

IMMW22

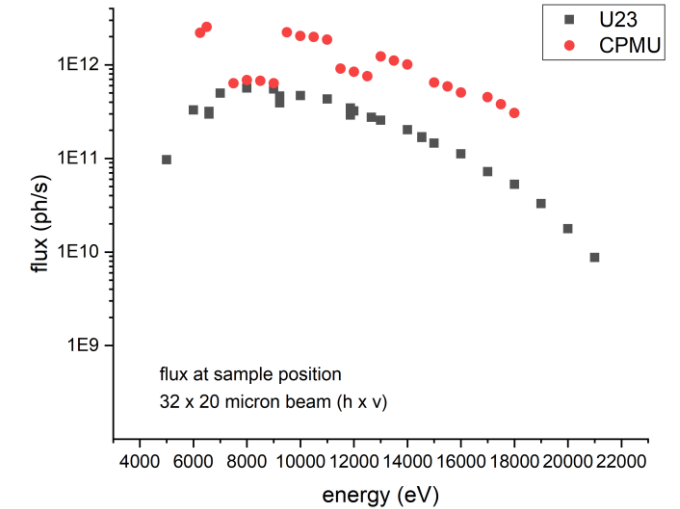

Can bridge the gap between 7 keV and 9 keV with smaller ID gaps

# Diamond-II

Parameter	Diamond I	Diamond-II
Emittance (nm.rad)	3.14	0.125
Electron energy (GeV)	3.0	3.5
Beam Current (mA)	300	300

Ten IDs (red) to be changed during the dark period plus two IDs (purple) for flagship beamlines.

Additional resources already in place:

- 2 ID physicists
- 2 mechanical technicians
- New 3 m out-of-vacuum measurement bench (Hall probe & flipping coil)

Beamline	ID	Period (mm)	N	L (m)	Gap (mm)	B (T)	K	Diamond-II energy range (keV)	Ptot (kW)
I11	CPMU-1	17.6	113	2	4	1.4	2.3	9 – 35	9.06
I04	CPMU-4	17.6	113	2	4	1.36	2.24	5 – 30	8.55
K02 (VMXm)	CPMU-5	17.6	113	2	4	1.4	2.3	5 – 30	9.06
K04 (XChem)	HPMU-1	19.7	78.5	1.6	4	1.31	2.4	10 – 25	8.01
I05	APPLE K-1	200	25	5	21	0.57	10.7	0.010 – 0.24	3.65
I02 (VMXi)	CPMU-5*	17.6	113	2	4	1.4	2.2	5-30	8.6
K02 (VMXm)	CPMU-6	17.6	85	1.5	4	1.4	2.3	5 – 30	6.8
I09.1	HPMU-3	23	87	2	6.4	0.97	2.1	2.1 – 18	4.4
K21	HPMU-4	18.7	80	1.5	4	1.17	2.1	6 – 14.5	4.8
K16	HPMU-5	18.7	80	1.5	4	1.17	2.1	6 – 45	4.8
I06	APPLE II-1	56	33	2	19.5	0.73	3.82	0.25 - 2.1	2.29
	EMPHU	65	24	1.75	12.5	0.265	1.61	0.5 - 1.7	0.51
I08	APPLE II-2	56	70	3.97	19.5	0.732	3.82	0.25 – 4.2	4.8
I10	APPLE II-3	56	70	3.97	23	0.6	3.1	0.35 – 1.6	3.2
K07(B07-2)	APPLE II-4	64	28	1.94	18	0.87	5.2	0.125 – 4.0	3.38
K18	3PW	–	1	2	12	1.4		2 – 30	0.4
I17 CSXID	APPLE II-6	52	94	5	16.5	0.82	3.99	0.25-3.0	7.66
K14 SWIFT	MPW	116	6	0.7	15	1.3	14.1	4 – 35	1.7

# New out-of-vac bench

- Smaller version of the main bench for measuring 2 m long devices
- Designed, built, and commissioned in-house
- Hall s/longitudinal motion uses rack & pinion track rather than an electromagnetic track
- Measured CPMU-1 on main bench then new bench for commissioning

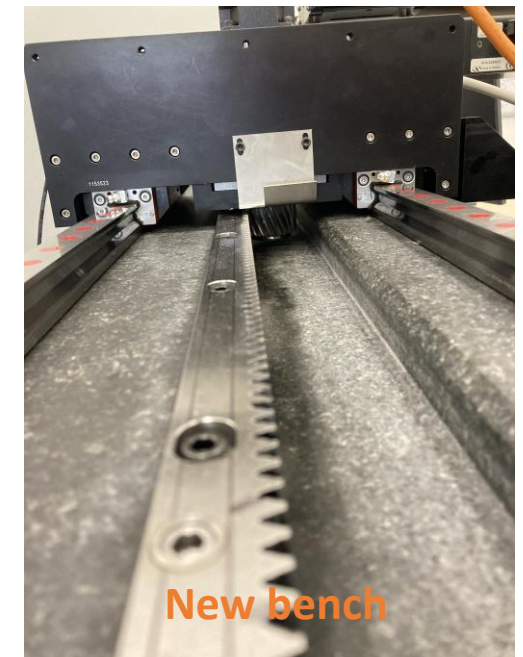

# New out-of-vac bench

Survey measurement of Hall probe bench rails

- Transverse (x) varies by  $60 \mu\text{m} / 3 \text{ m}$  on average
- Height (z) varies by  $20 \mu\text{m} / 3 \text{ m}$  on average

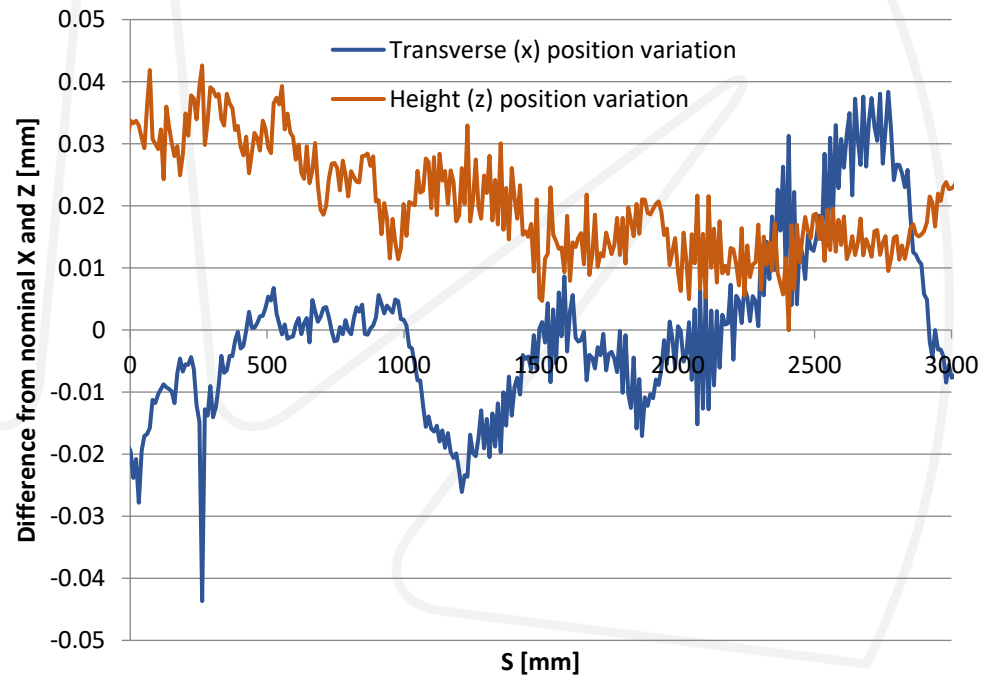

Comparison of new bench to main bench

- Peak field average offset of 7.4 mT
- 1-2 mT difference after removing offset = same as scan repeatability

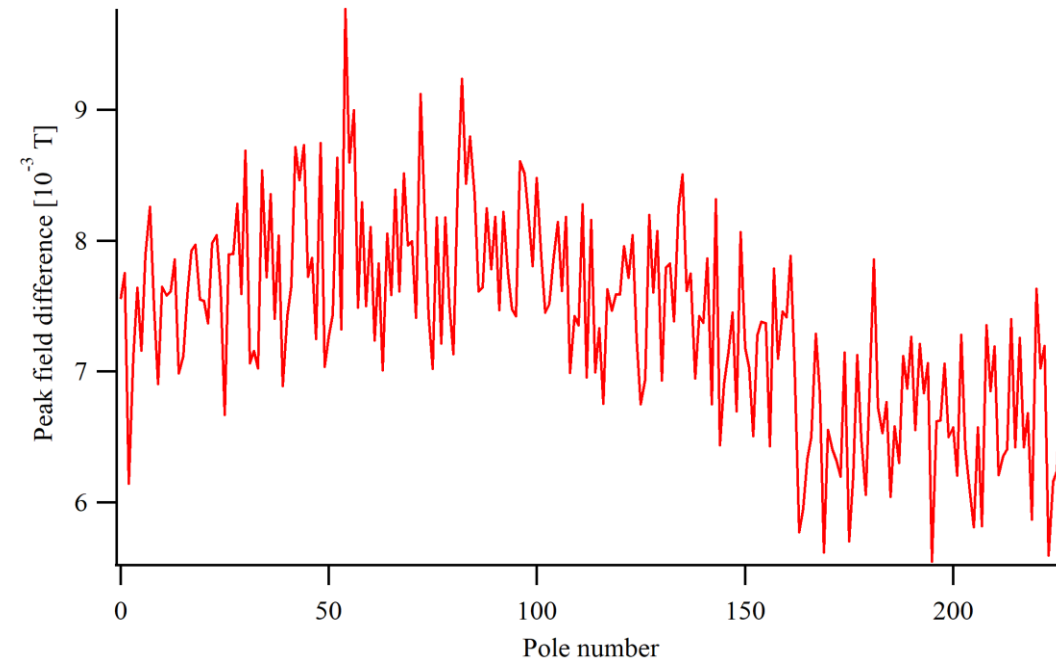

# Future plans

- Upgrade cold bench
  - Drive Hall vertical motion with lead screws rather than cams for larger range to make set-up easier. Currently limited to 1 mm
  - Faster vertical motion for the stretched wire so we do not have to use the Hilbert transform. Currently limited to 1 mm/s
  - Tilt and roll stages for the Hall probe for better alignment
- New flipping coil or stretched wire bench for APPLE KNOT magnet/module measurement to reduce shimming

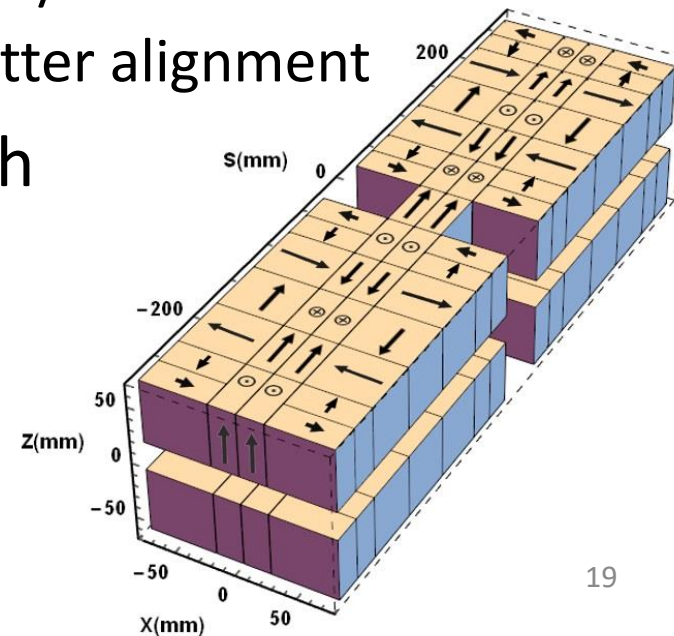

A. Ramezani  
Moghaddam,  
accepted for  
publication in  
RSI

# Thank you

- Steve Milward
- Geeta Sharma
- Ali Ramezani Moghaddam
- Sumit Tripathi
- Joe Williams
- Angela George
- Marco Marziani
- Steve Hale
- Chris Green
- Martin Reeves
- Ronaldo Mercado
- Survey group
- Motion control group

IMMW22



In Memory of  
Joe Williams

