

WMM Testbench for MCBXF Series Production

Ó. Durán¹, L. González¹, C. Martins¹, F. Toral¹

L. Fiscarelli², J.C. Pérez², P. Rogacki²

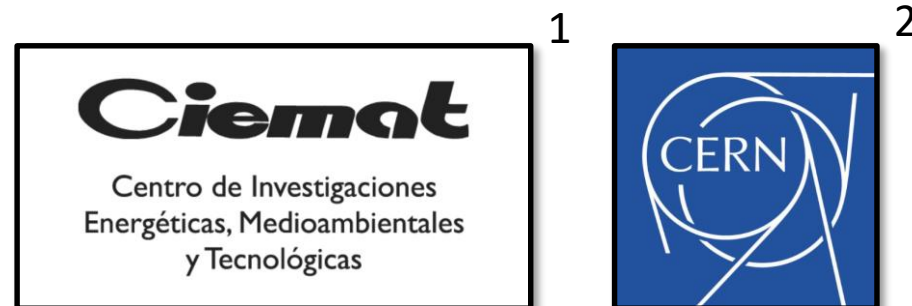

- MCBXF
- MCBXF at Elytt Premises
- The WMM Testbench
- The operation protocol
- Controls
- Data analysis and reference systems
- Summary

The layout up to Q4:

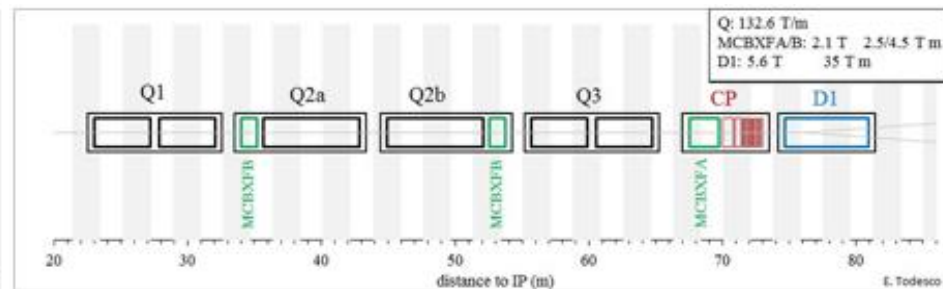
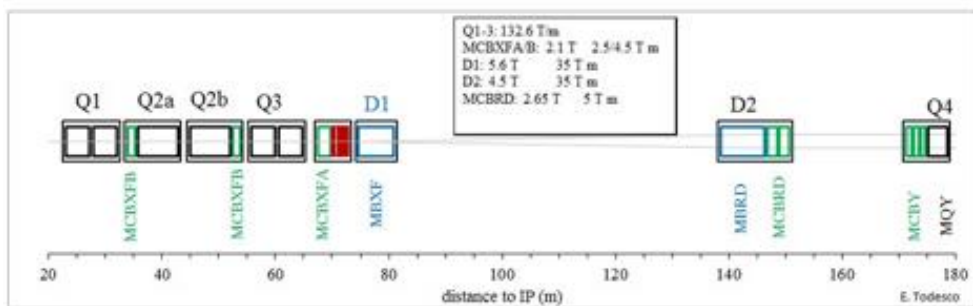

Magnification of the area around correctors:

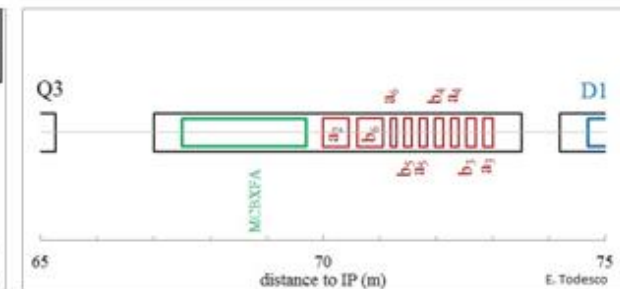

The layout up to Q4:

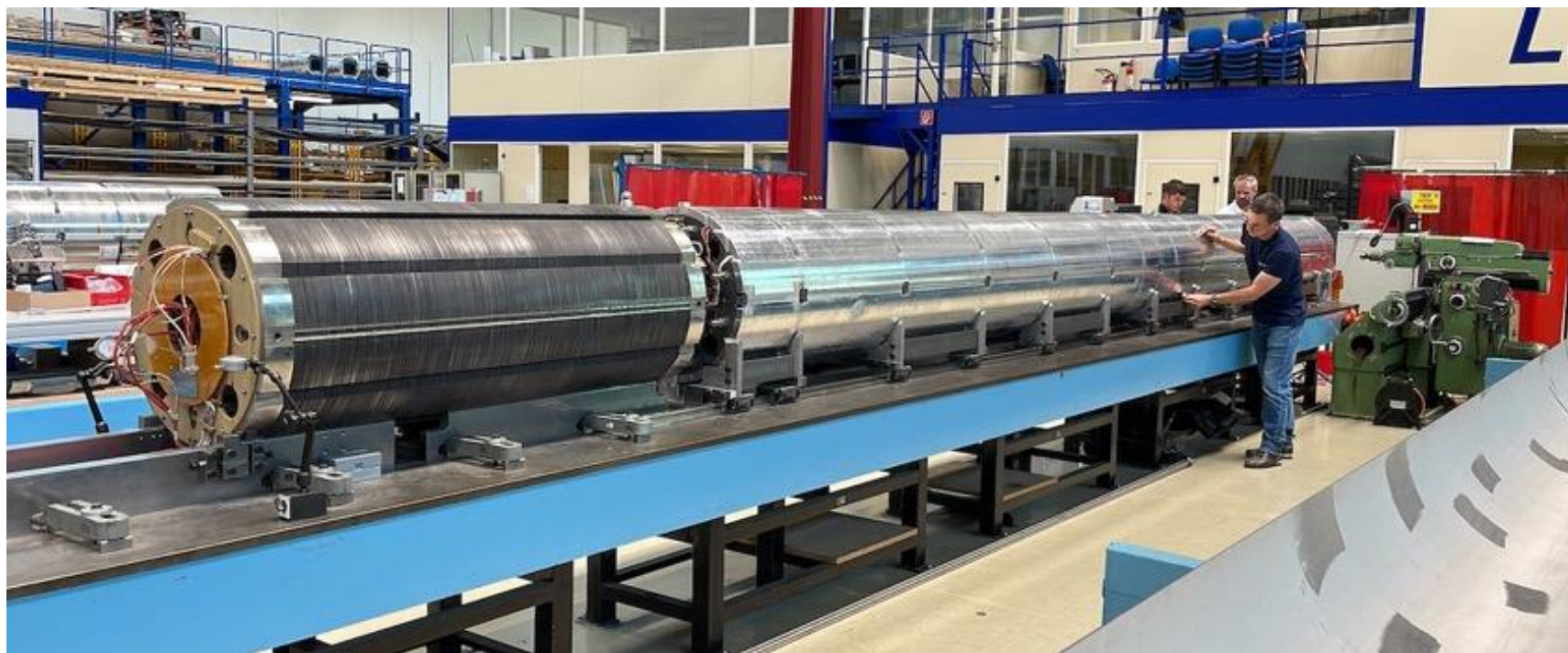

Courtesy J. C. Pérez

Horizontal Field	2.1 T
Vertical Field	2.1 T
Integrated field	2.5 Tm (MCBXFB)
Nominal current (Inner)	1400 A
Nominal Current (Outer)	1700 A
Aperture	150 mm
Radiation resistance	35 MGy
Working Temperature	1.9 K
Torque	1.2E5Nm/m
Field Quality	
b3 / a3	< 10 units
b5 / a5	< 7 units
Higher order multipoles	< 5 units

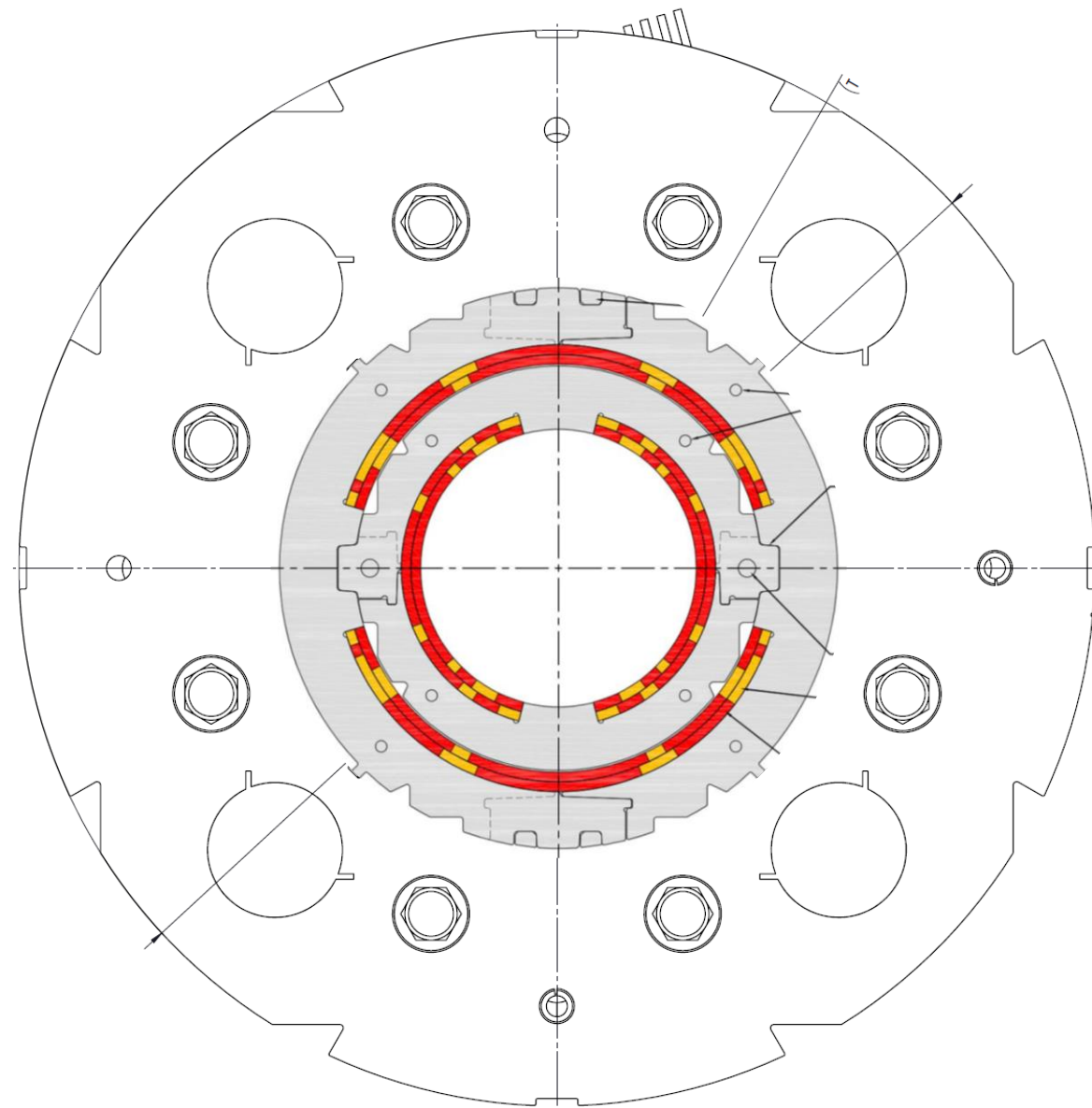

MCBXFB/A

Designed at CIEMAT, Madrid, Spain

First prototypes: - Manufactured at CIEMAT
- Assembled at CERN, blg 927
- Tested:

WMM at CERN, blg 927
Cold Test at CERN SM18

Series production: - Manufactured at Elytt, Álava, Spain
- Assembled at Elytt
- Tested:

WMM at Elytt
Cold Test at CERN SM18



Hall with two clean areas: coils (left) and magnets (right)



Magnet assembly area

1 measurement

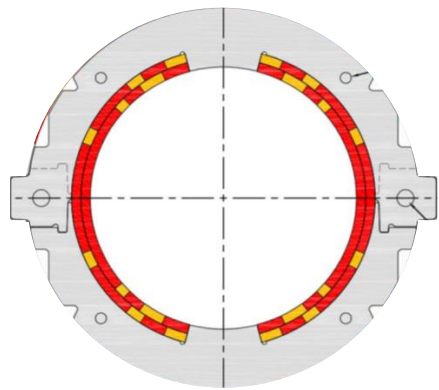

Inner dipole collaring

2 measurements

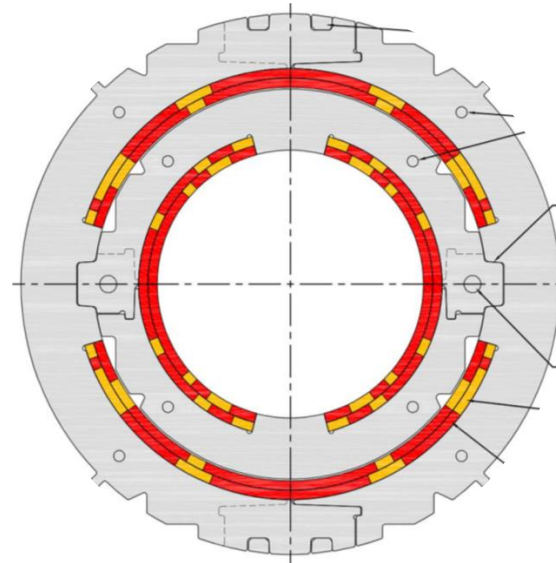

Outer dipole collaring

2 measurements

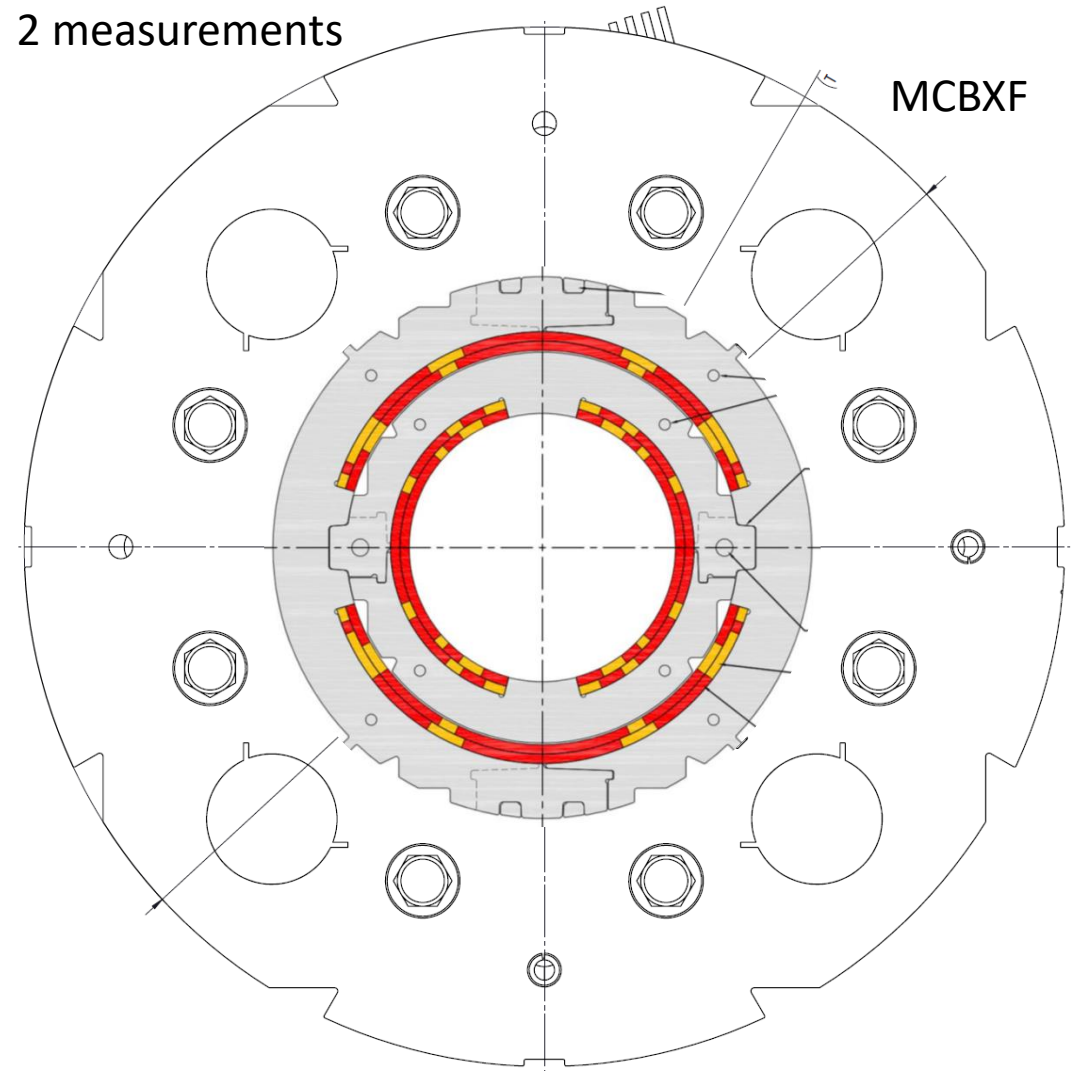

Complete magnet assembly with iron

- Warm magnetic measurements testbench manufactured at CERN in collaboration with CIEMAT
- Testbench installed at Elytt premises – Challenges:
 - Robustness – Needs to be able to survive in industry (a hostile environment for metrology)
 - Straightforward to be operated at Industry:
 - Software's GUI
 - Operation protocol

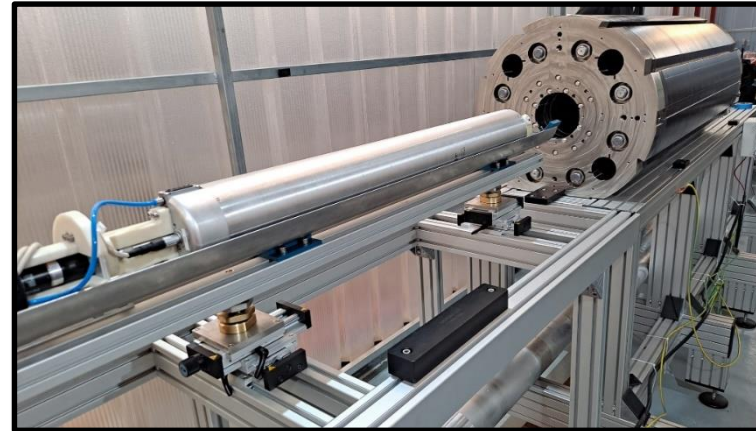

MCBXF WMM at Elytt premises

- Warm magnetic measurements testbench manufactured at CERN in collaboration with CIEMAT
- Testbench installed at Elytt premises – Challenges:
 - Robustness – Needs to be able to survive in industry (a hostile environment for metrology)
 - Straightforward to be operated at Industry:
 - Software's GUI
 - Operation protocol
- CIEMAT trains Elytt technicians and engineers to operate the bench
- Each measurement campaign always supported by CIEMAT
- Data is post processed by CIEMAT

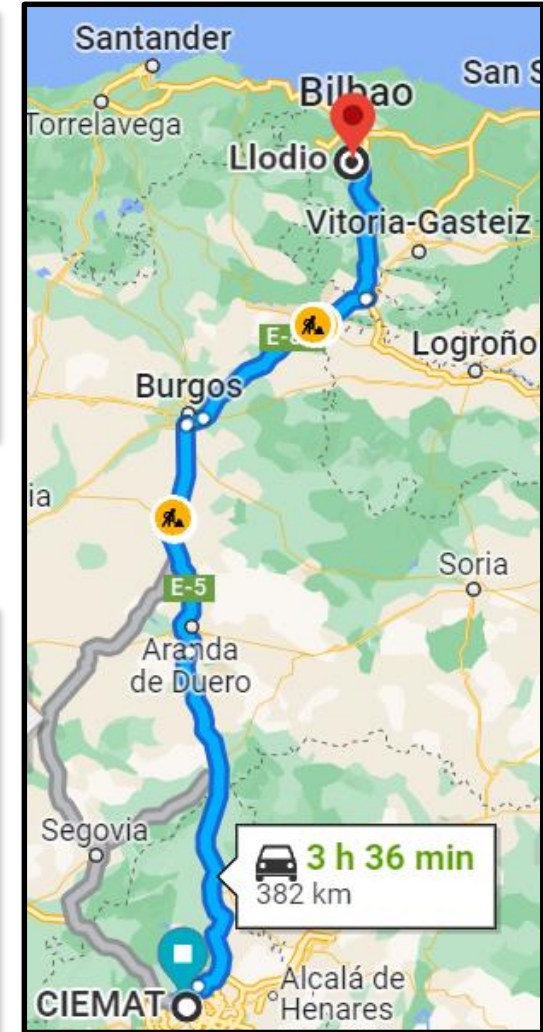
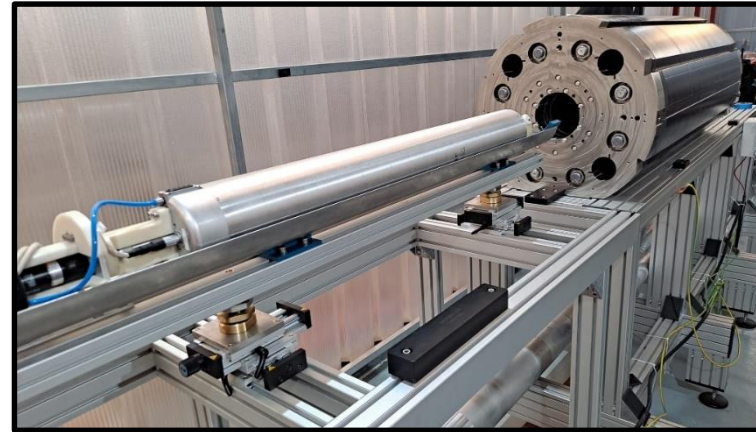

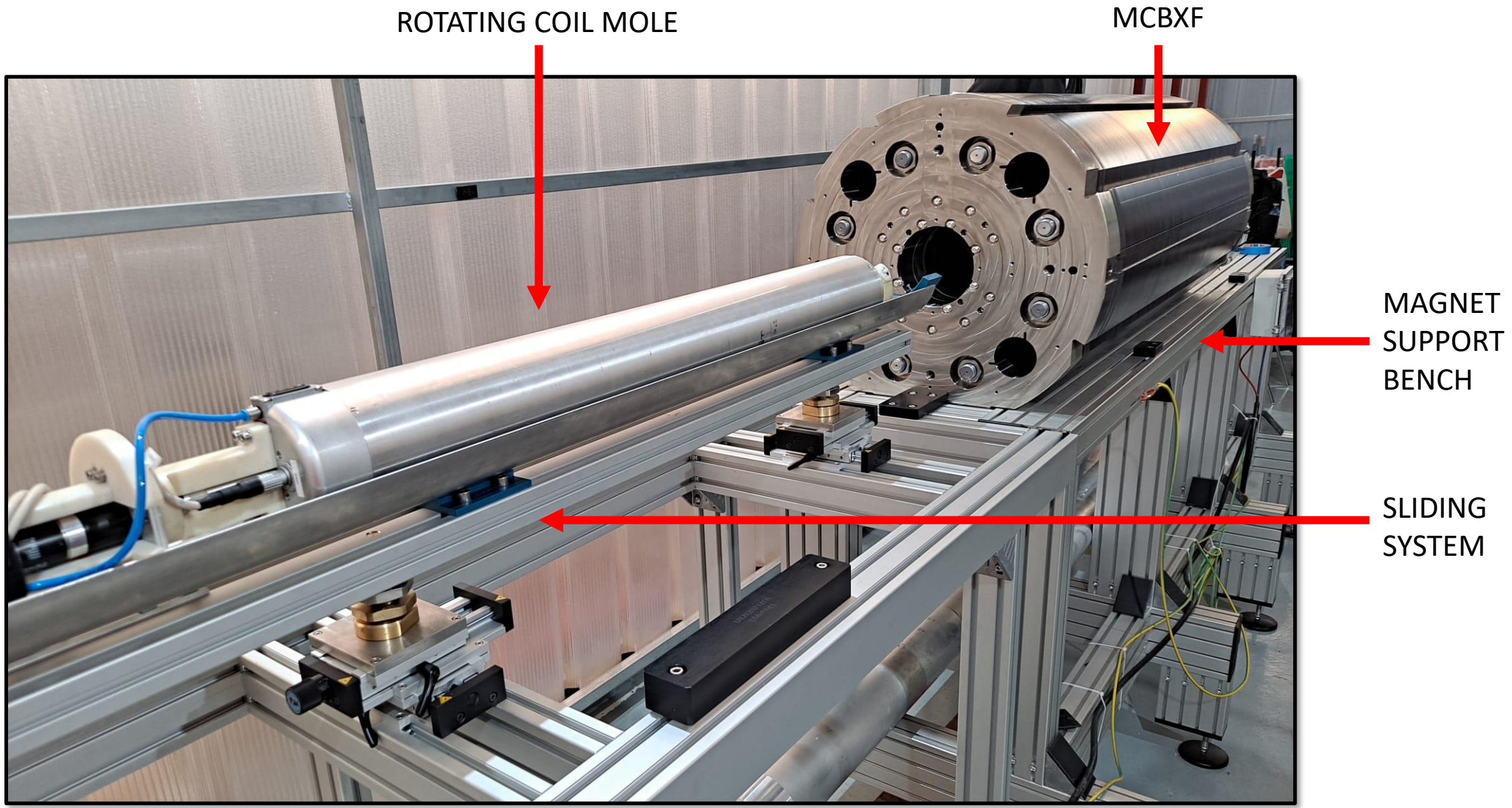

MCBXF WMM at Elytt premises – The TestBench

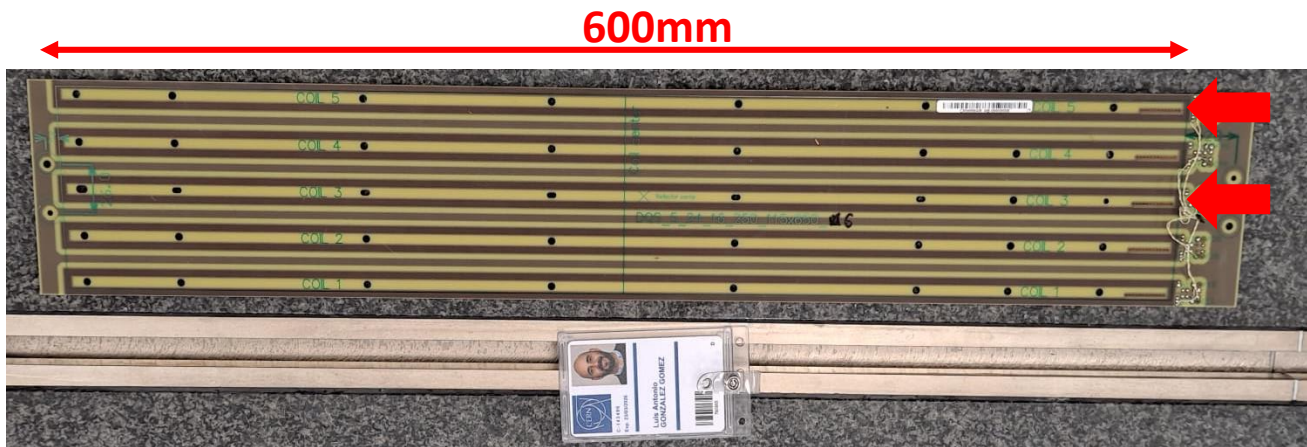
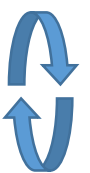
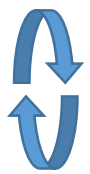

Main Signal
Rref 50 mm
Compensation coil



Motor
+
Electrical
connections

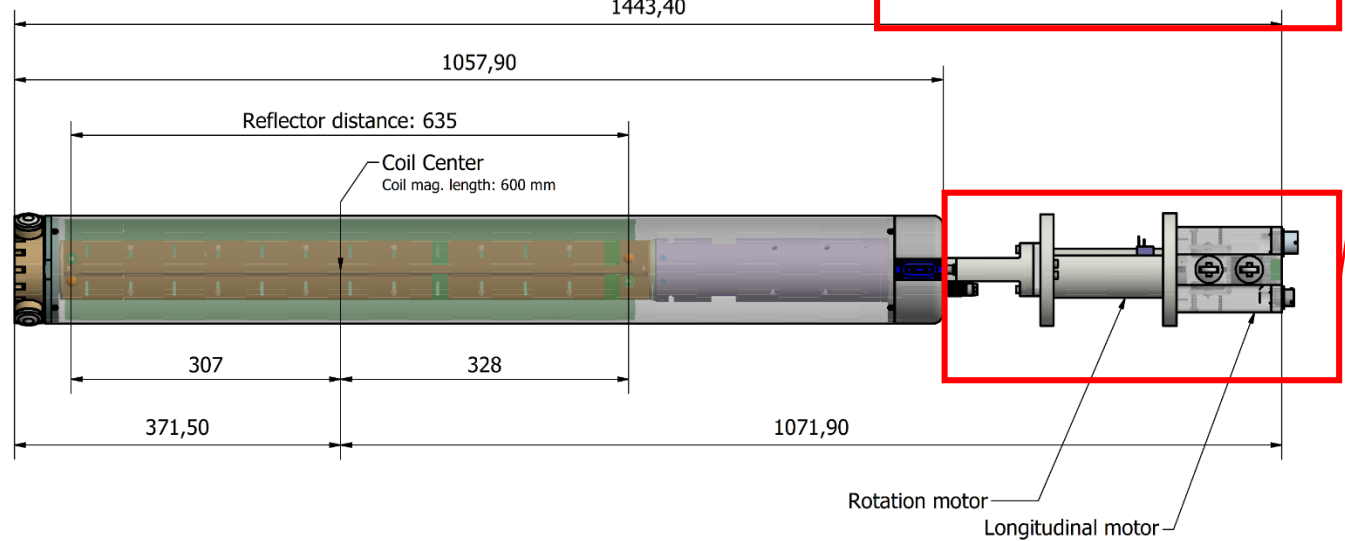

Rotating coils printed on PCB board

- Encapsulated
- Easy manufacturing
- High mechanical accuracy
- High magnetometric resolution

Piotr Rogacki Ph.D. Thesis

“A contribution to the development and characterization of rotating-coil magnetometers”

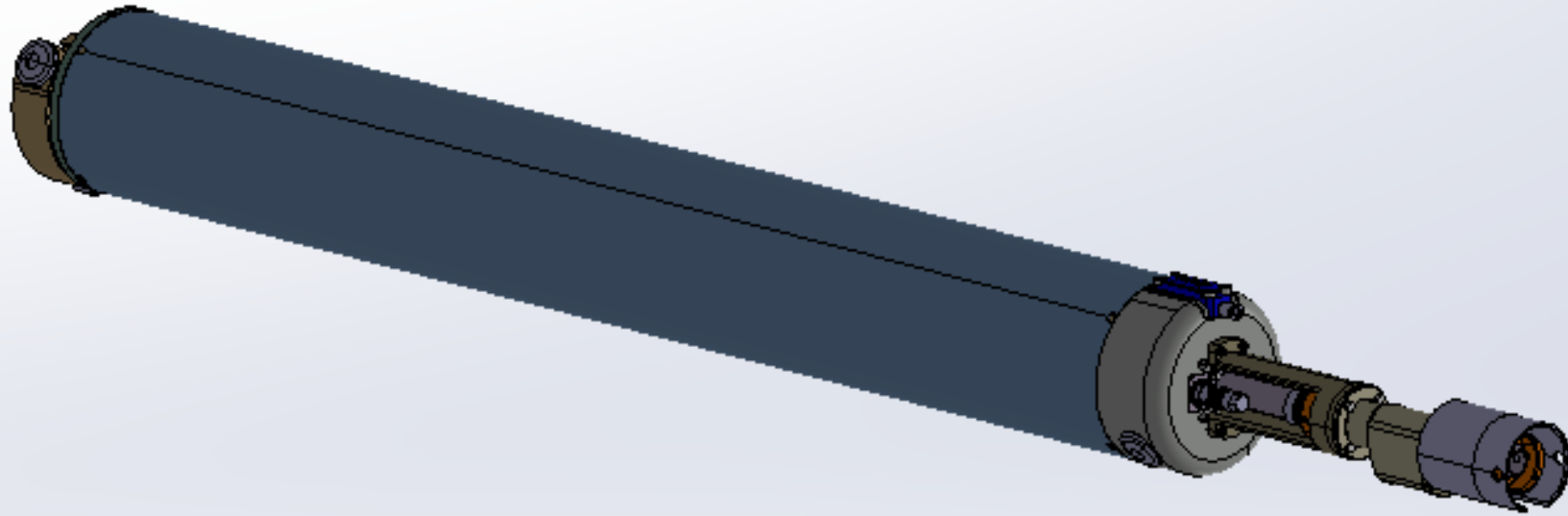

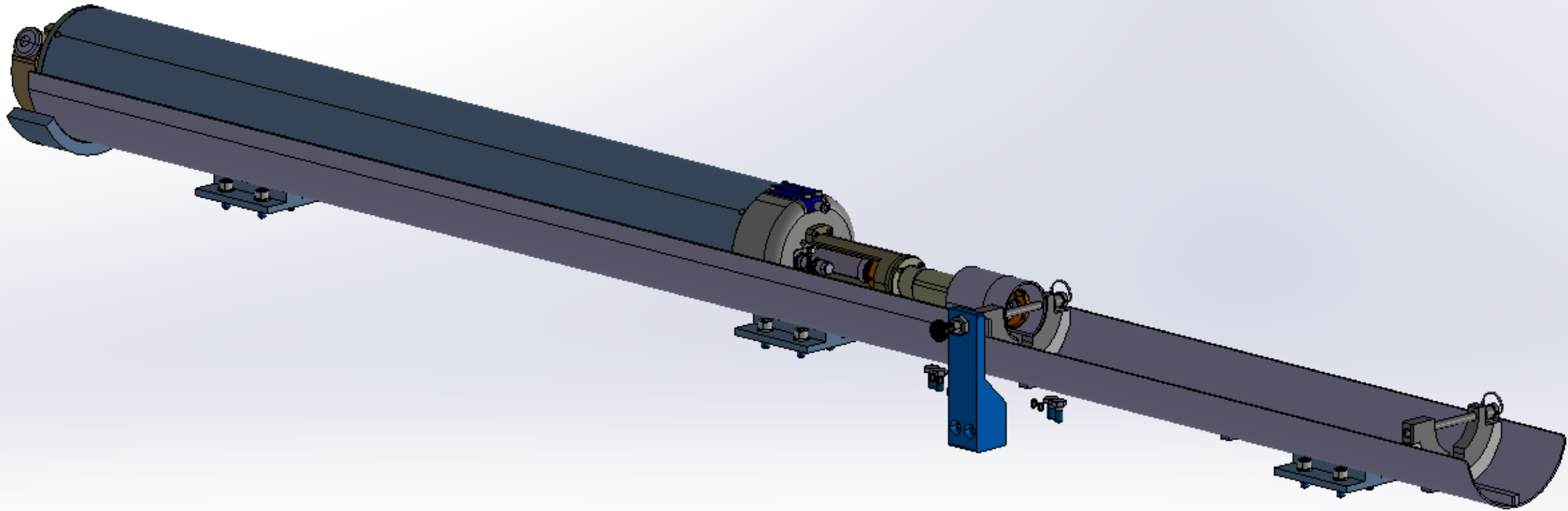

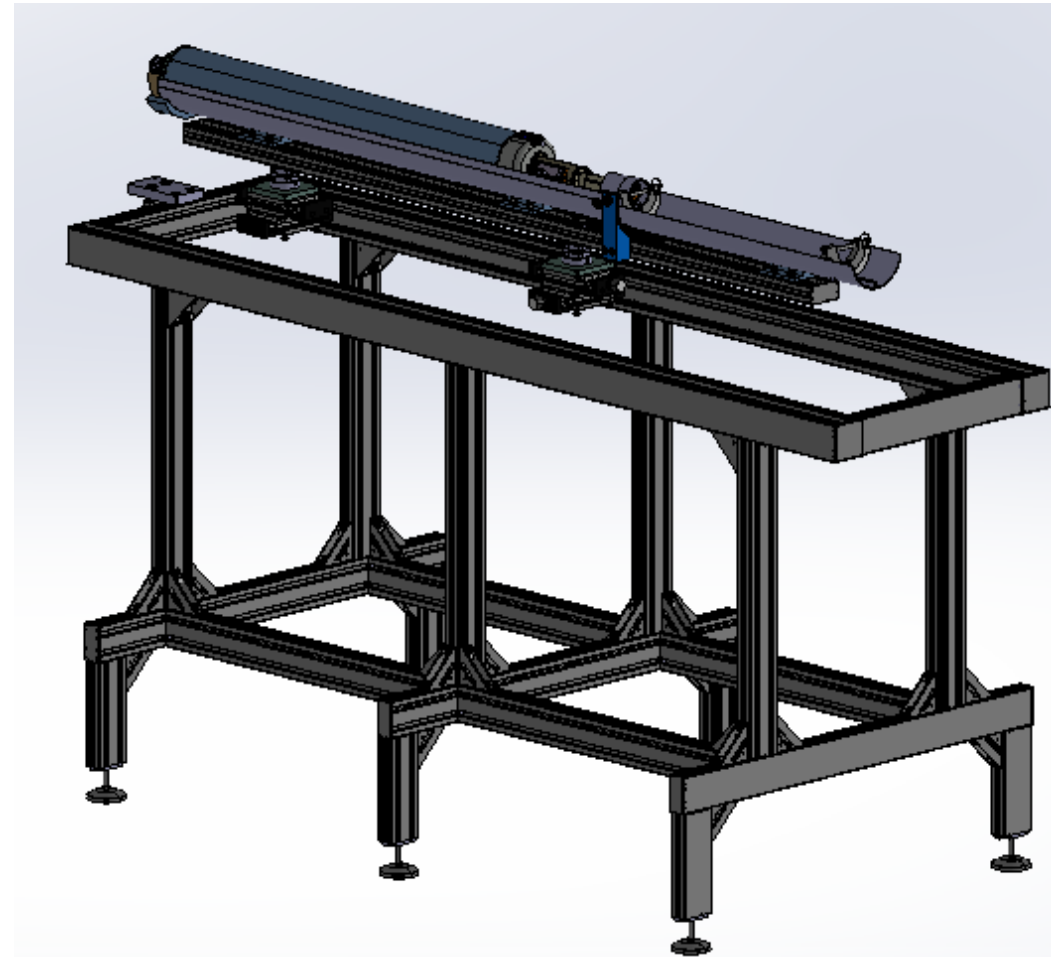

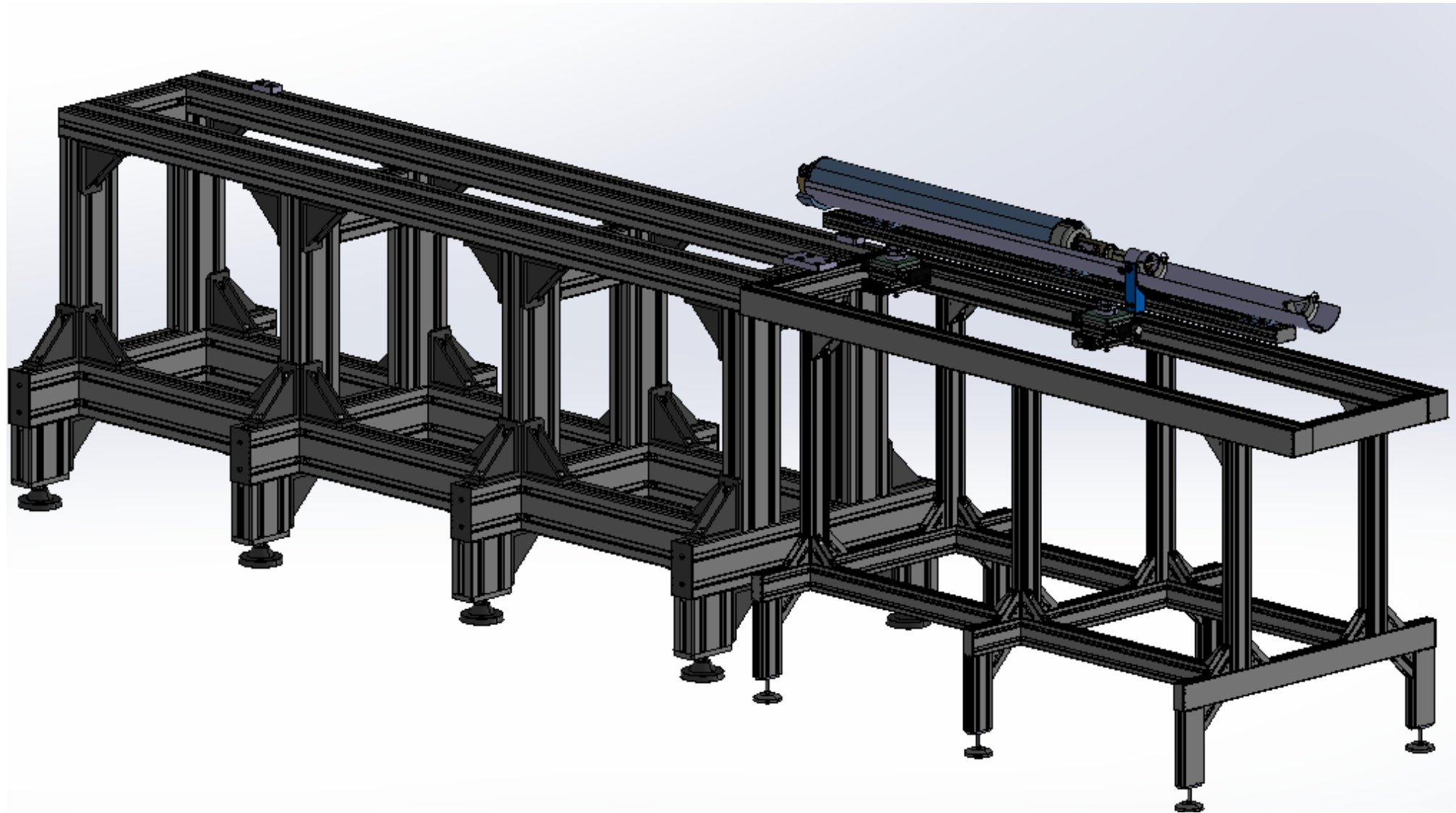

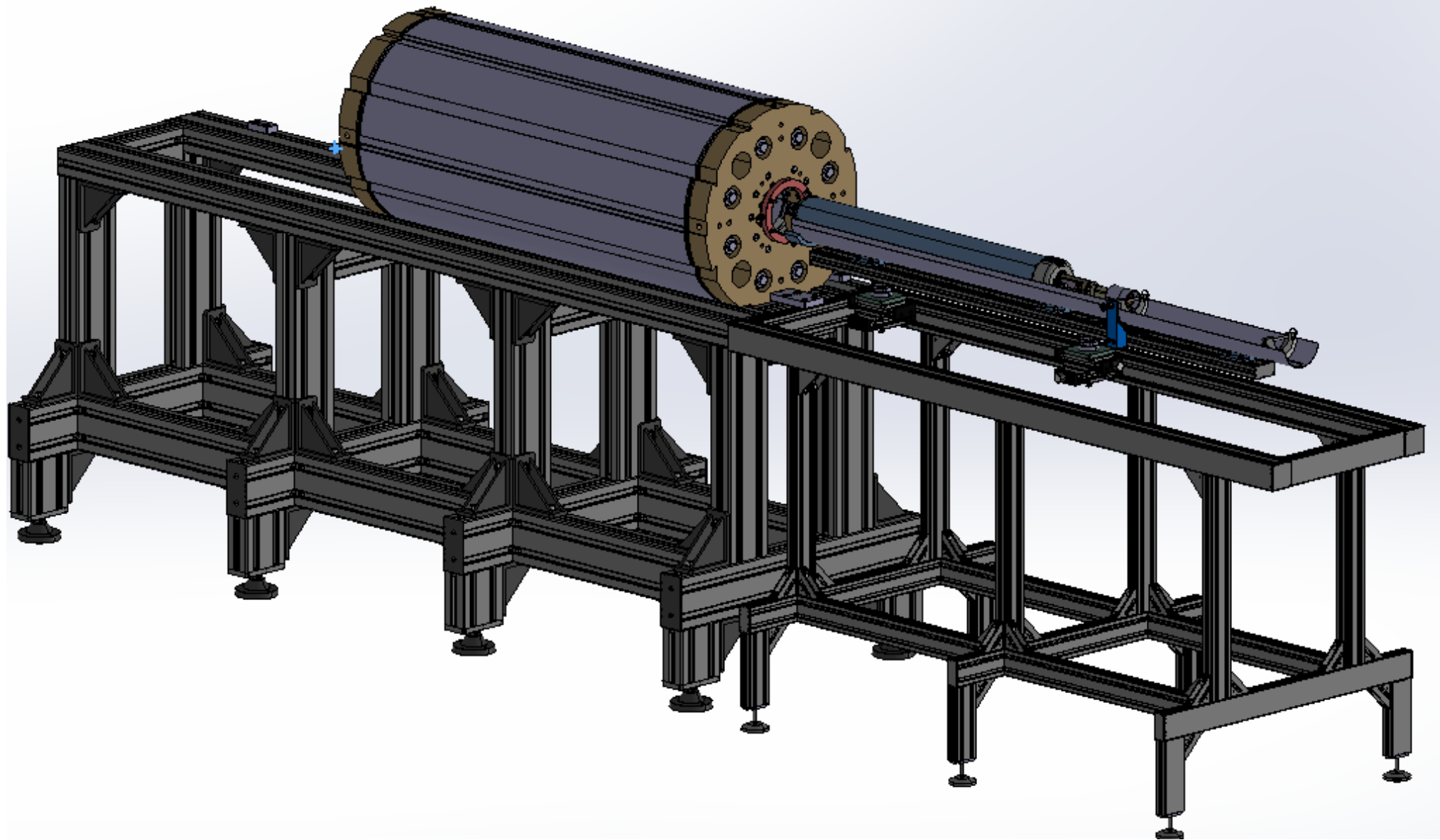

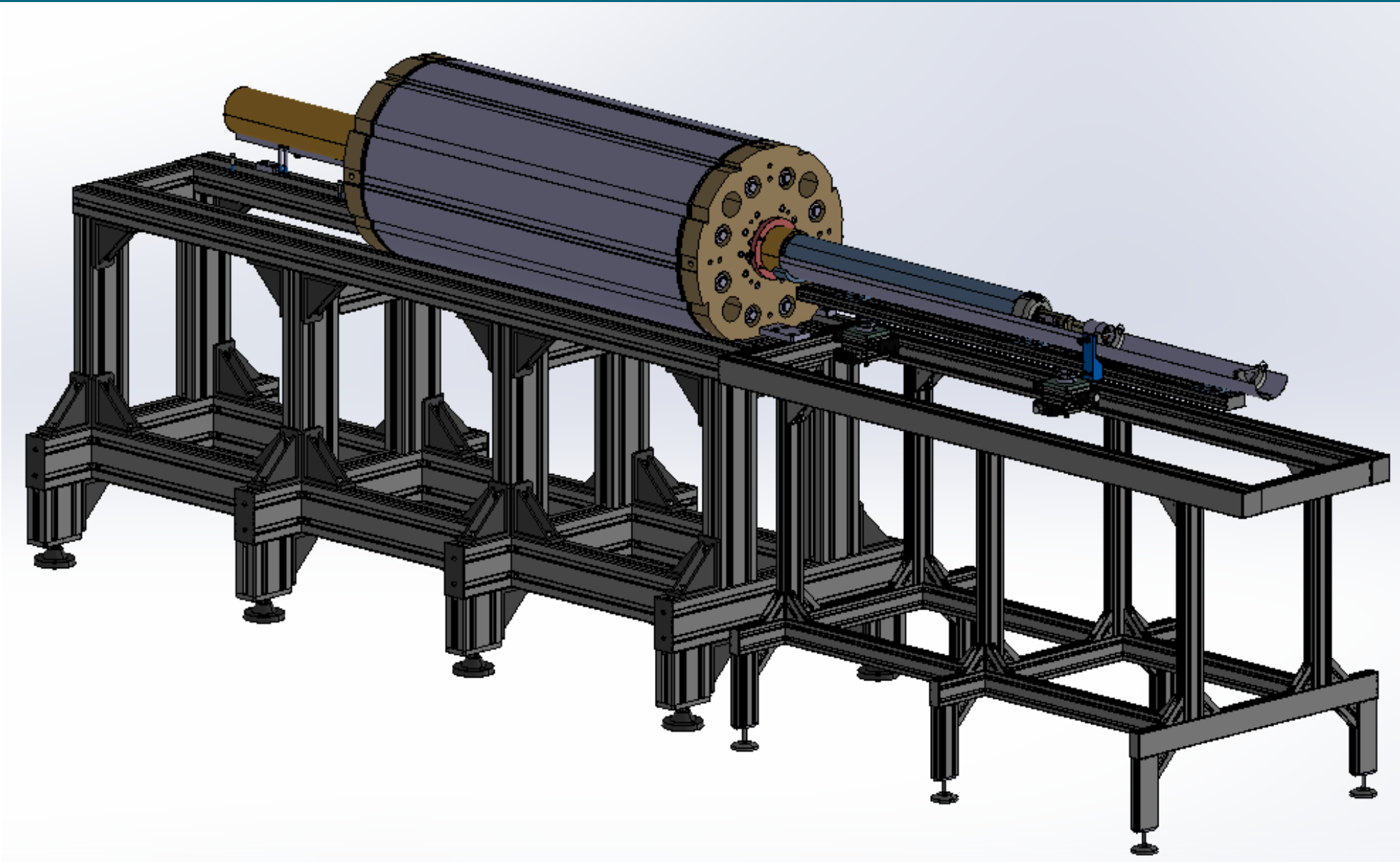

Collared Inner Dipole

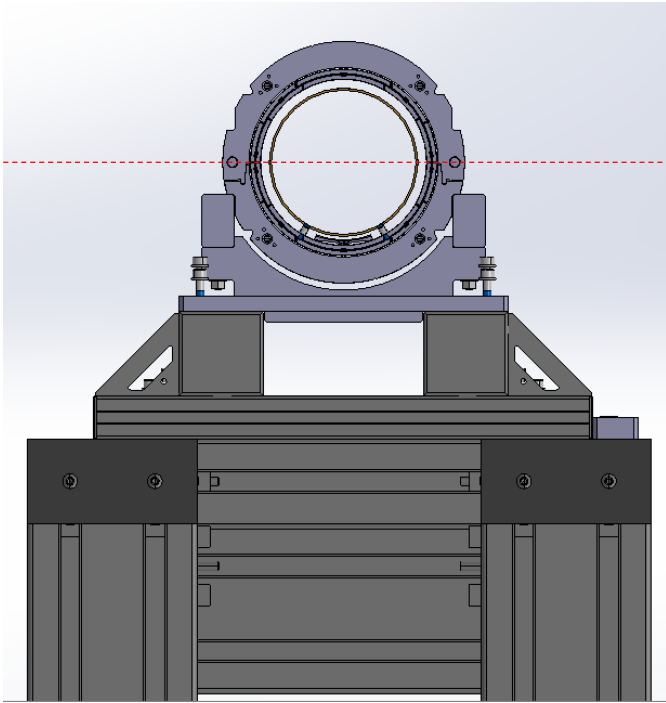

Collared Inner + Outer Dipoles

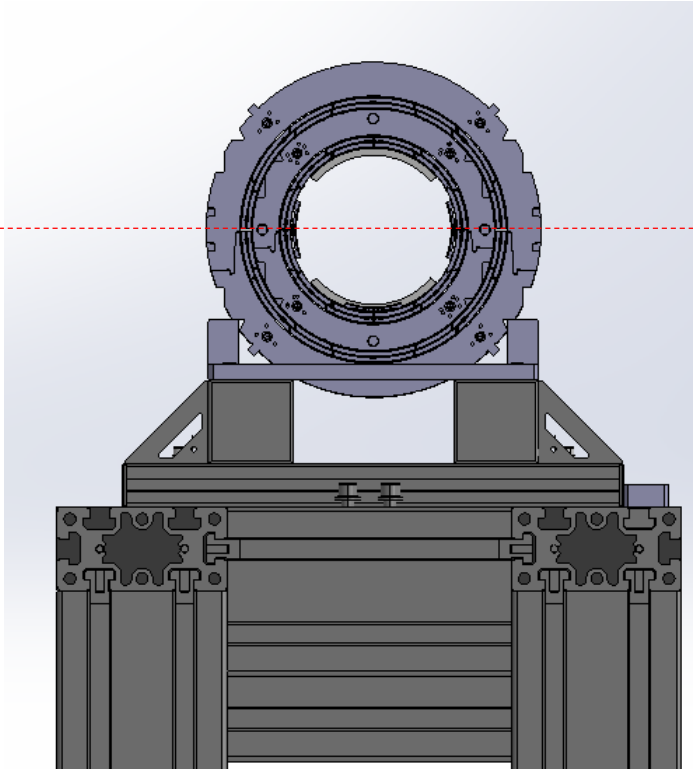

Complete Magnet (Iron)

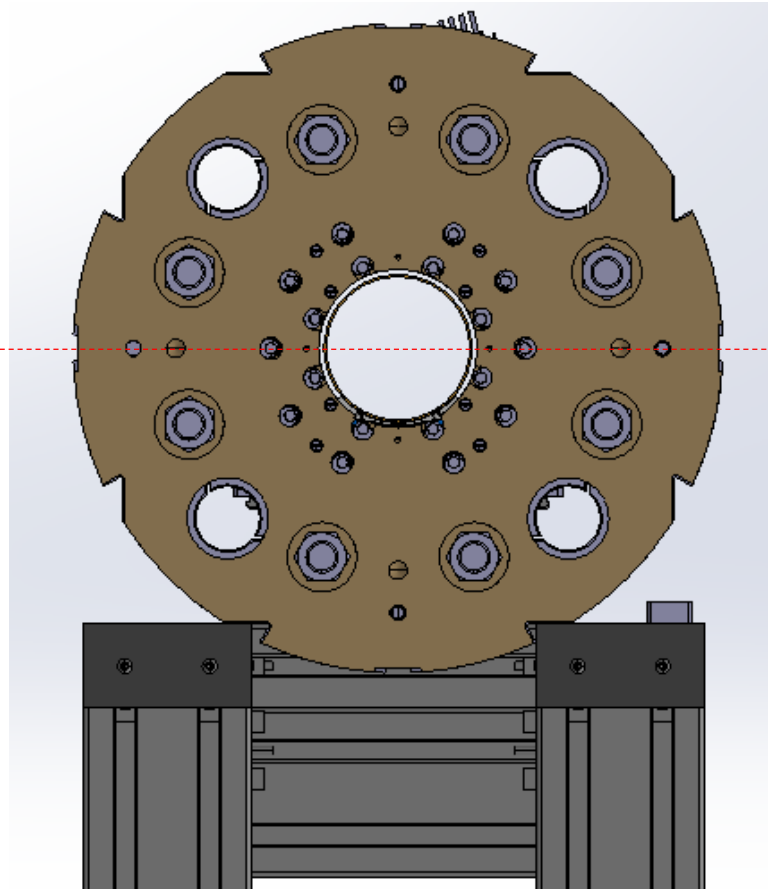

Different adaptation pieces for each fabrication stage

Center of apperture always at the same level

MCBXF WMM at Elytt premises – Operation Protocol

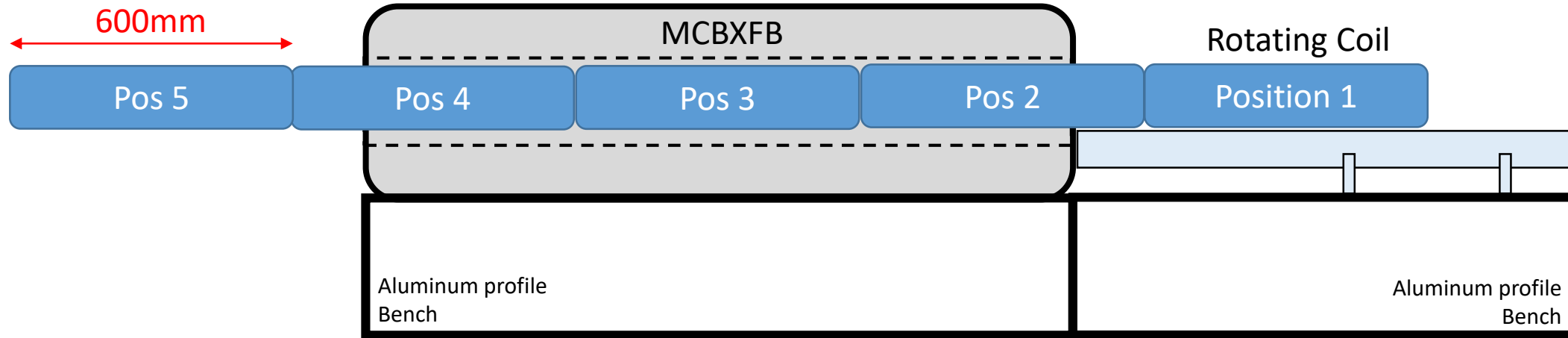

MCBXF WMM at Elytt premises – Operation Protocol

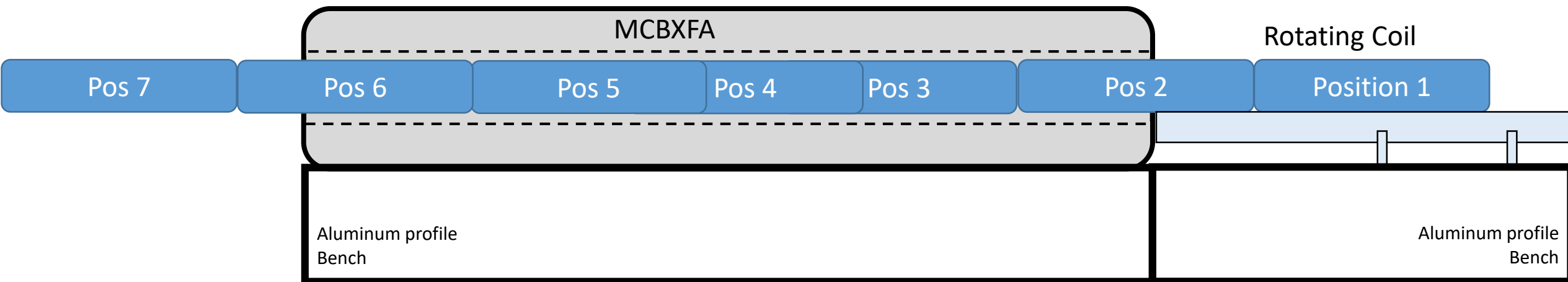
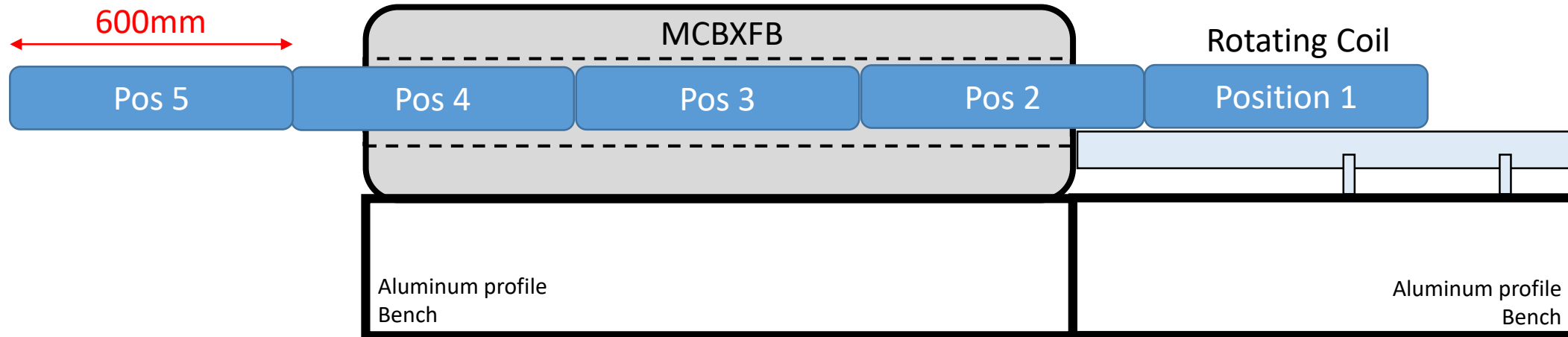

MCBXF WMM at Elytt premises – Operation Protocol

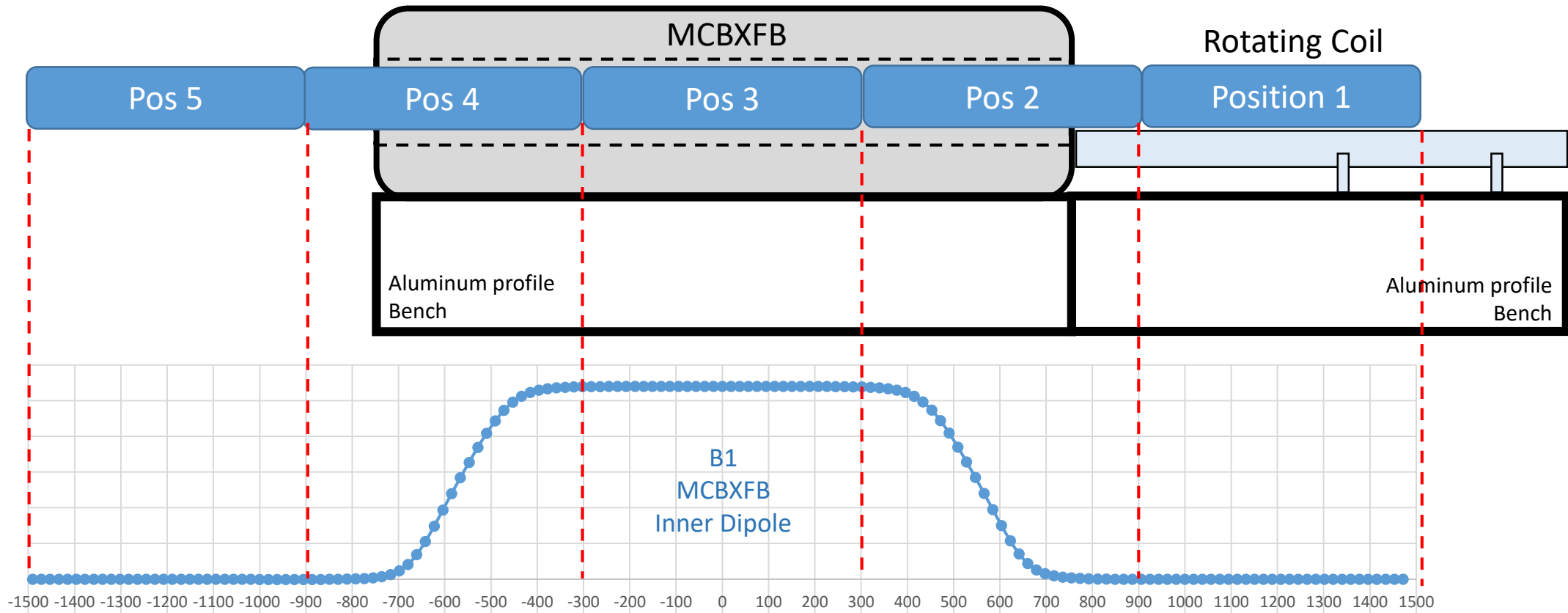

MCBXF WMM at Elytt premises – Operation Protocol

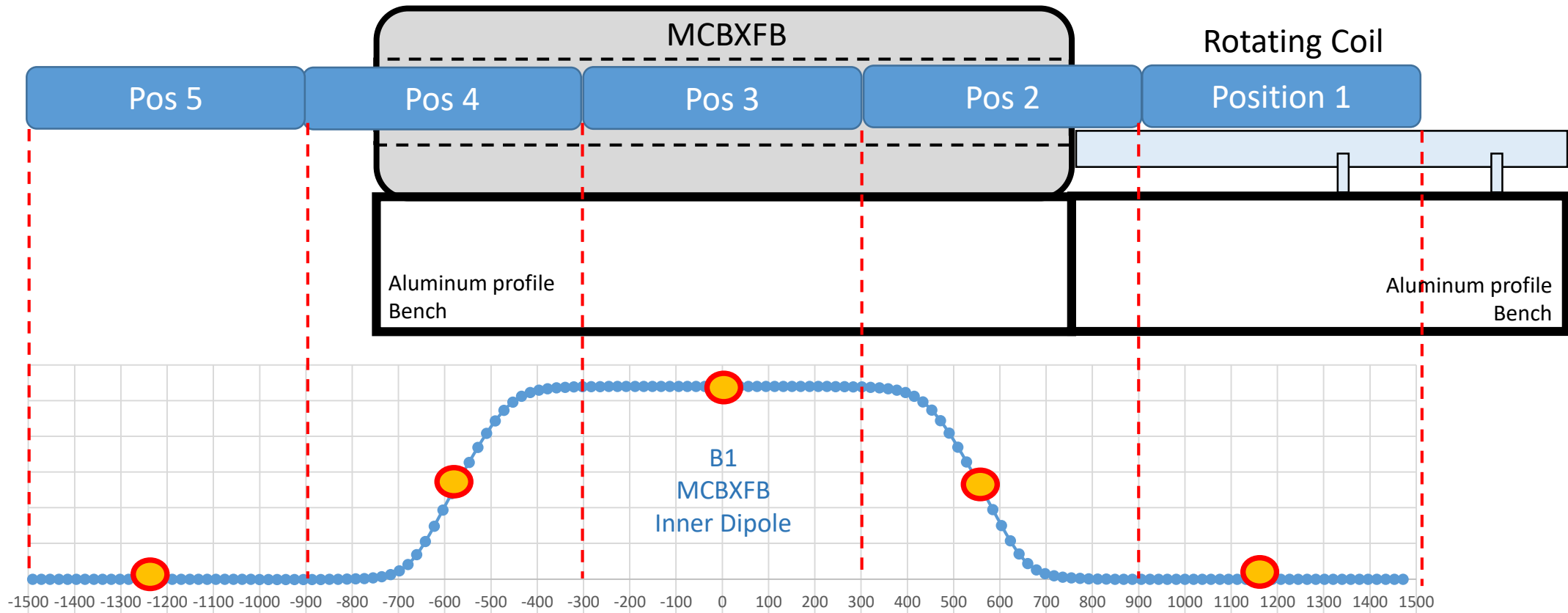

MCBXF WMM at Elytt premises – Operation Protocol

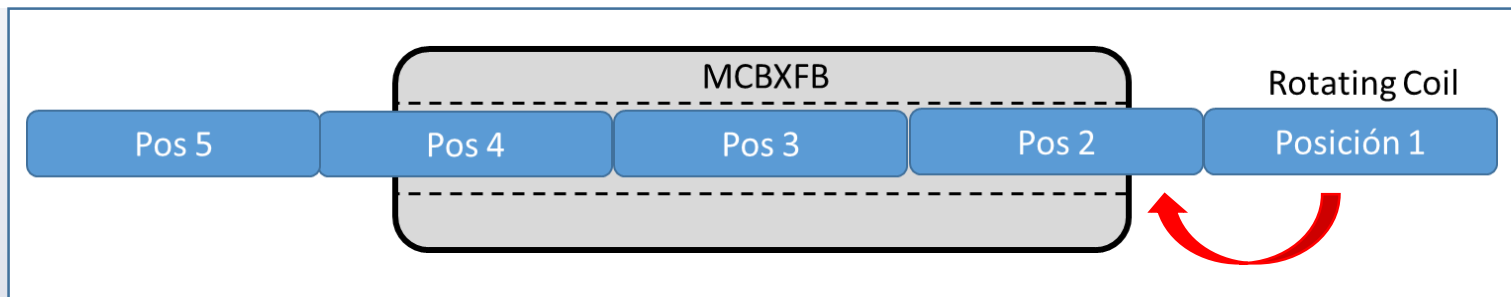
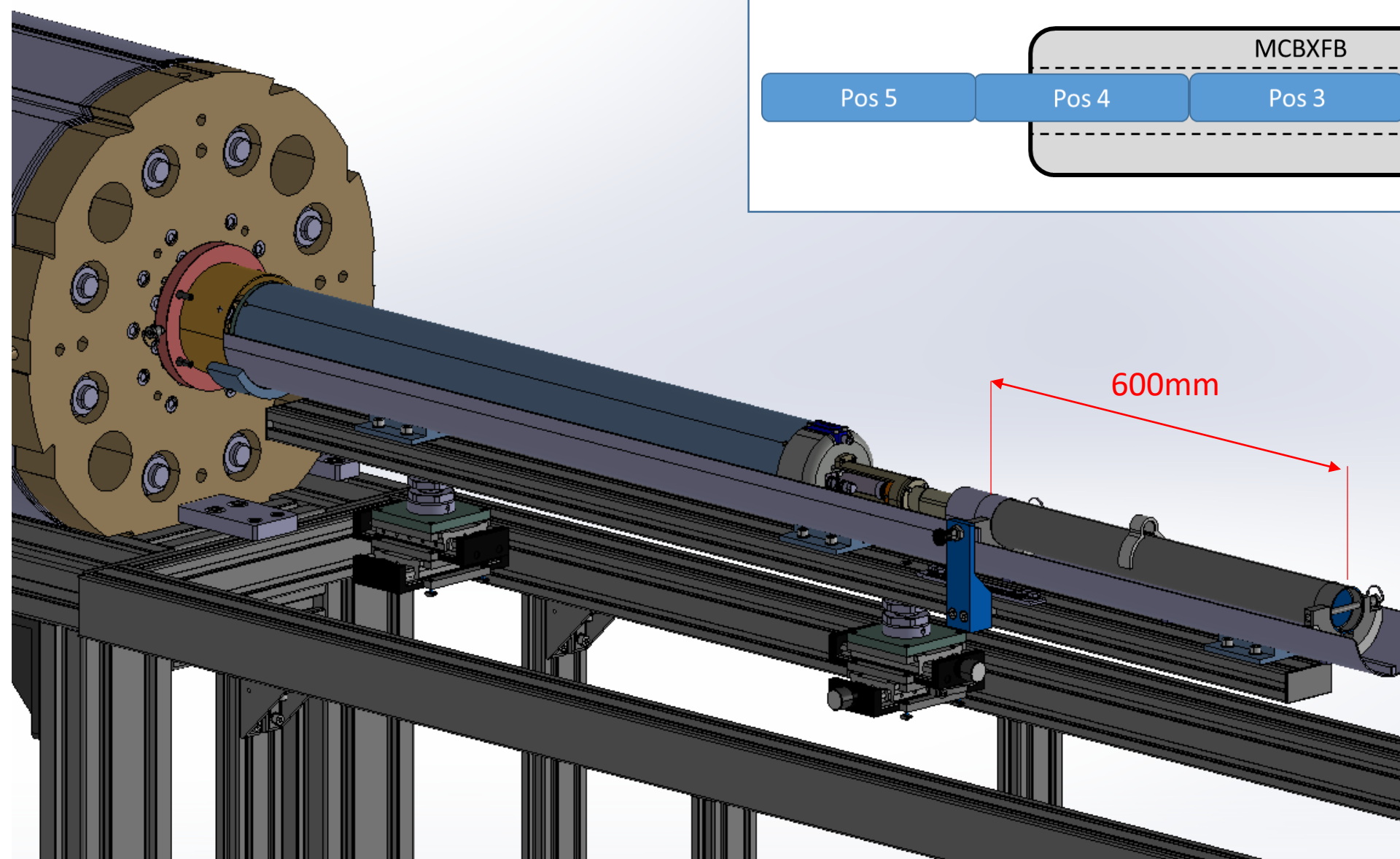

MCBXF WMM at Elytt premises – Operation Protocol – Mole Positioning

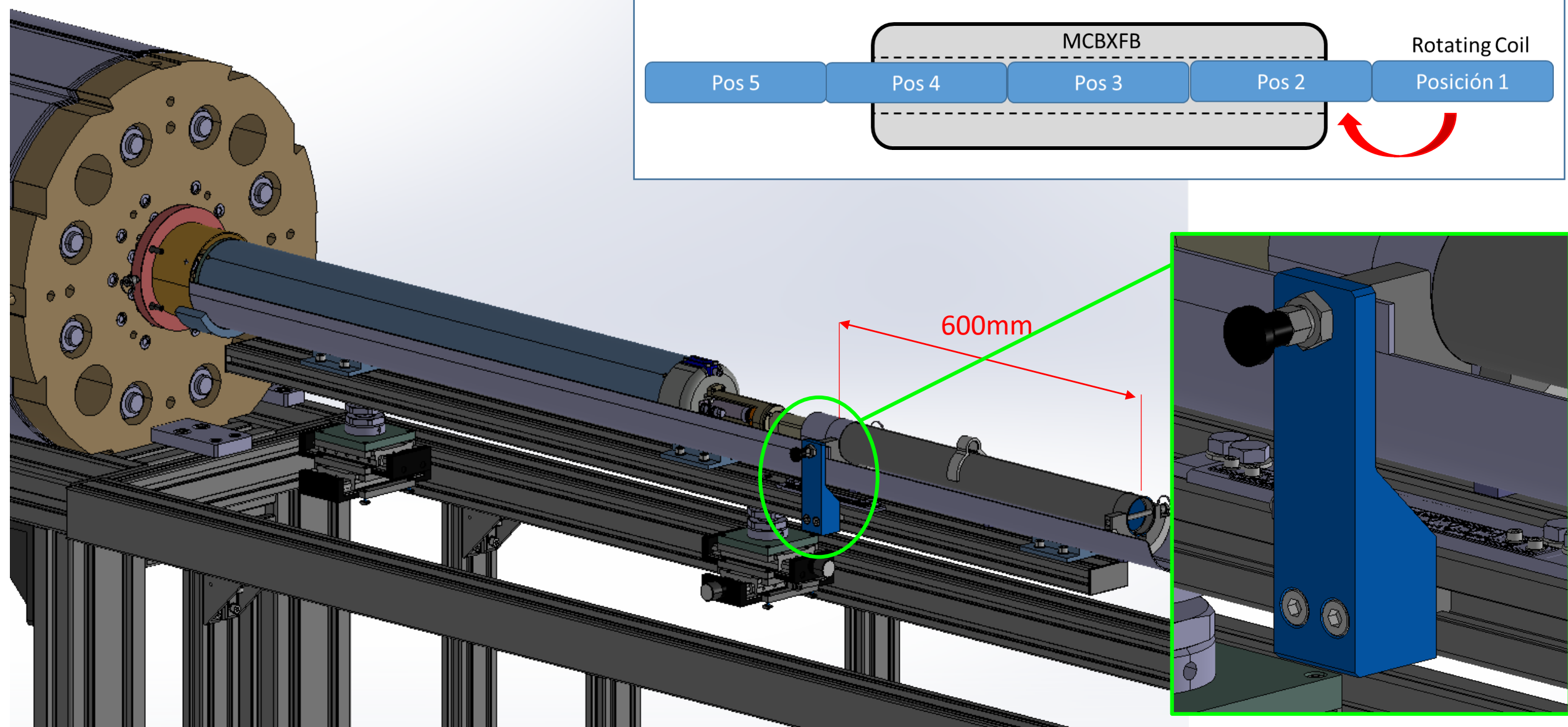

MCBXF WMM at Elytt premises – Operation Protocol – Mole Positioning

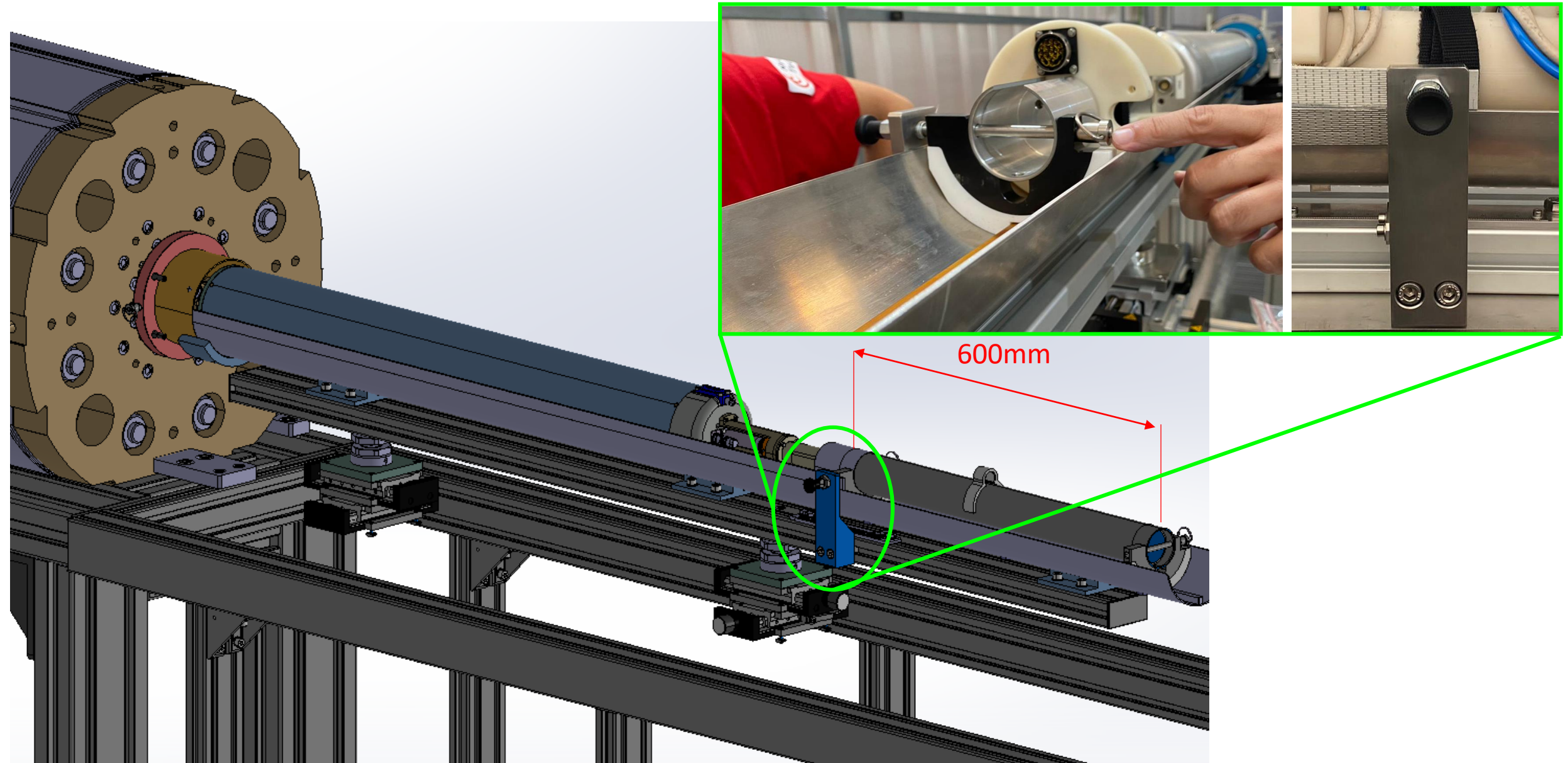

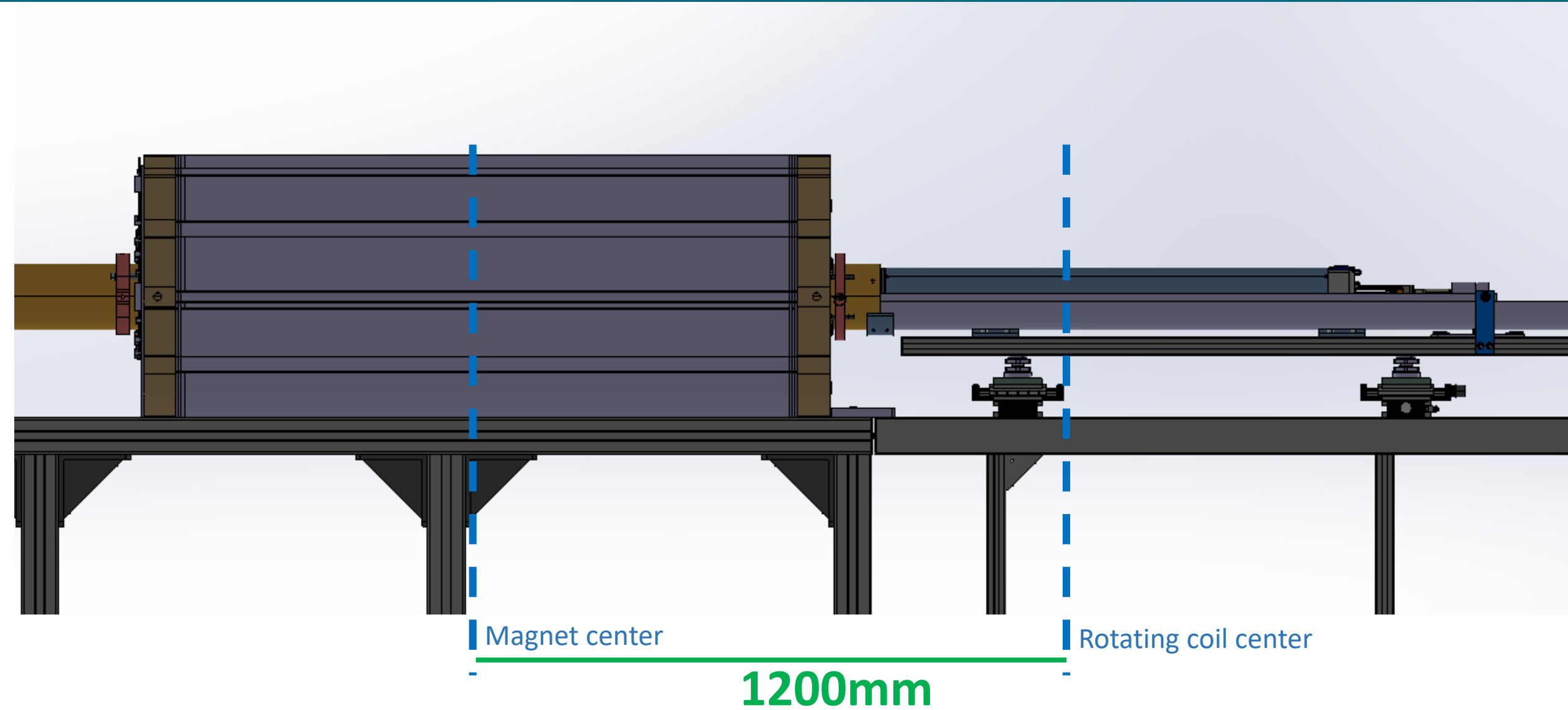

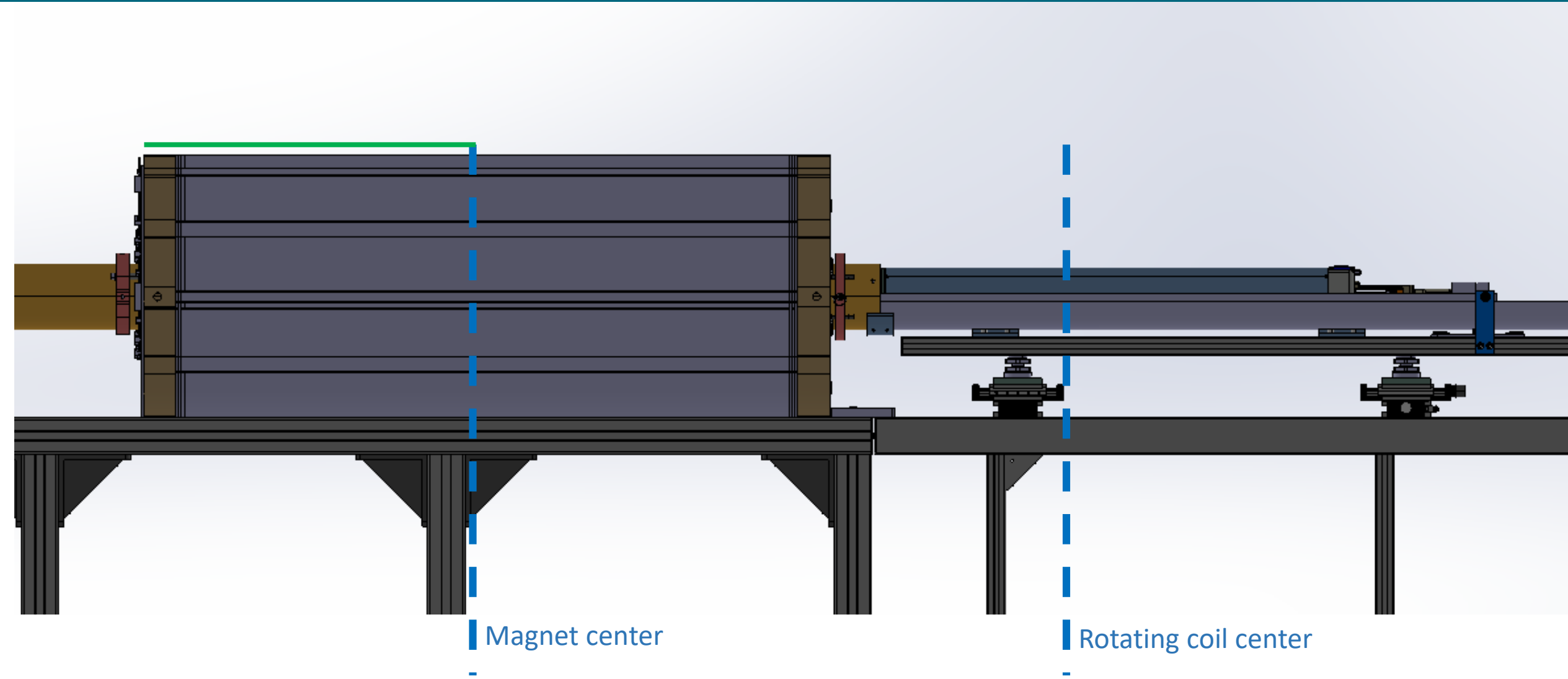

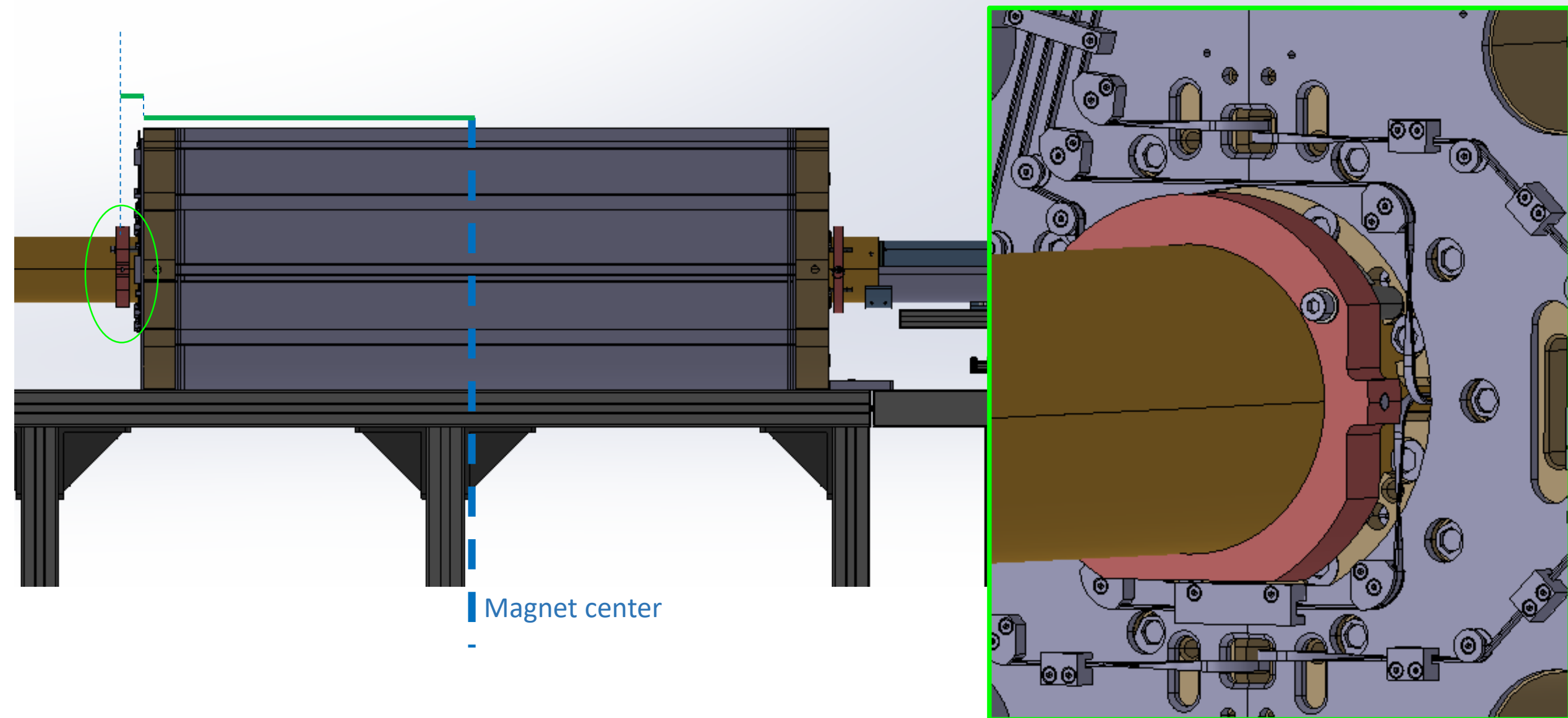

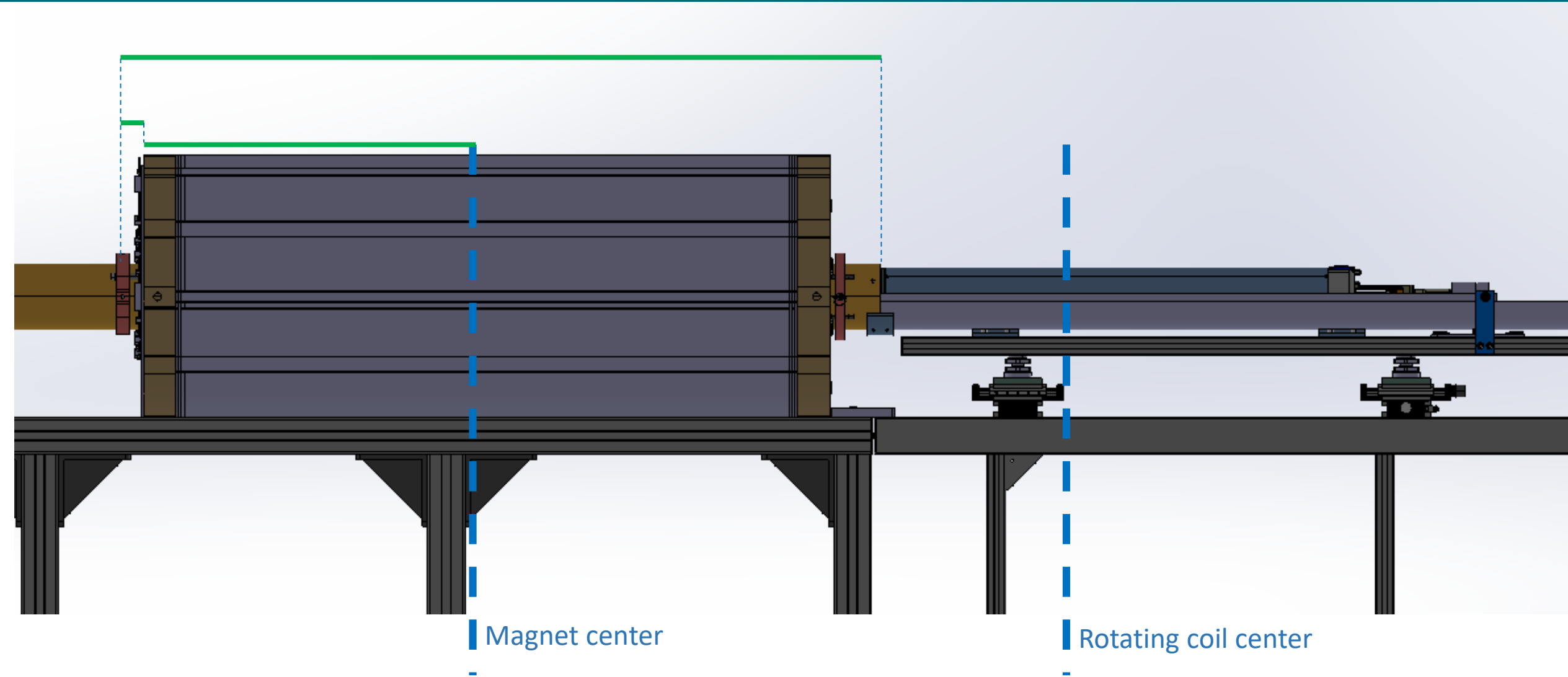

MCBXF WMM at Elytt premises – Operation Protocol – Mole Positioning

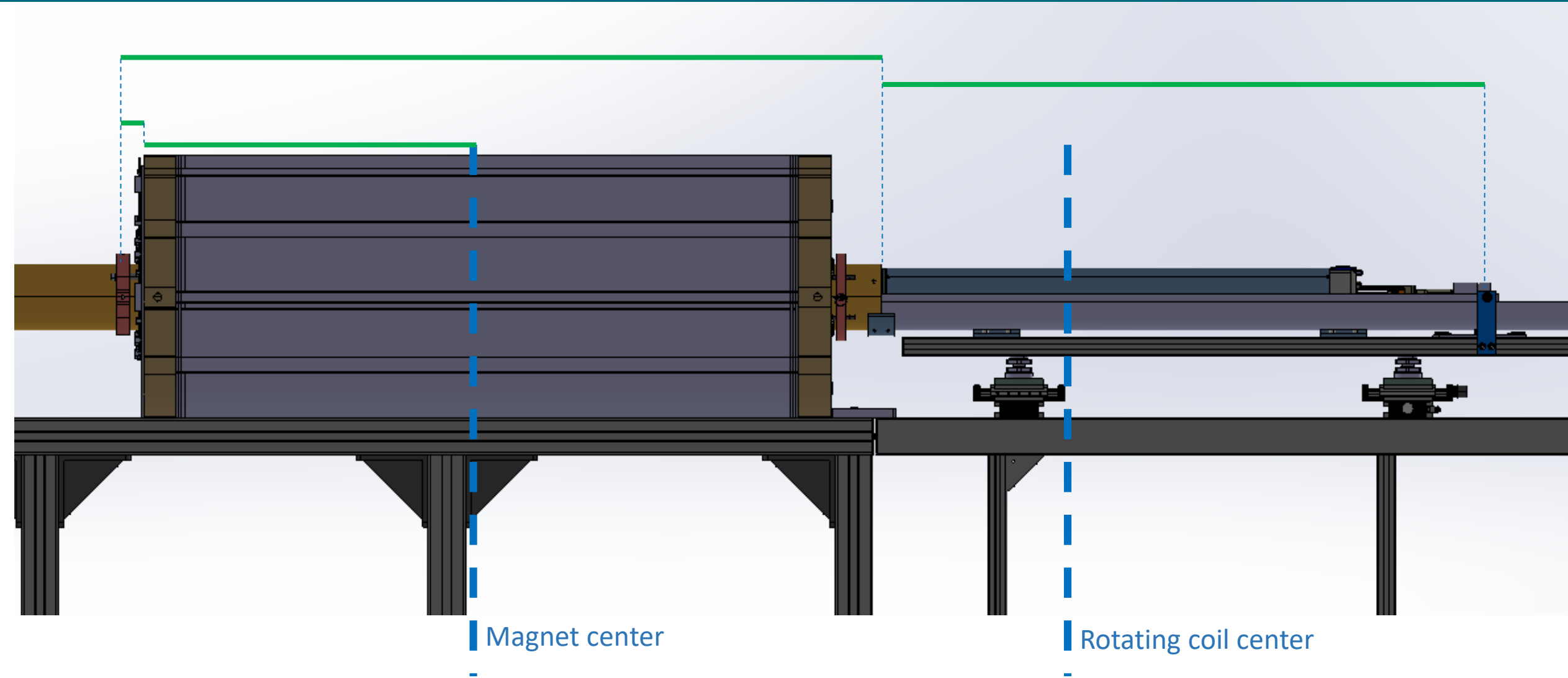

MCBXF WMM at Elytt premises – Operation Protocol – Mole Positioning

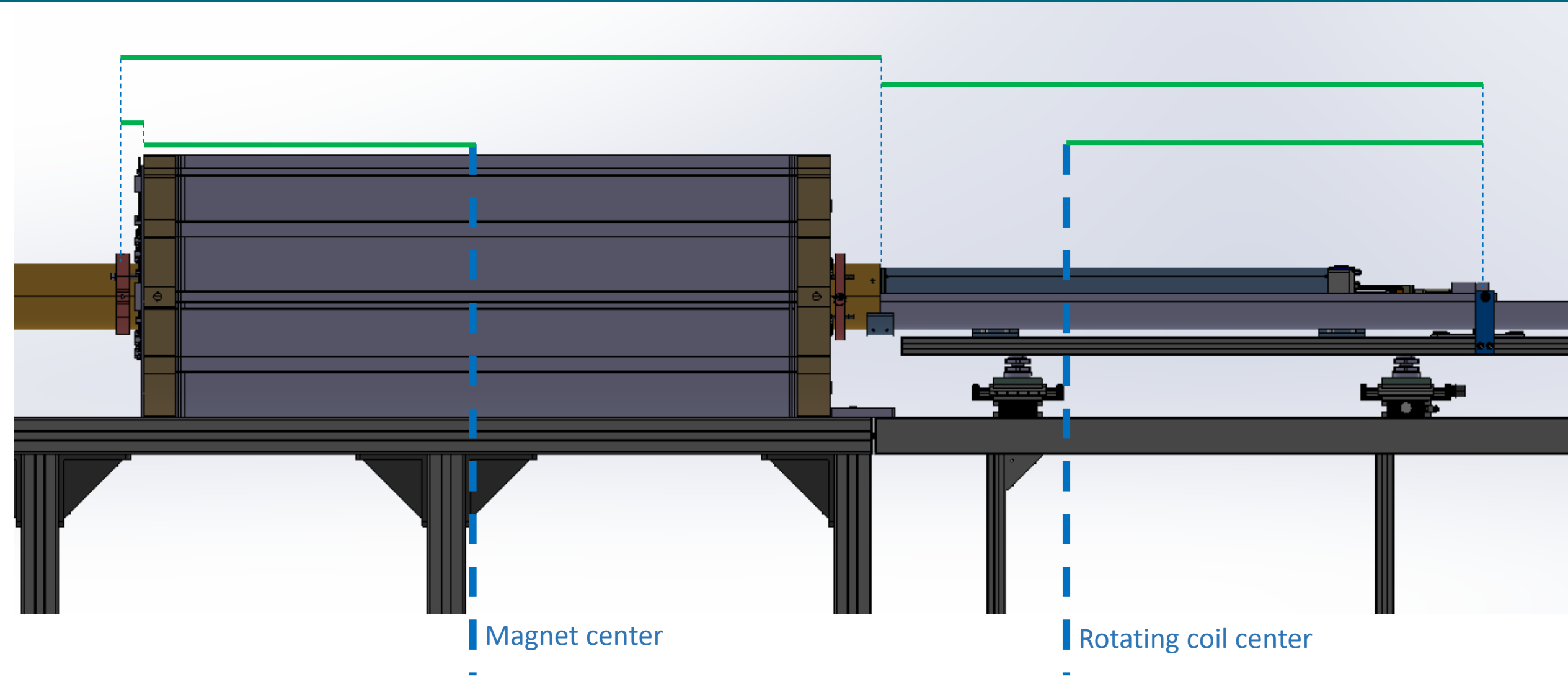

MCBXF WMM at Elytt premises – Operation Protocol – Mole Positioning

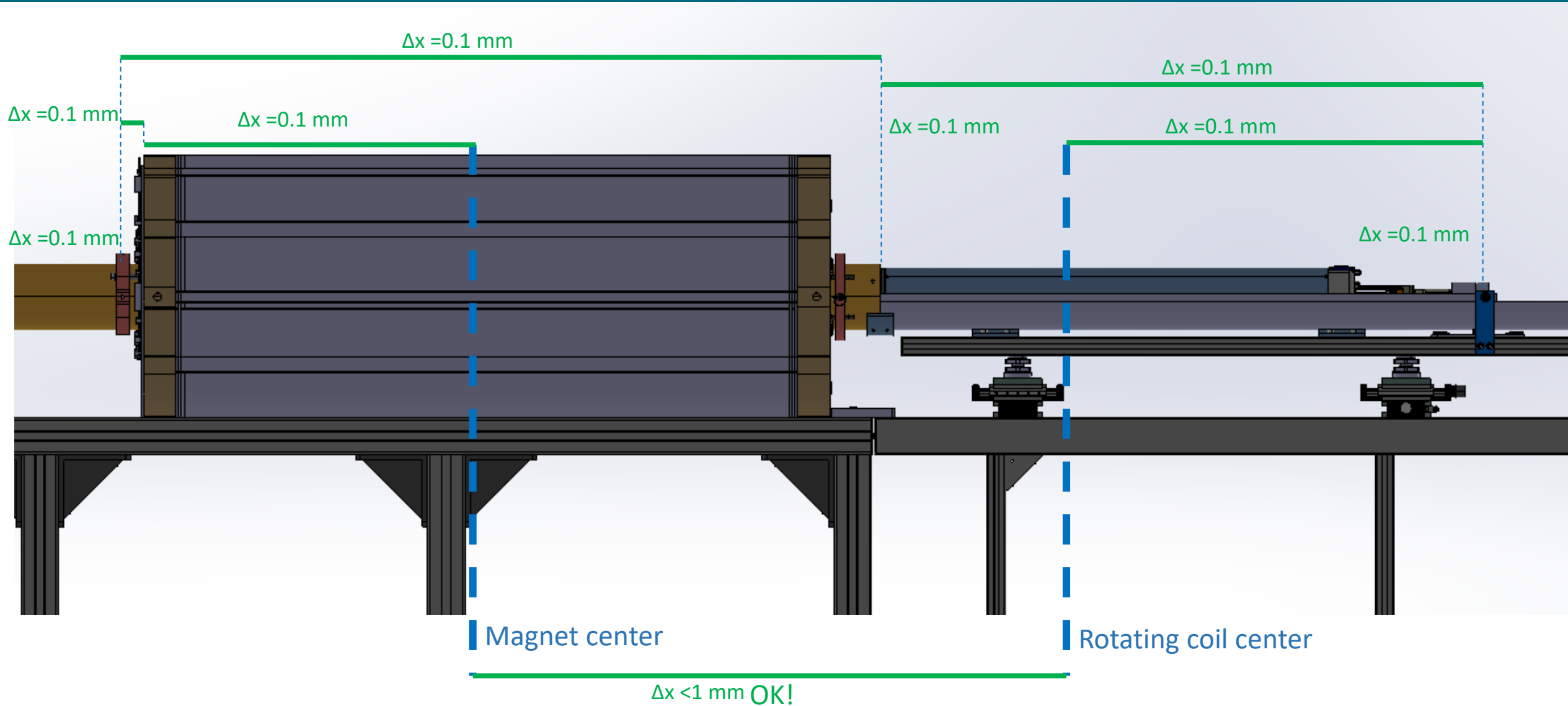

Effect of the 600 mm mole mispositioning at the fringe field

Integrated Roxie field in the 600mm length corresponding to fringe field region:

- No missposition
- + 1mm missposition
- 1 mm missposition

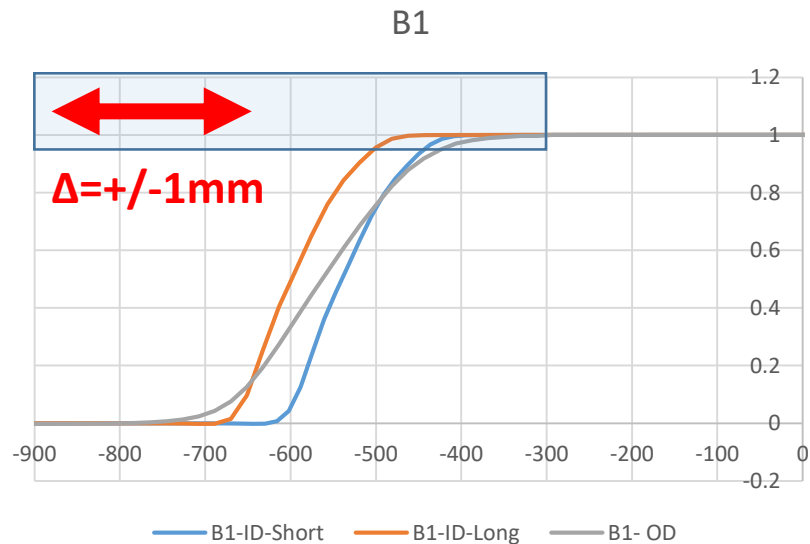

$\Delta = \pm 1\text{mm}$: Error ID = 1.3%
Error OD = 1.2%

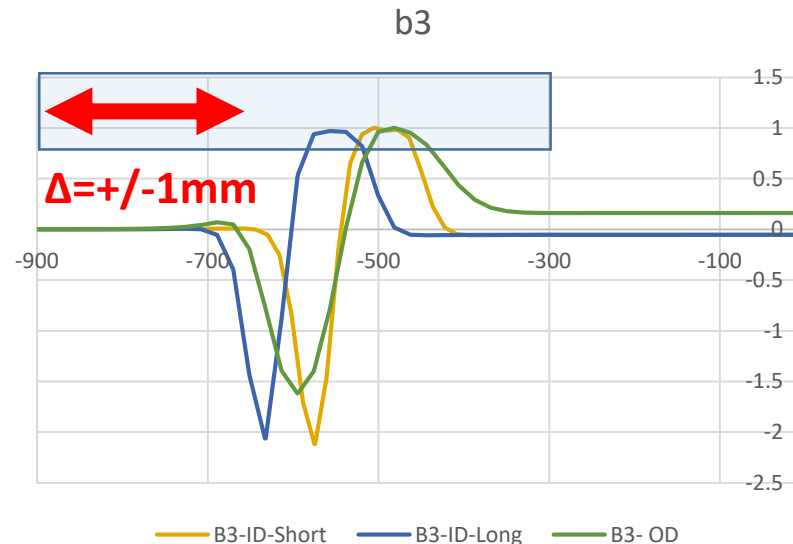

$\Delta = \pm 1\text{mm}$: Error ID = 0.07 μd
Error OD = 0.01 μd

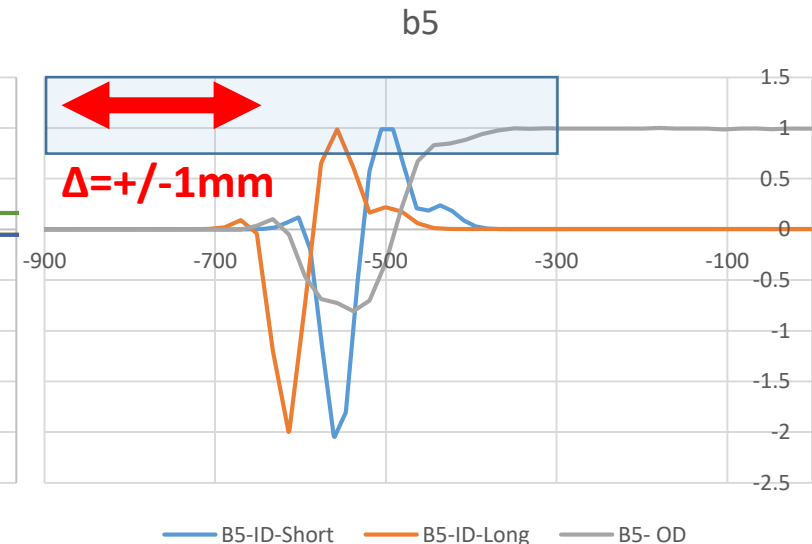

$\Delta = \pm 1\text{mm}$: Error ID < 0.01 μd
Error OD < 0.01 μd

MCBXF WMM at Elytt premises – Controls

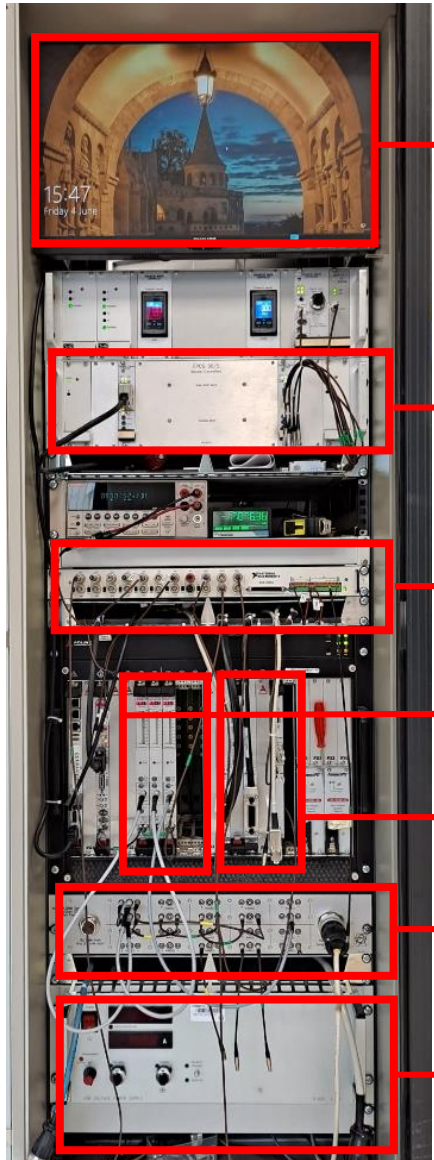

Monitor

Motor
Controller

Daq
(Data Acquisition Card)

Fast Digital
Integrators (CERN)

Encoders

Compensation
panel

Power converter (5 A)

MCBXF WMM at Elytt premises – Controls

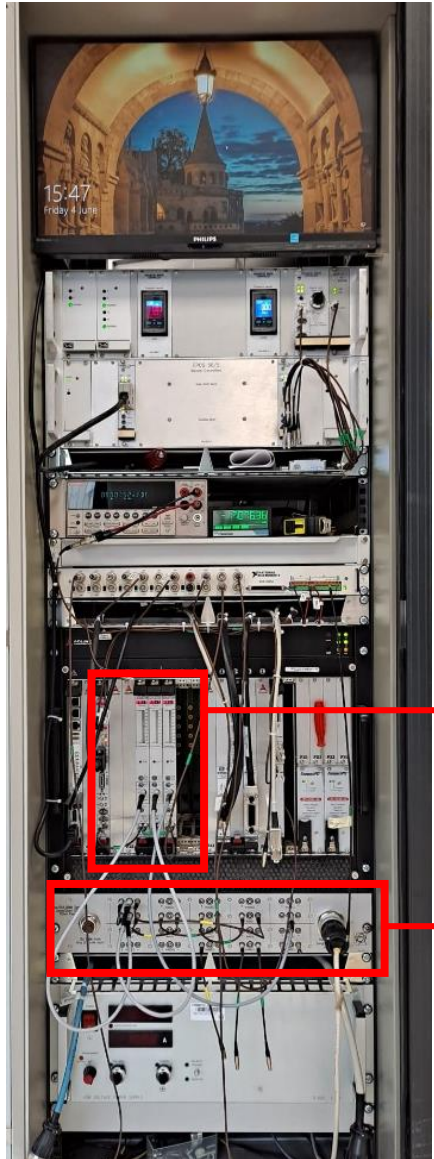

Fast Digital Integrators (CERN)

Compensation panel

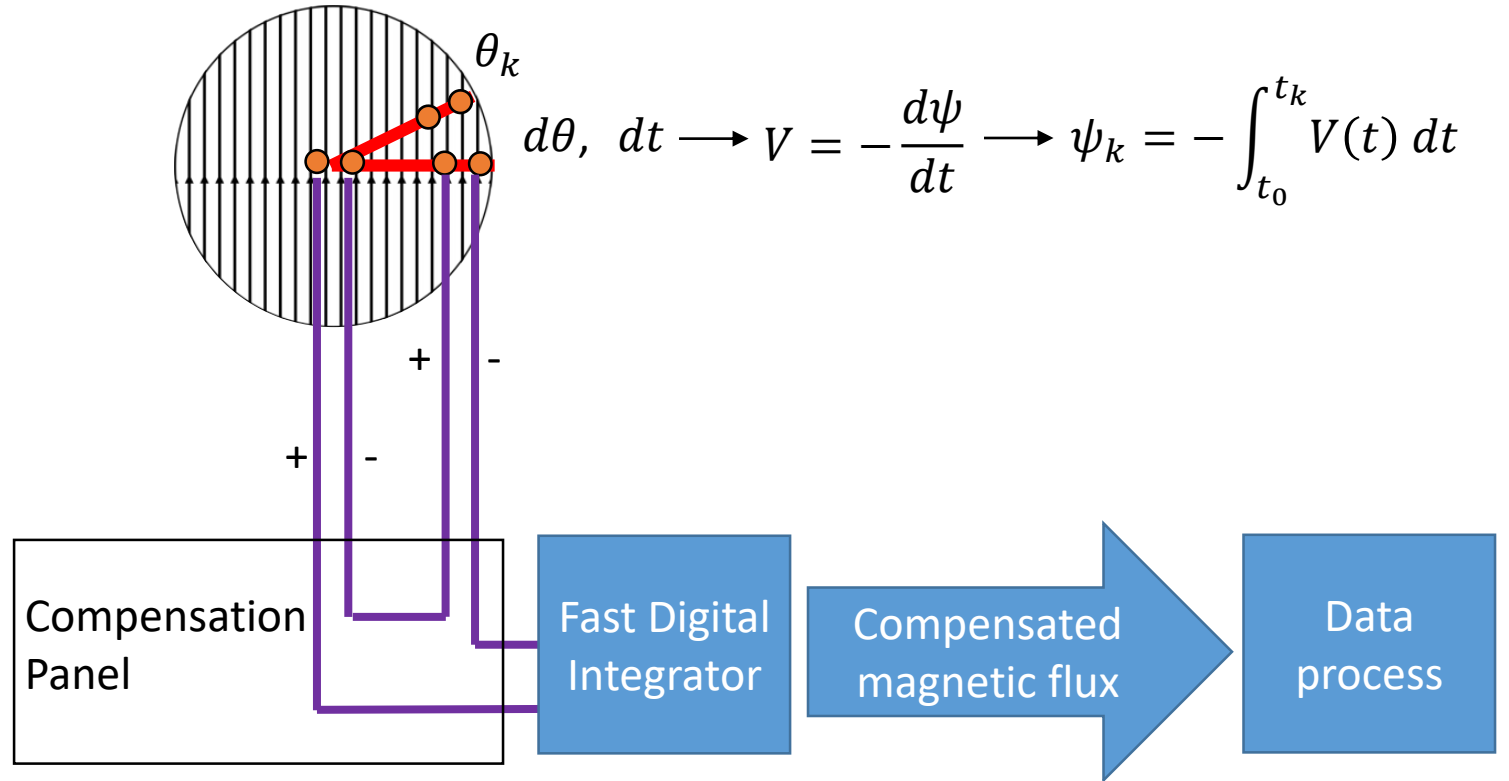

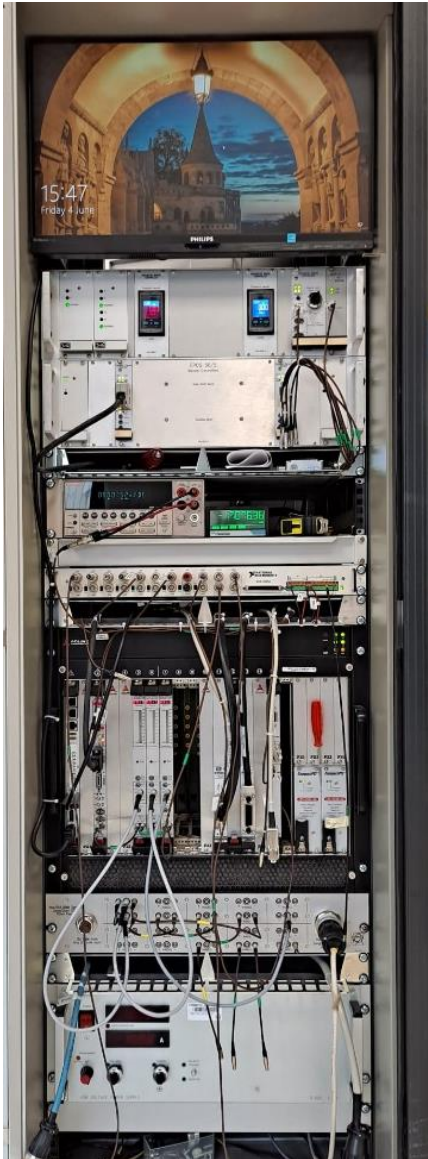

GUI
Control
Data acquisition

C++

Fast Framework for Magnetic
Measurements
FFMM (CERN)

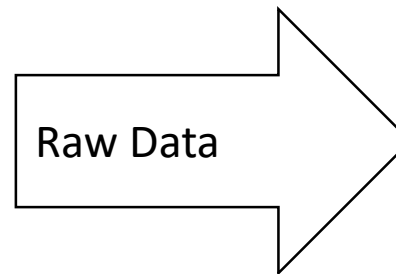

Post processing

Python

CIEMAT

GUI

Script Tab Parameters Acquisition

Rotating Coil Parameters

Measurement

Operator name:

Magnet measurement information

Magnet:

Serial number:

Inner/Outer:

Magnet Orientation

Select:

Upper Coil

Lower Coil

Fabrication stage

Coil length [mm]

Data analysis

Output directory:

Debug

Use Power Converter

Current (separator ;): [A]

Gain

Gain for absolute signals:

Gain for compensated signals:

Rotate in both directions

Measure in a single position

Controls

Post-processing at CIEMAT

Results on the MCBXFB02

First magnet of the series completely manufactured at Elytt

Collared Inner Dipole



Collared Inner + Outer Dipoles

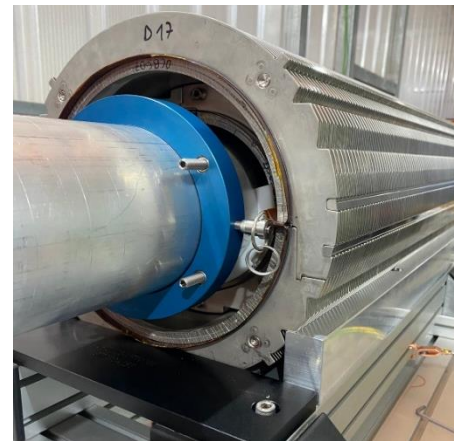

Complete Magnet (Iron)

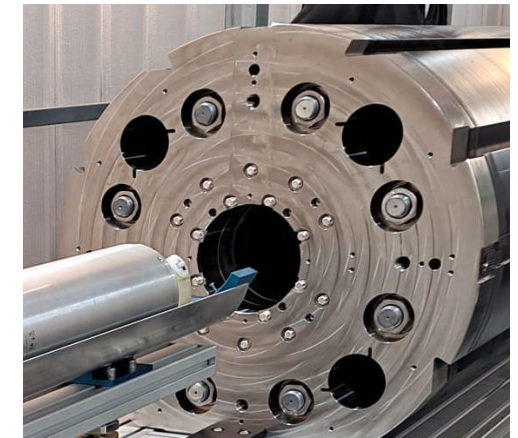

Inner Dipole

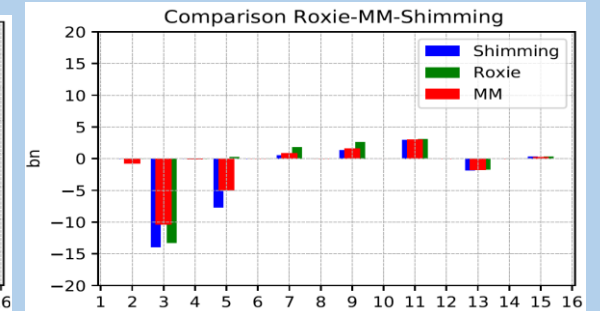
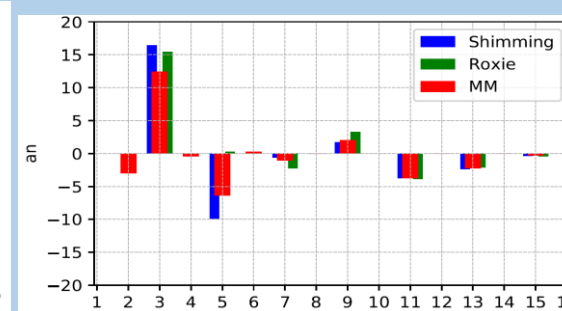
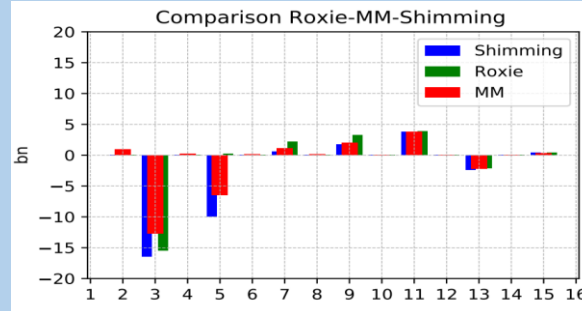

Outer Dipole

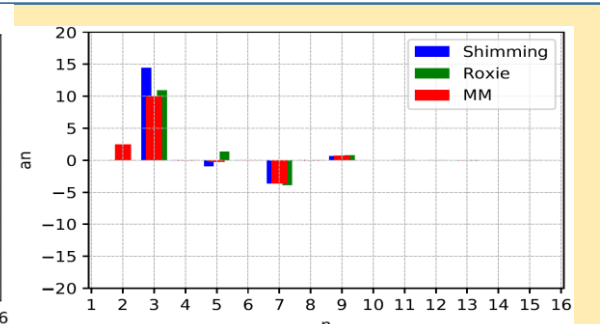
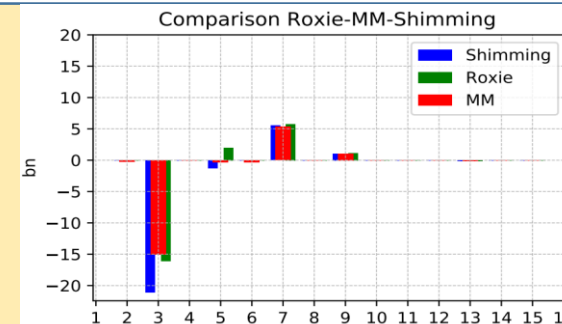

Reference System - Rotations

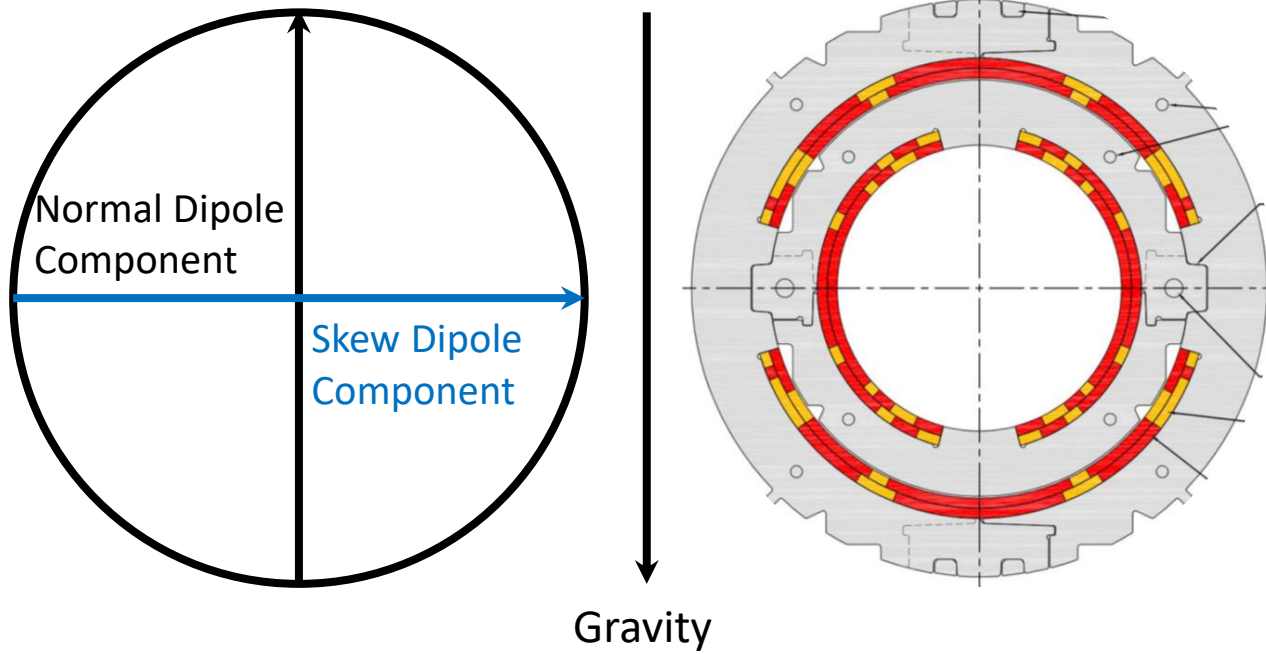

Roxies' Reference System

Animesh K. Jain Basic Theory of Magnets

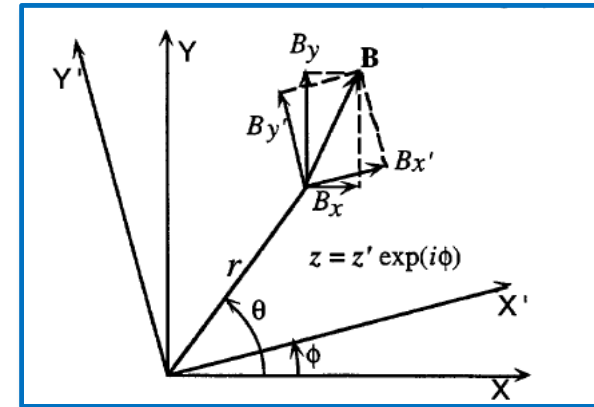

$$B' + iA' = (B + iA)e^{in\varphi}$$

$$\varphi = 90^\circ$$

$$n=4,8,12\dots$$

$$B'n = Bn$$

$$A'n = An$$

$$n=1,5,9,13\dots$$

$$B'n = -An$$

$$A'n = Bn$$

$$n=2,6,10,14\dots$$

$$B'n = -Bn$$

$$A'n = -An$$

$$n=3,7,11,15\dots$$

$$B'n = An$$

$$A'n = -Bn$$

Reference System - Reflections

Introduce Mole from **Non Connection side**
For operational simplicity

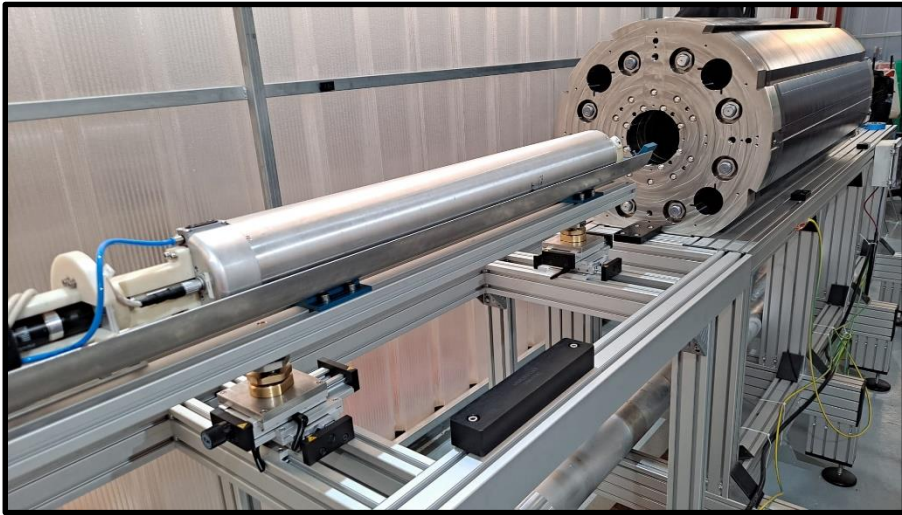

Multipole values defined from **Connection Side**
(Also Roxie's Reference system)

Animesh K. Jain Basic Theory of Magnets

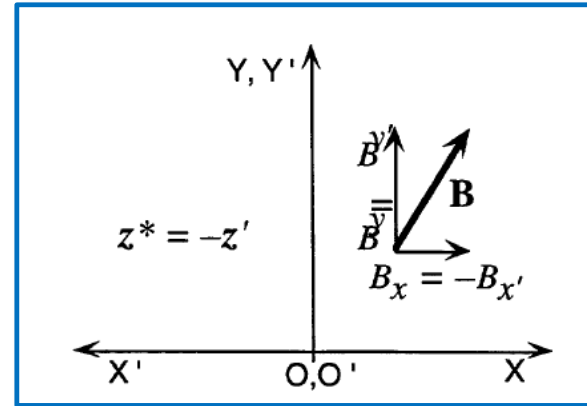

$$B'_n = (-1)^{n+1} B_n$$

$$A'_n = (-1)^n A_n$$

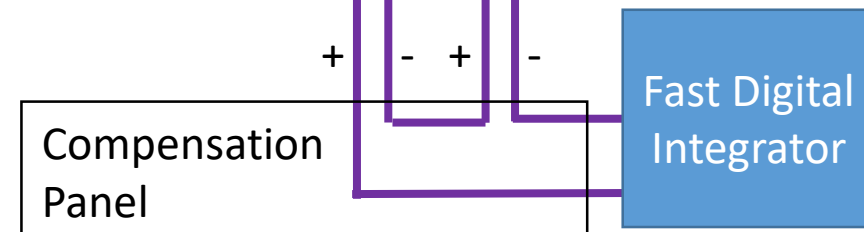
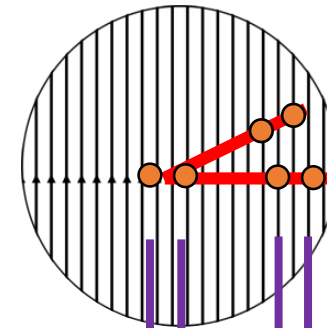

Reference System - Reflections

Introduce Mole from **Non Connection side**
For operational simplicity

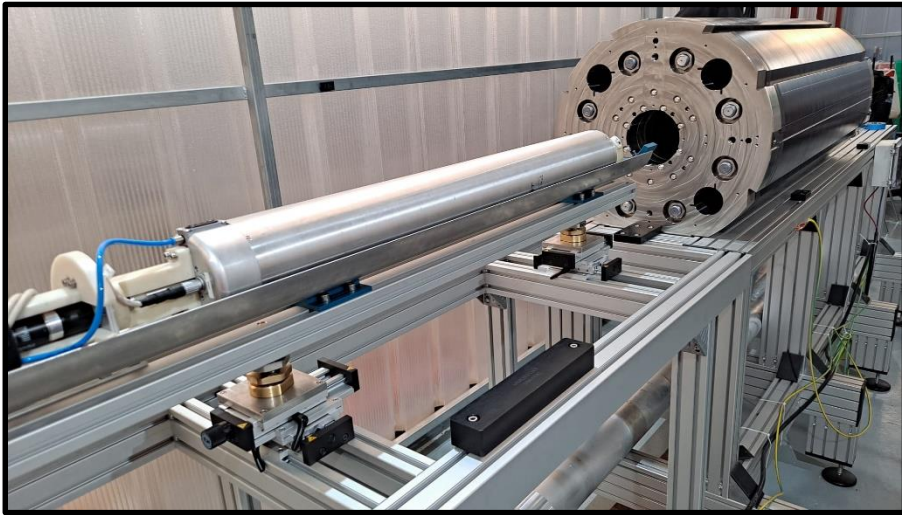

Multipole values defined from **Connection Side**
(Also Roxie's Reference system)

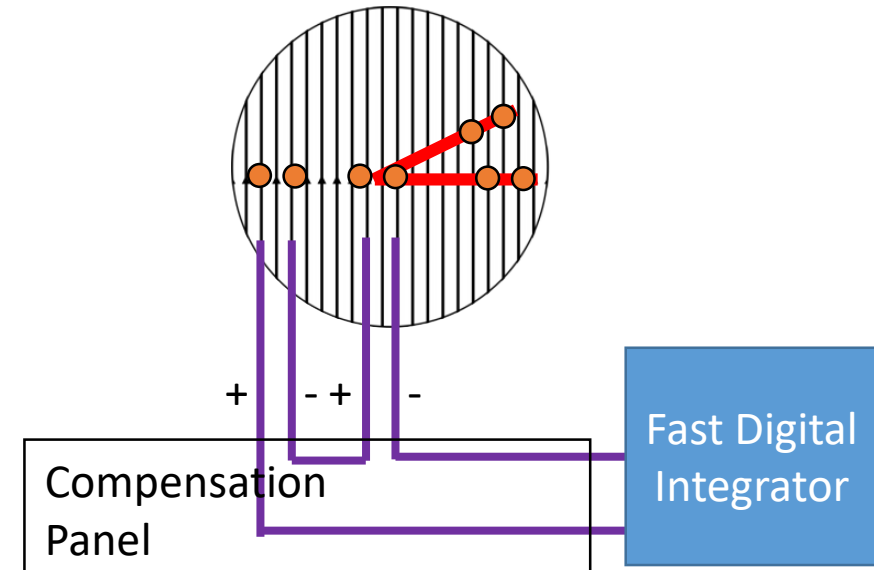
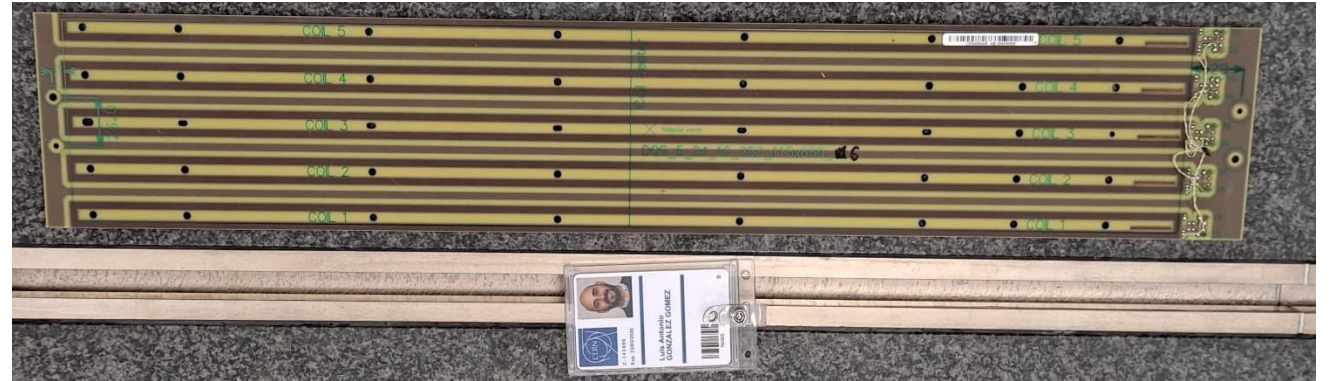

Series production of MCBXF orbit corrector magnet for HL-LHC has started at Elytt

A dedicated Testbench has been designed and manufactured to carry out the WMM after each fabrication stage

The testbench has been designed to be robust and with limited operation flexibility in order to optimize its performance at the industry premises

Simplified strategy for mole positioning

Tailor made GUI and data acquisition and data post processing codes

Special care was taken regarding reference system transformations

Measuring campaign on MCBXFB02 was successfully performed