



... riding the wave

A Stretched Wire Tomography System at Kyma

Mirko Kokole

Introduction

- **Technique of SW tomography first proposed and demonstrated by ESRF at IMMW21 in Grenoble in 2019**
- **Kyma already has a Small Stretched Wire Bench**
 - *Characterization of single magnets and small modules*
- **Adaptation of the SW Bench to a SW Tomography system**
 - *Addition of only one rotary stage necessary*

Radon Transform and Field Integrals

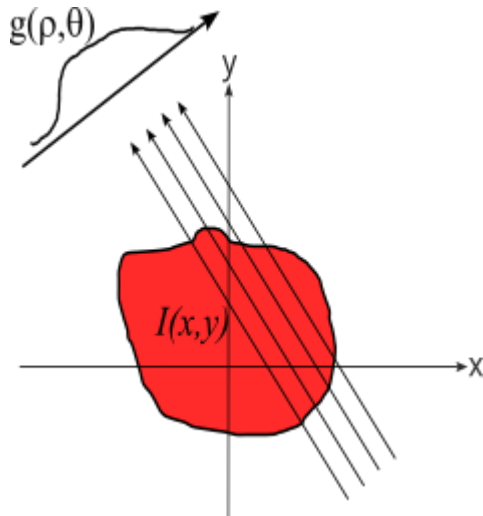

Radon transform is a path integral along the line $L(\rho, \theta)$ of the function $I(x, y)$.

$$L(\rho, \theta) = \{(x, y) \in \mathbb{R} \times \mathbb{R}: x \cos(\theta) + y \sin(\theta) = \rho\}$$

$$g(\rho, \theta) = \int_L I(x, y) ds$$

Field integral is a path integral of the magnetic field density along a specific line.

$$I_{zL}(\rho, \theta) = \int_L B_z(x, y) ds$$

- Field integral over a line L is equivalent to the Radon transform of the magnetic field along the line L .
- From field integral measurements scans at different angles we can reconstruct a 2D map of the magnetic field density.
- A stretched wire bench with a rotary stage can be used to measure 2D magnetic field map.

A Simple Back Projection - Laminograms

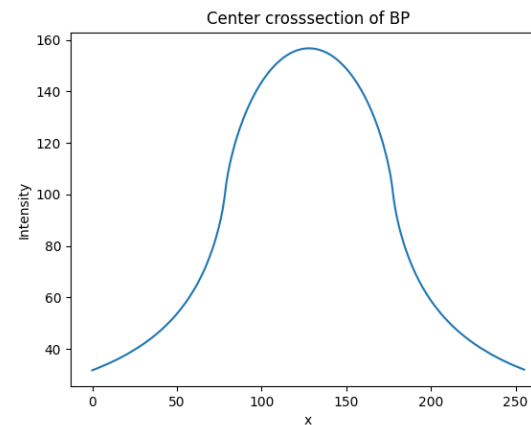
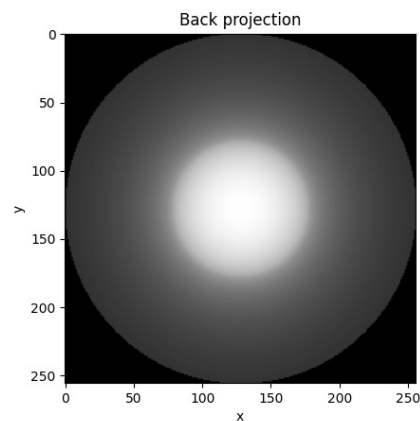
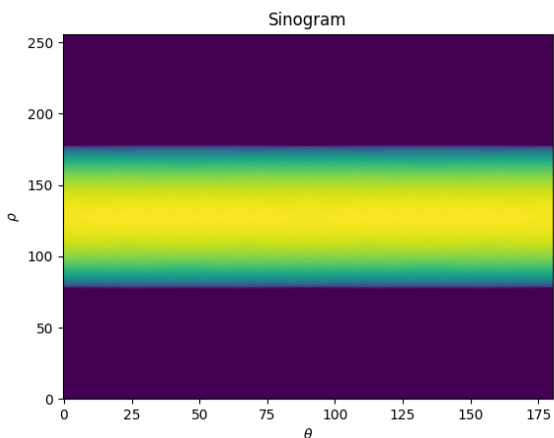
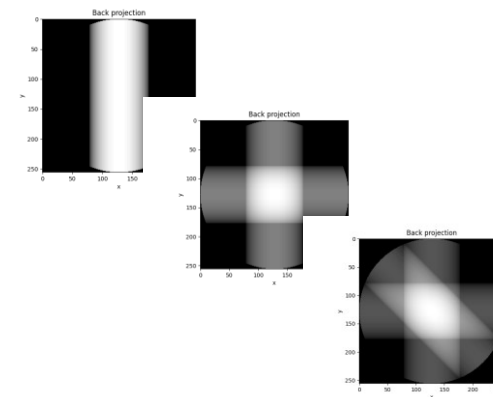
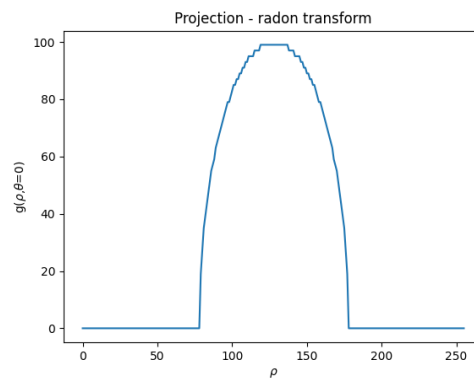
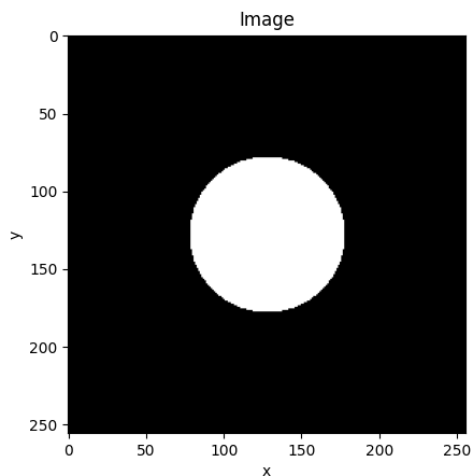



Inverse Radon T. and Fourier Slice Theorem

$$g(\rho, \theta) = \iint I(x, y) \delta(x \cos(\theta) + y \sin(\theta) - \rho) dx dy \quad \text{A projection function}$$

$$G(\omega, \theta) = \int_{-\infty}^{\infty} g(\rho, \theta) e^{-i2\pi\omega\rho} d\rho \quad \text{Fourier transform of a projection function}$$

$$G(\omega, \theta) = \iint_{-\infty}^{\infty} I(x, y) e^{-i2\pi\omega(x \cos(\theta) + y \sin(\theta))} dx dy = \iint_{-\infty}^{\infty} I(x, y) e^{-i2\pi\omega(ux + vy)} dx dy$$

$v = \omega \sin(\theta)$
 $u = \omega \cos(\theta)$

$$I(x, y) = \int_{-\infty}^{\infty} |\omega| G(\omega, \theta) e^{-i2\pi\omega\rho} d\omega$$

Inverse radon transform is a Fourier transform of a $G(\omega, \theta)$ multiplied by a filter function $|\omega|$.

Filtered Back Projection

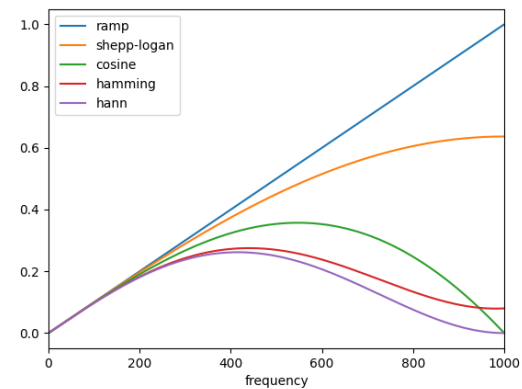
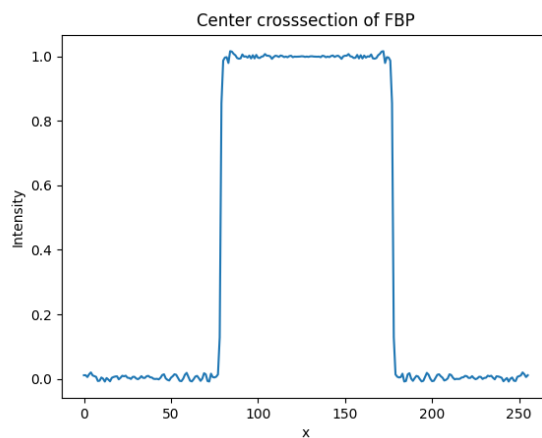
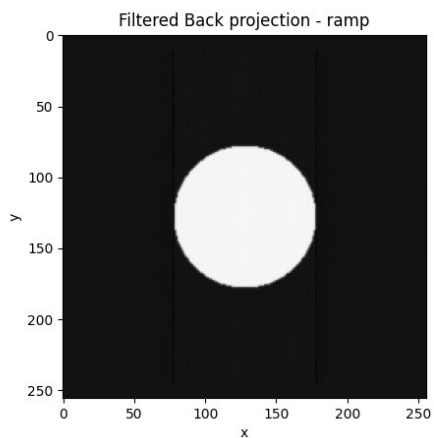
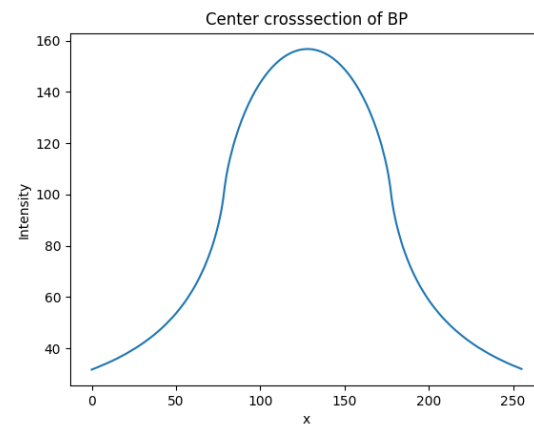
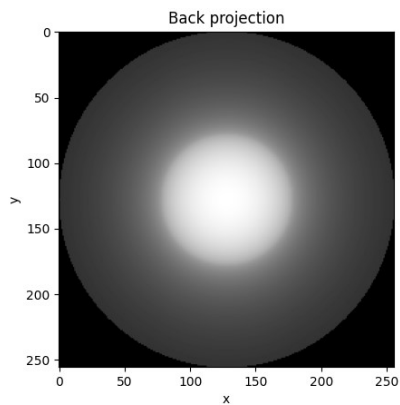
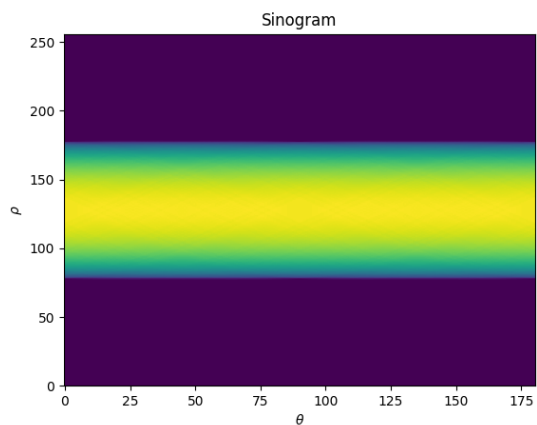

Small Stretched Wire Bench

- **Basic design parameters**
 - *Small size convenient to transport.*
 - *Control by Raspberry Pi (SBC)*
 - *Routines written in Python for ease of use*
 - *Keithley Nanovolt 2182A meter*
 - *Stationary single wire loop*
 - Sample is moving

Stretched Wire Bench - Construction

- **Fixed single strand wire loop**
- **Linear translation stage**
- **Rotary stage**

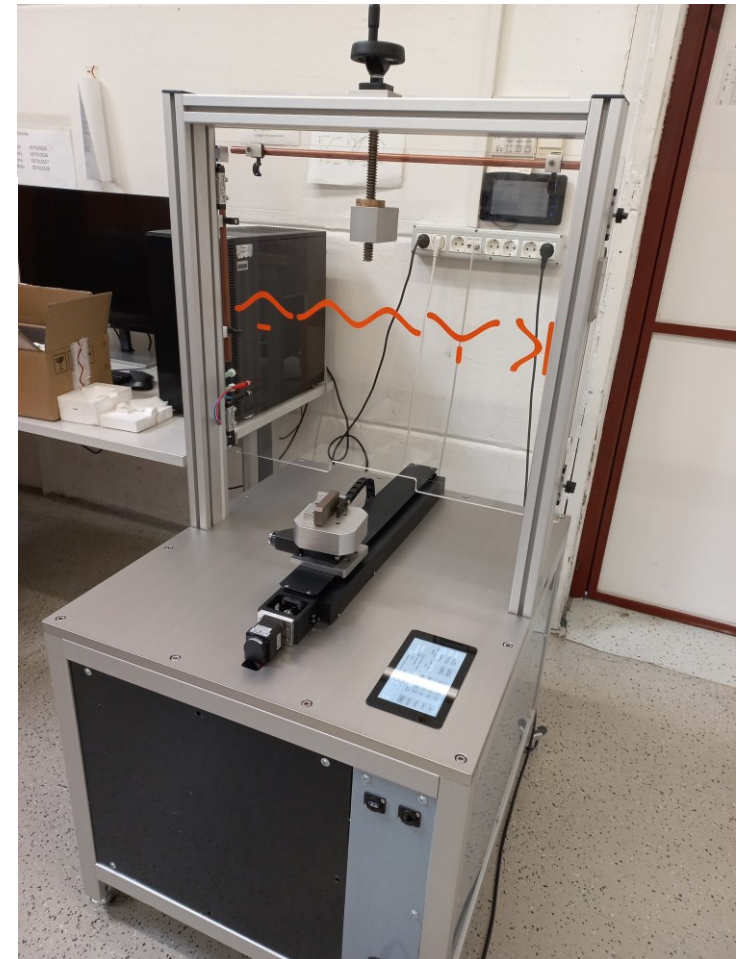
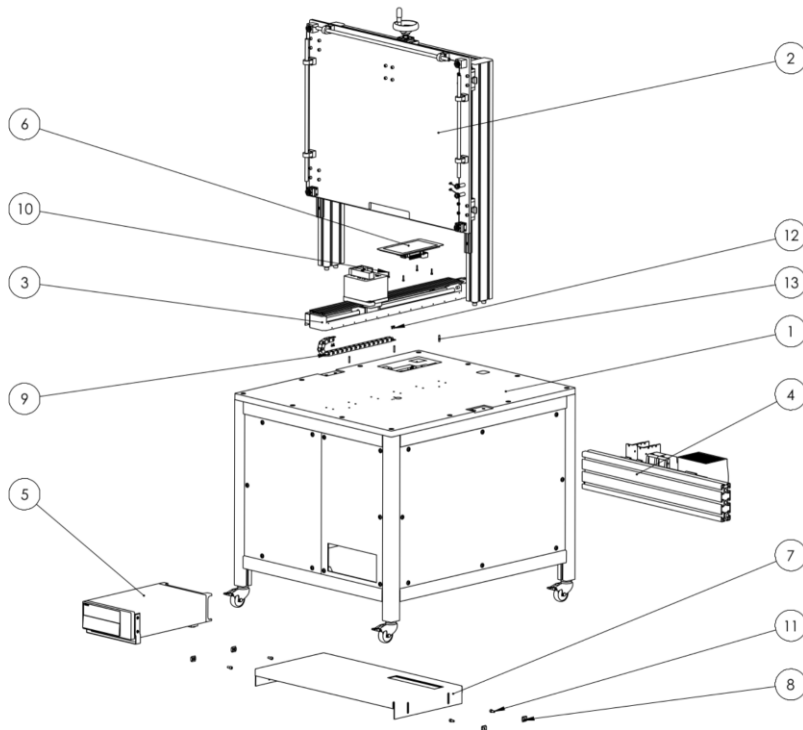

First Measurements

- **A set of 4 cylindrical magnets was used for the first measurements.**

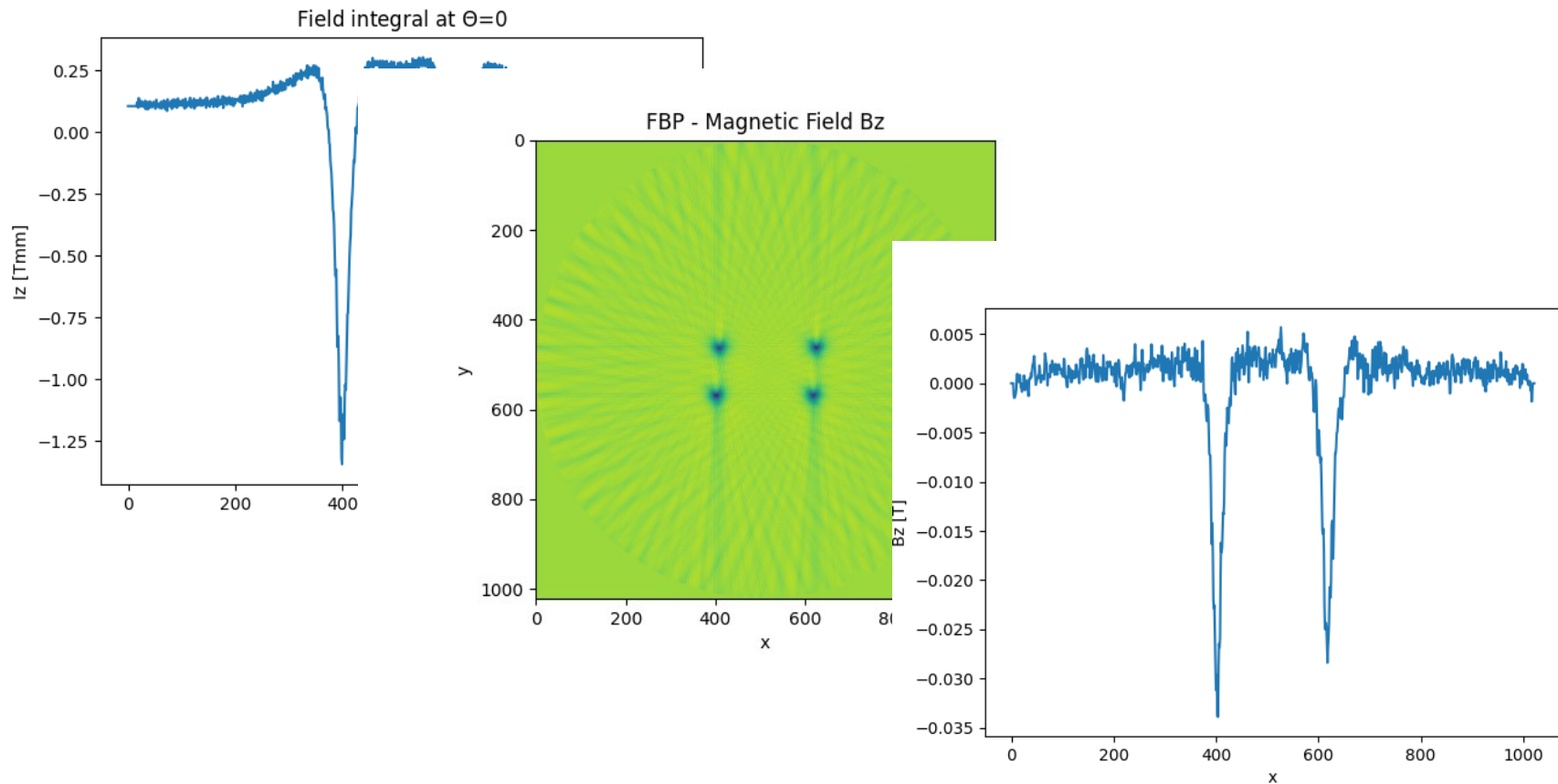

Measurements of a magnet block

- A segmented magnet block made from 3 glued pieces was used for tests.

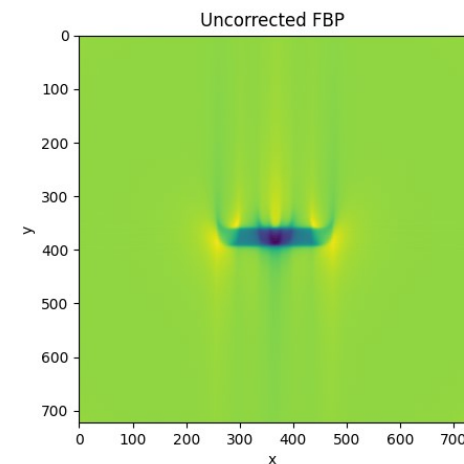
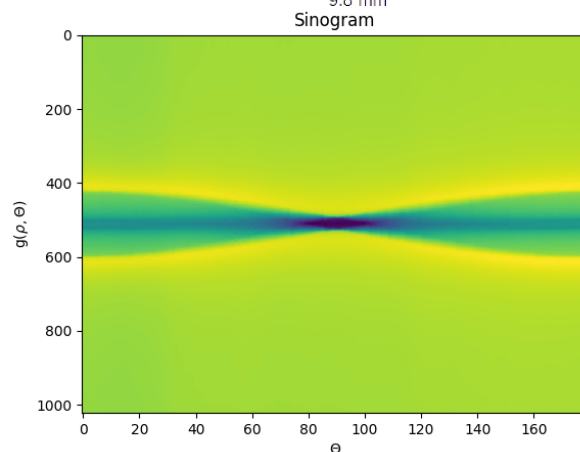
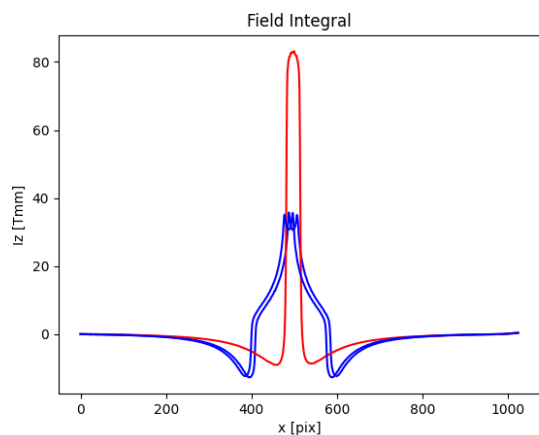
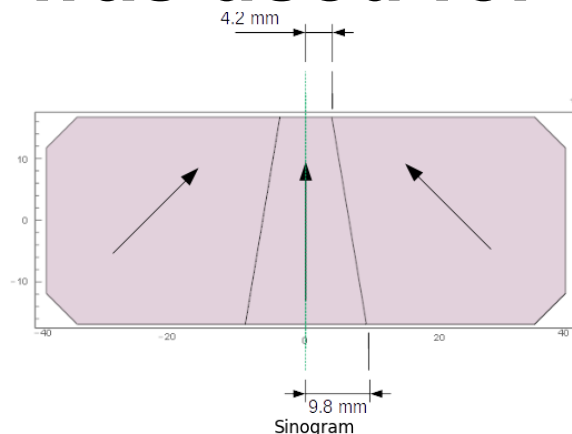

Axis shift correction

- Each point in an image follows a sinus curve on a sinogram.
- Misalignment of the rotation axis can be corrected by removing a sinus fit from a sinogram.

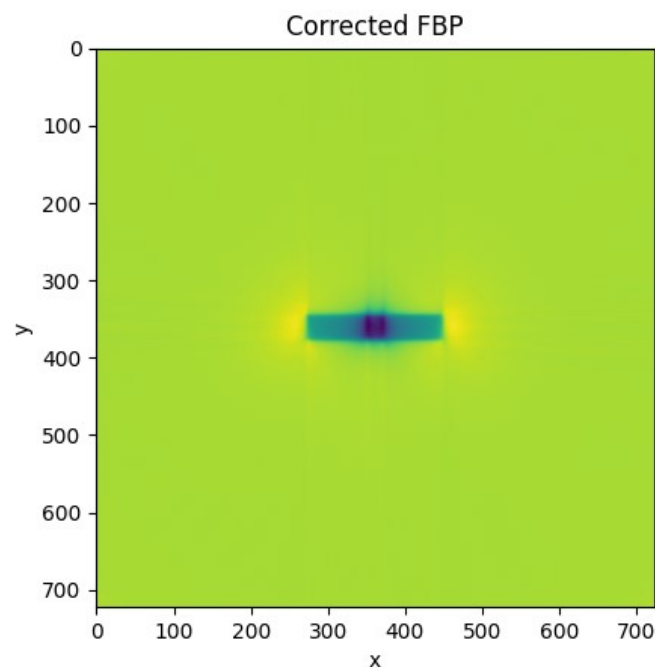
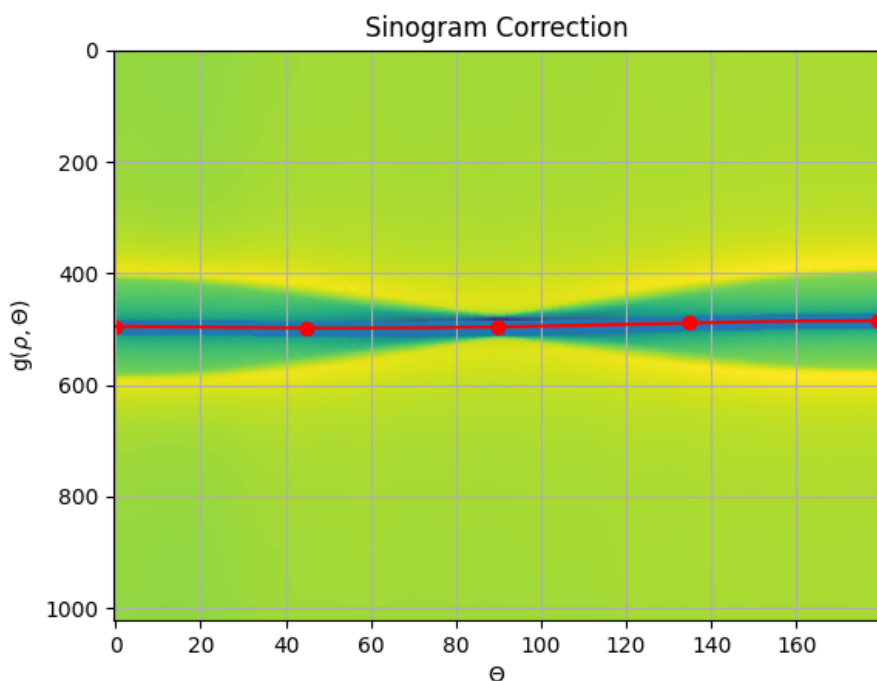

Comparison with a Hall probe

- **2D Hall probe field map**
 - *Distance from surface 1.5 mm*
 - *Longitudinal and horizontal step 0.5 mm/point*
 - *128 x 128 point field map was created*
- **SW Tomography**
 - *Distance from surface was ~ 0.5 mm*
 - *Field integrals measured at 180 angles*
 - *Horizontal step was 0.4 mm/point*

Hall probe

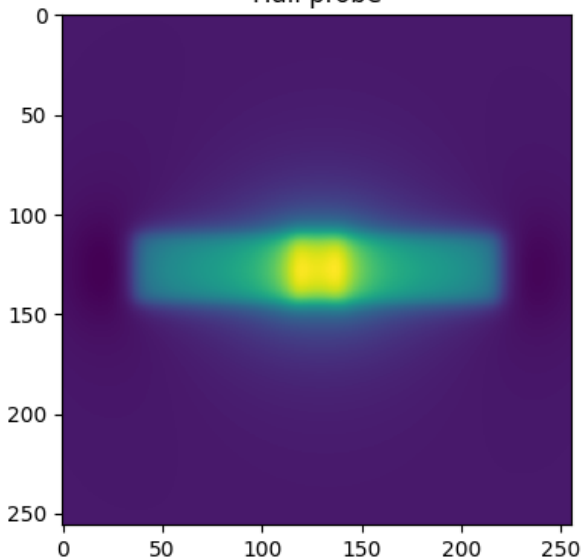

CT Back projection

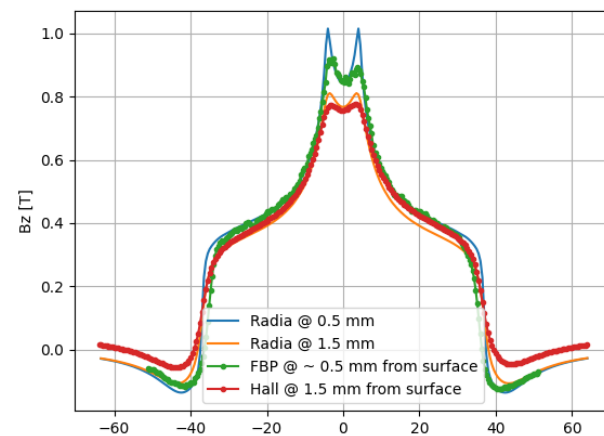
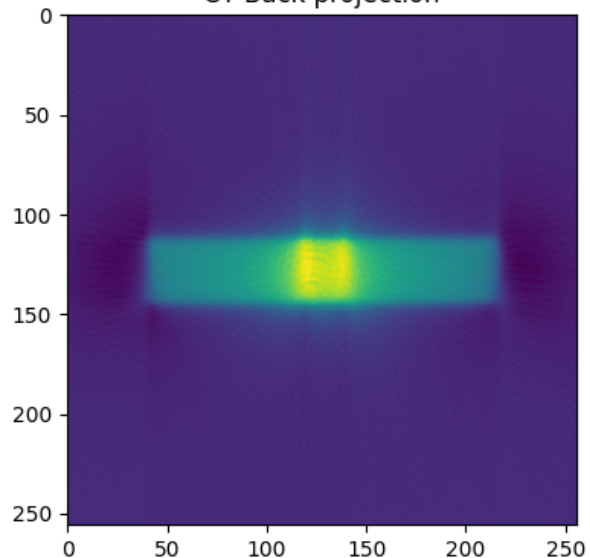

Conclusions

- **A dedicated SW Tomography bench was designed and assembled**
- **First tests are very promising.**
- **Advantages:**
 - *Magnetic field very close to the surface can be measured.*
 - *A dedicated bench can be used for magnet quality control*
 - *Data could be used for further optimizations*
- **Open questions:**
 - *Can we measure absolute values of magnetic field?*

Thanks to the Team!

Special thanks to Andrej Nabergoj and Žan Mahnič

