

# CURSO INTRODUTÓRIO



23 DE JANEIRO  
A 8 DE MARÇO  
DE 2023

FLUKA

FLUKA

FLUKA

FLUKA

FLUKA

# AULA 14

# Campos eletromagnéticos

Iniciaremos em breve

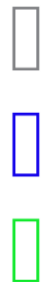
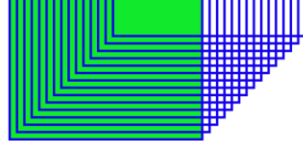

Código Monte Carlo de interação e transporte de partículas



01

02

03

04

05

06

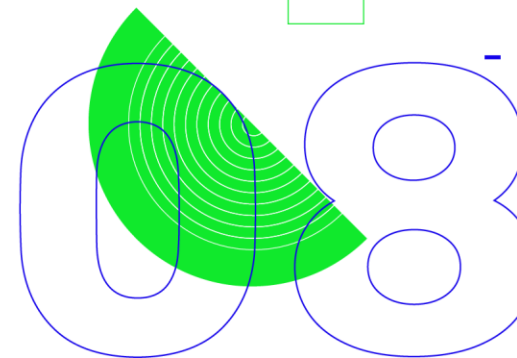
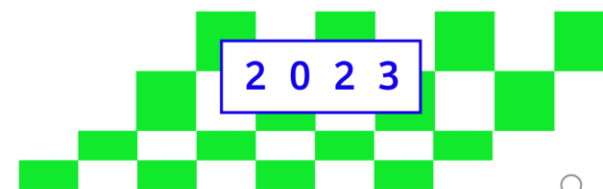

01

02

03

04

05

06

# Introduction

- Magnetic and/or electric fields are crucial for many simulation problems
  - Accelerator magnets, transfer line magnets, solenoids, spectrometers, magnetic horns, ...

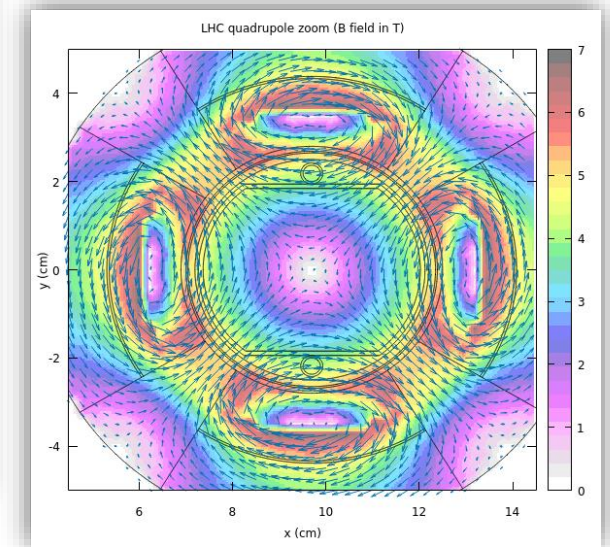
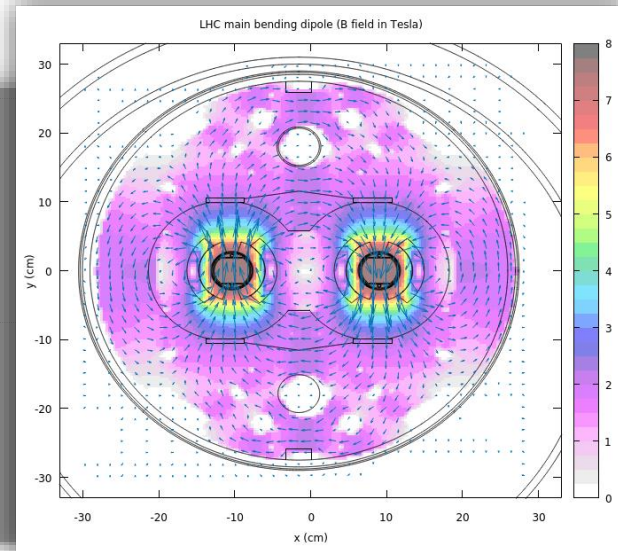
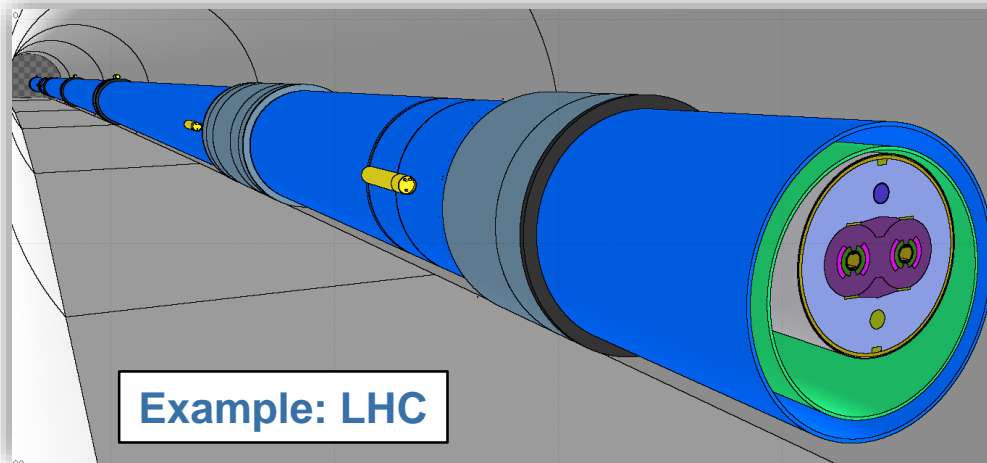

- FLUKA supports the transport of charged particles in *arbitrary* static B and E fields (the latter since FLUKA 4-0.0)
  - This lecture gives a basic introduction how to define fields and presents the relevant transport parameters

# Magnetic and electric fields in FLUKA

- Fields are activated on a per-region basis
  - **Magnetic fields** can be defined **in any region** (filled with any material)
  - **Electric fields** can presently be defined **only in vacuum regions**
  - A region can contain **only one type of field** (magnetic or electric)
- How to define magnetic or electric fields
  - Common (e.g. dipole up to decapole) fields can directly be defined in the **input file** using the **ELCFIELD**, **MGNFIELD** and **MGNCREATE** cards defining the type of field as well as field strength, region association, symmetry, ...
- Transport settings
  - **Particle transport** in the presence of fields entails **some approximations** (true trajectory is decomposed in small straight-line steps)
  - Attention has to be paid to choose adequate transport settings according to your application

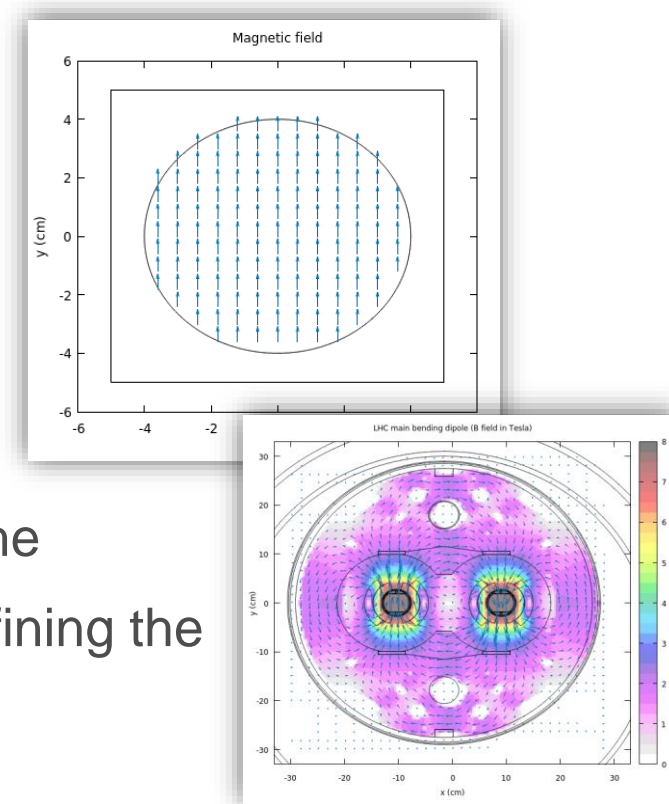

# The relevant cards

- Fields need to be activated in the respective regions using the **ASSIGNMA** card
- The field components can be specified different ways:
  - a) For homogeneous fields: using the **MGNFIELD** or **ELCFIELD** cards\*
  - b) For common magnetic analytical fields and field maps: using **MGNFIELD** in combination with **MGNCREATE** (+ **MGNDATA** for interpolated fields)
  - c) For arbitrary fields: using dedicated user routines (see `src/user/magfld.f` and `src/user/elcfld.f`) if more complex fields need to be implemented
- The transport settings for particles moving in a field can be defined as follows:
  - Globally for all regions via the **MGNFIELD** or **ELCFIELD** cards.
  - On a region-by-region basis via the **STEPSIZE** card (overwrites global settings for these regions).

\* in that case the defined magnetic or electric field is applied in all regions where magnetic or electric fields have been activated via **ASSIGNMA**)

# The relevant cards: common fields

- For common fields, the **MGNFIELD** card is used
  - to set the field **strength**
  - to apply a **transformation** or associate the field to a **region** (or several) or to a **lattice**
- In combination with the **MGNFIELD** card, the **MGNCREATE** card defines
  - the field **type**, which can be
    - **analytical**: constant, dipole, quadrupole, ...
    - **interpolated**: in 2D or 3D field } or a **combination** of both
  - the **radius** of the core region where an analytical field is defined
  - grid parameters for the interpolated field (in combination with **MGNDATA**)
  - (mirror symmetries if applicable)

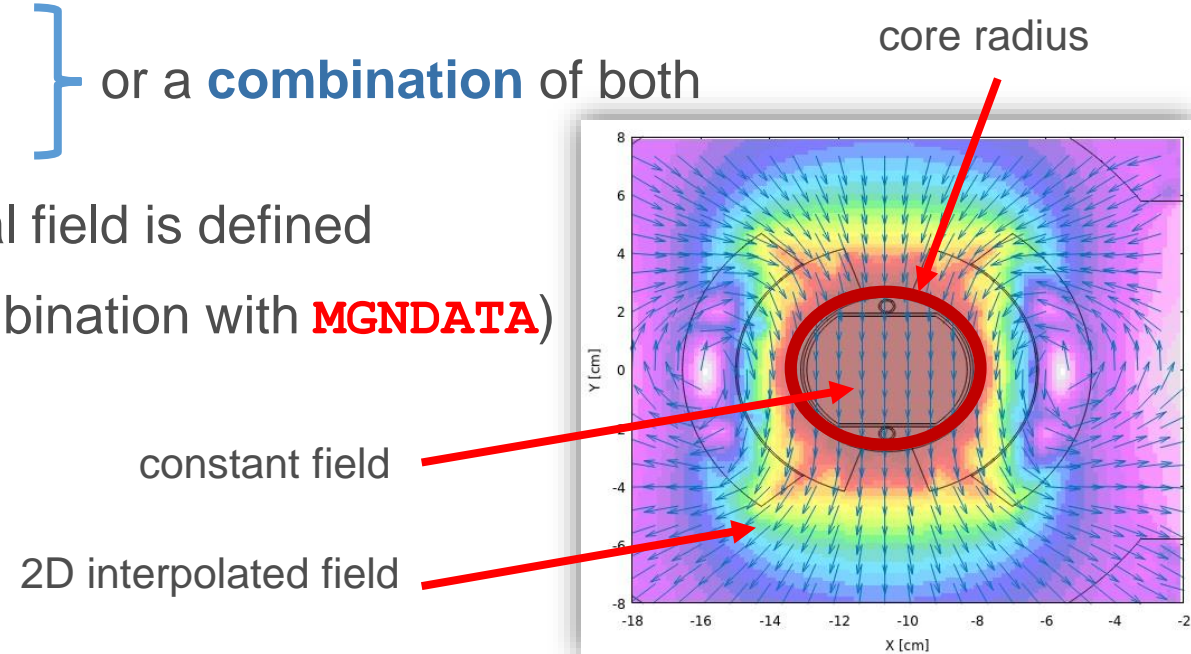

# Activating a field inside a region

Select the **Media** folder

For electric fields, the material must be **VACUUM**

Fields are activated on the **ASSIGNMA** card (under the option “**Field**”)

Use the drop-down list to activate an electric **or** magnetic field in all regions listed on **ASSIGNMA**

- *The option to activate both types of fields in the same region is shown in Flair but is presently not implemented in FLUKA*
- The first two options activate a magnetic or electric field both for prompt and decay radiation
- One can however also selectively switch on a field for either of the two (prompt or decay)

# Setting the components of a homogeneous E field

Select the **Transport** folder

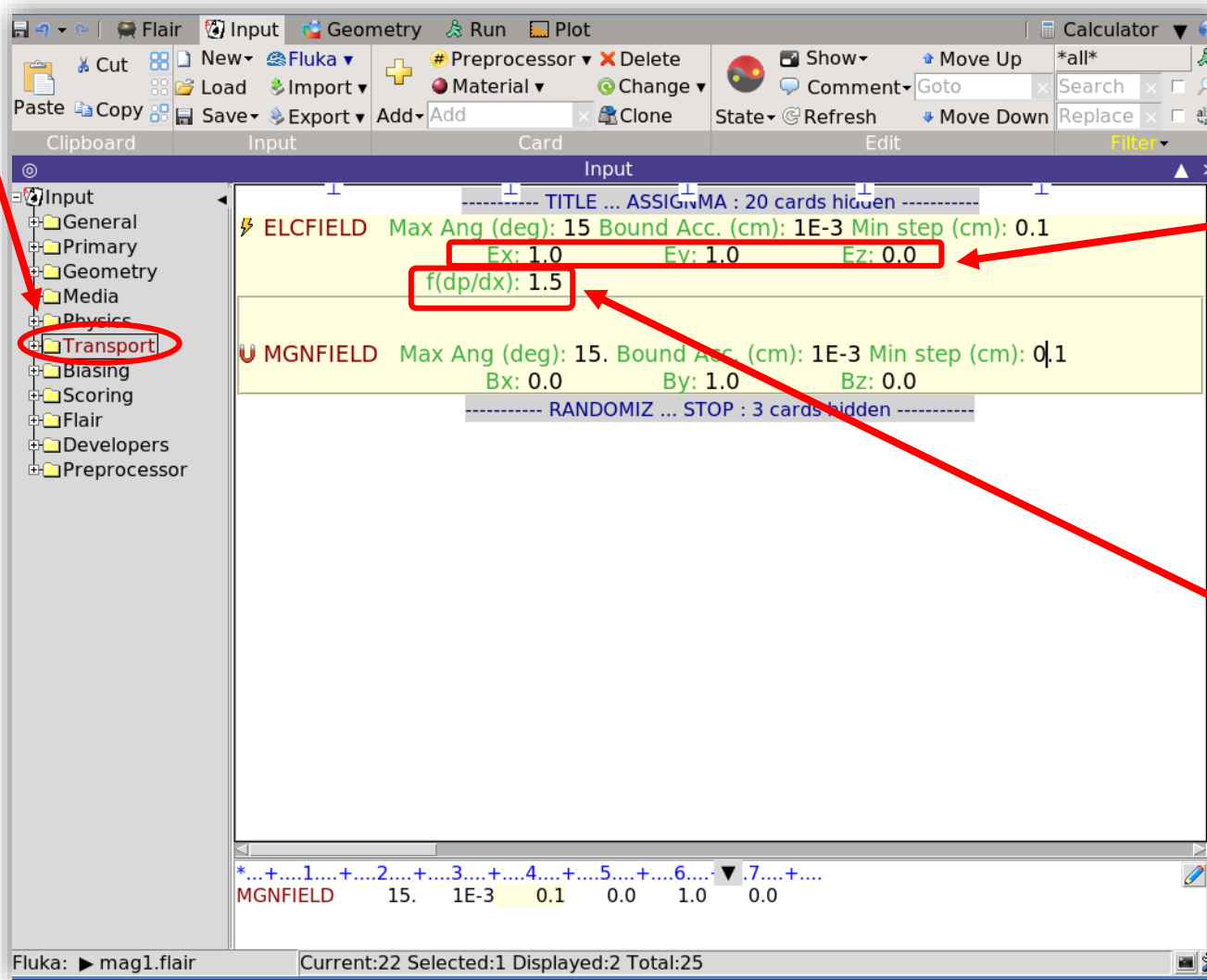

The Cartesian components of a uniform *electric* field can be set on the **ELCFIELD** card (variables Ex, Ey, Ez)  
Units: **kV/cm**

In case no values are specified (or all components are set to zero) a user-defined routine is expected to deliver the values.

In general, cross section tables are created up to the beam energy (BEAM card).

However, charged particles travelling in electric fields can gain energy: this can result in the special case that particles reach higher energies than the beam energy.

**f(dp/dx)** is a factor to extend the upper dp/dx tabulation for charged particles.

# Setting the components of a homogeneous B field

Select the **Transport** folder

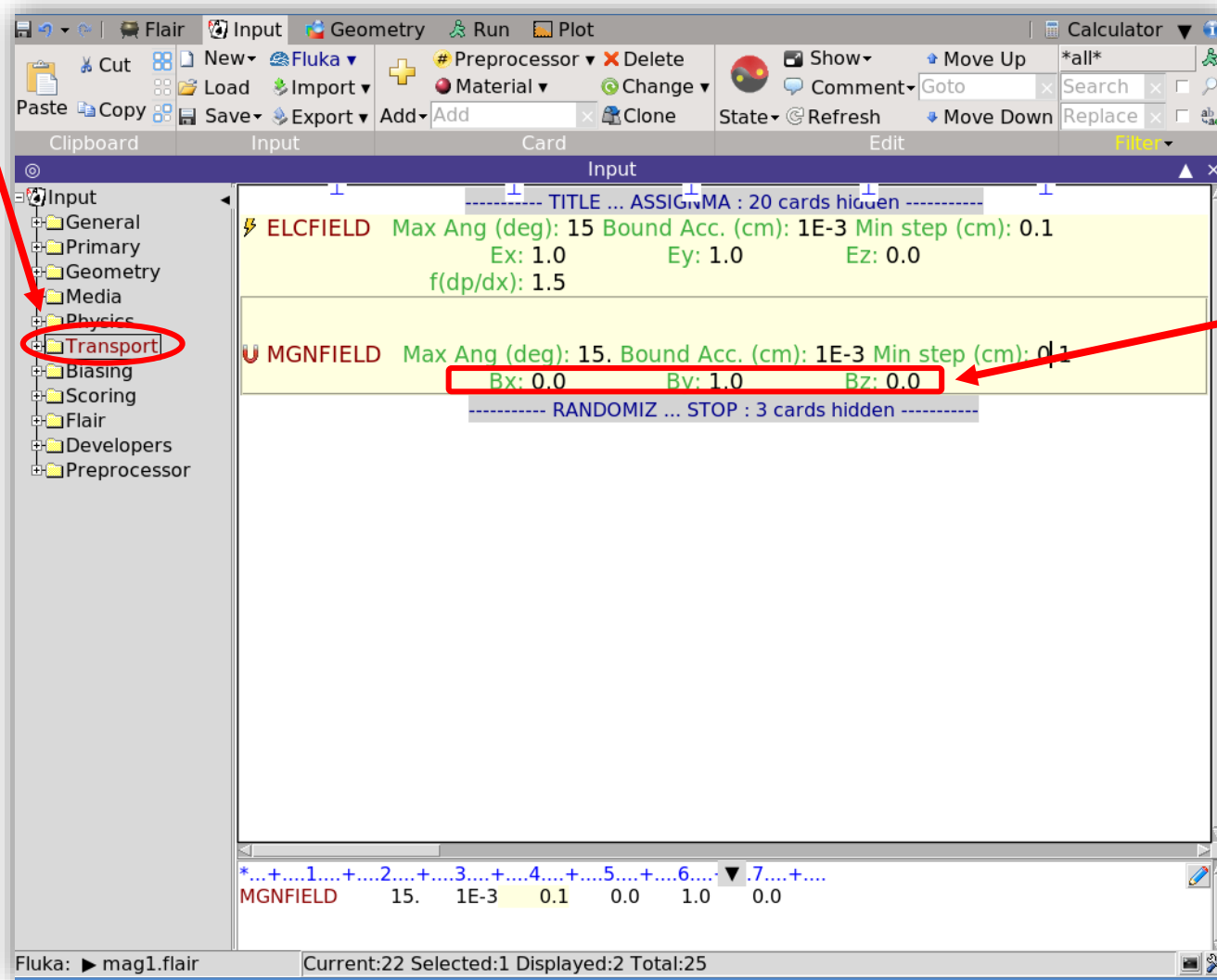

**SDUM = BLANK**

The Cartesian components of a uniform *magnetic* field can be set on the **MGNFIELD** card (variables Bx, By, Bz)  
Units: **Tesla**

In case no values are specified (or all components are set to zero) a user-defined routine is expected to deliver the values.

# Plotting the field

Step 2: add a **Geometry** plot

Step 1: select the **Plot** tab

Step 4: select **Field** (or **Field Vector**, or **Field Intensity**)

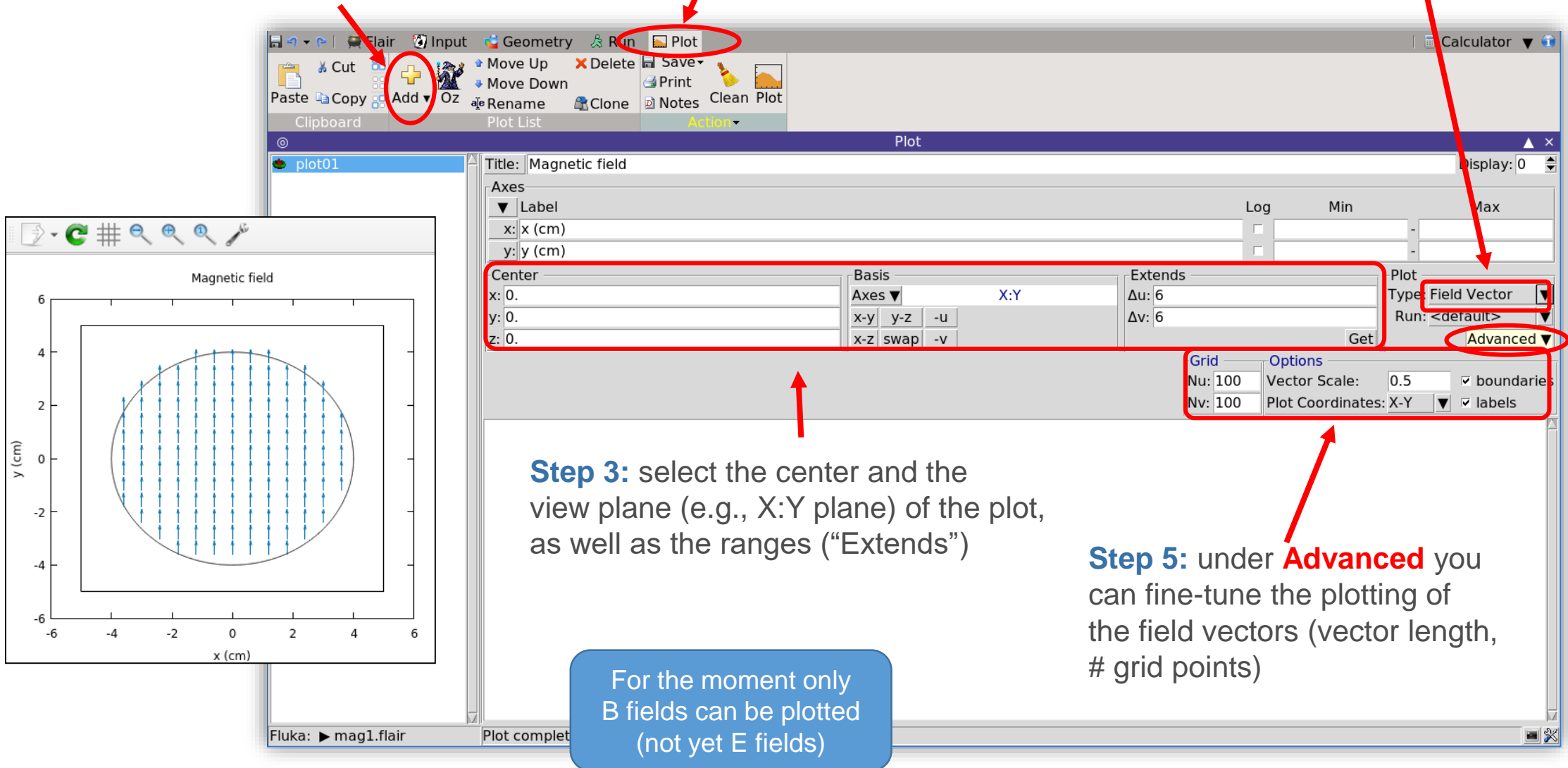

Step 3: select the center and the view plane (e.g., X:Y plane) of the plot, as well as the ranges ("Extends")

Step 5: under **Advanced** you can fine-tune the plotting of the field vectors (vector length, # grid points)

For the moment only B fields can be plotted (not yet E fields)

# Setting the components of a common B field

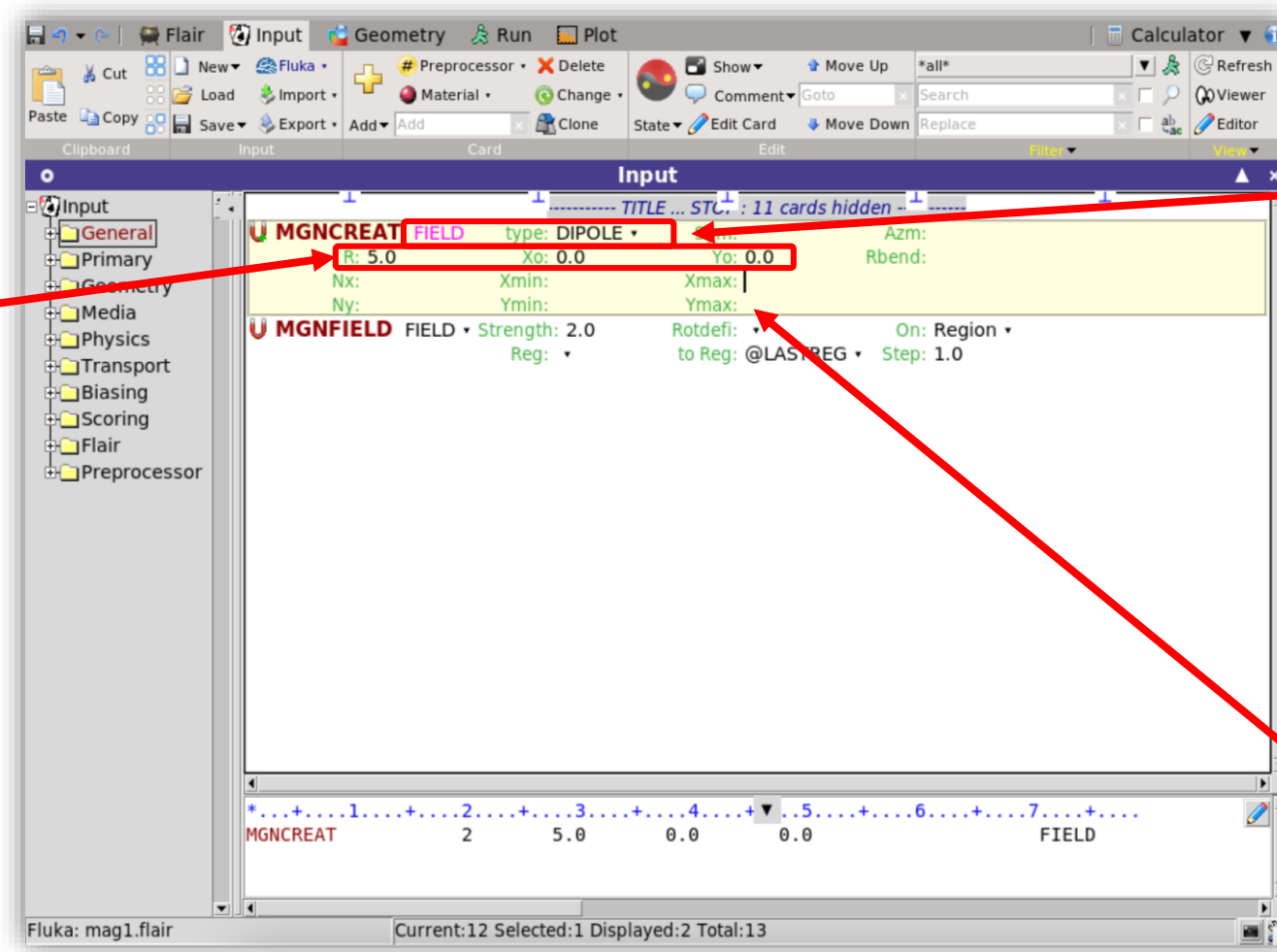

Core radius of analytical field and center offset in X and Y

**MGNCREAT**e: creation of a **dipole** field called "Field". Other options are:

- Constant
- Multipole (quadrupole up to decapole)
- RZ (cylindrical)
- 2D interpolated field
- 2D + analytical field
- 3D interpolated field
- 3D + analytical field

Grid parameters for interpolated field (using **MGNDATA** cards) in case it is used

(Not shown: symmetry options)

# MGNCREATE

Distribuições de multipolo com cartão MGNCREATE

## Quadrupolo

Magnetic field in x-y plane

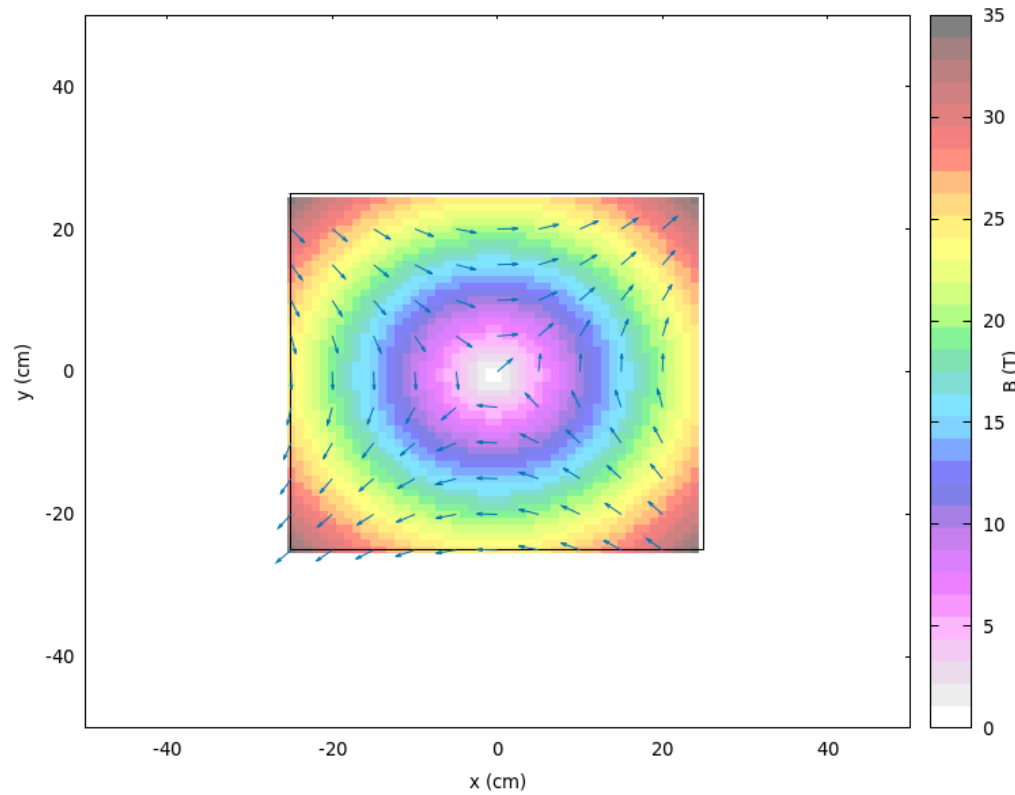

## Sextupolo

Magnetic field in x-y plane

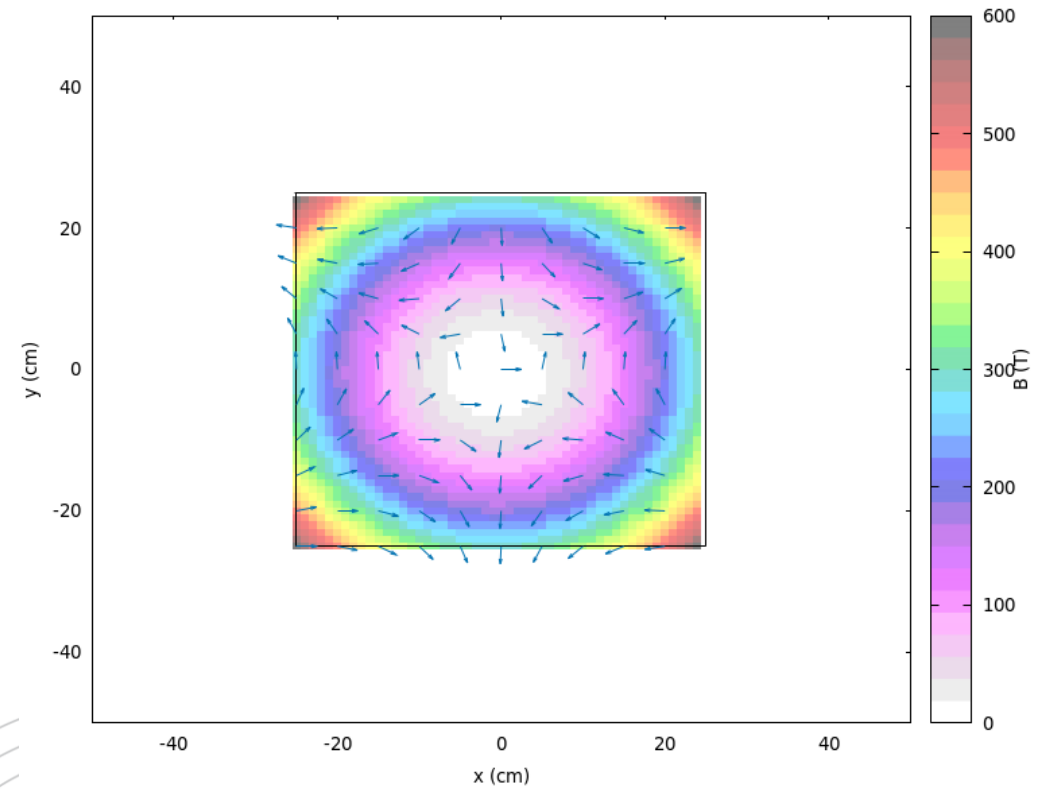

# Setting the components of a common B field

SDUM entry links to right **MGNCREATe** card

The screenshot shows the Fluka input editor interface. The main window displays the 'Input' card editor with a tree view on the left. The 'Input' card is expanded, showing two cards: 'MGNCREAT FIELD' and 'MGNFIELD FIELD'. The 'MGNFIELD' card is highlighted in yellow and contains the following parameters: Strength: 2.0, Rotdefi: (dropdown), to Reg: @LASTREG, On: Region (dropdown), and Step: 1.0. A red circle highlights the 'Rotdefi' and 'to Reg' fields. A red arrow points from the 'SDUM' entry in the 'MGNFIELD' card to the 'MGNCREAT' card. Another red arrow points from the 'Strength' field to a text box below the card.

Depending on the field type, this specifies field strength or gradient (in T, T/m T/m<sup>2</sup>, ...)

**SDUM** = field name defined by **MGNCREATe** card

**MGNFIELD** card associates a specific magnetic field on a **region-by-region** basis OR with a **lattice** cell through a **ROTDEFI** which maps either prototype or container coordinates on magnetic field system coordinates.

Regions are automatically flagged as magnetic (no need for **ASSIGNMAT** card)

# MGNCREATE

Distribuições arbitrárias de campo com cartões MGNCREATE e MGNDATA

MGNCREATE: Definições do tipo de distribuição de campo e disposição de pontos na malha

MGNDATA: Campo por ponto da malha

<b>ASSIGNMAT</b>	Mat: COPPER ▾	Reg: TARGET ▾	to Reg: ▾
<b>MGNCREATE CAMPO</b>	Mat(Decay): ▾	Step: 0	Field: Magnetic ▾
Nx: 2	type: 2D ▾	Sym: 0	
Ny: 2	Xmin: -5	Xmax: 5	
<b>MGNFIELD CAMPO ▾</b>	Strength: 0.01	Rotdefi: ▾	On: Region ▾
<b>MGNDATA CAMPO ▾</b>	Reg: TARGET ▾	to Reg: TARGET ▾	Step: 1.0
	Bx: 0	By: 1	Bz: 0

```
define data for interpolated magnetic field type
*...+...1...+...2...+...3...+...4...+...5...+...6...+...7...+...
MGNDATA      0      1      0      5      0.0      10CAMPO
MGNDATA      0.0    10      &
```

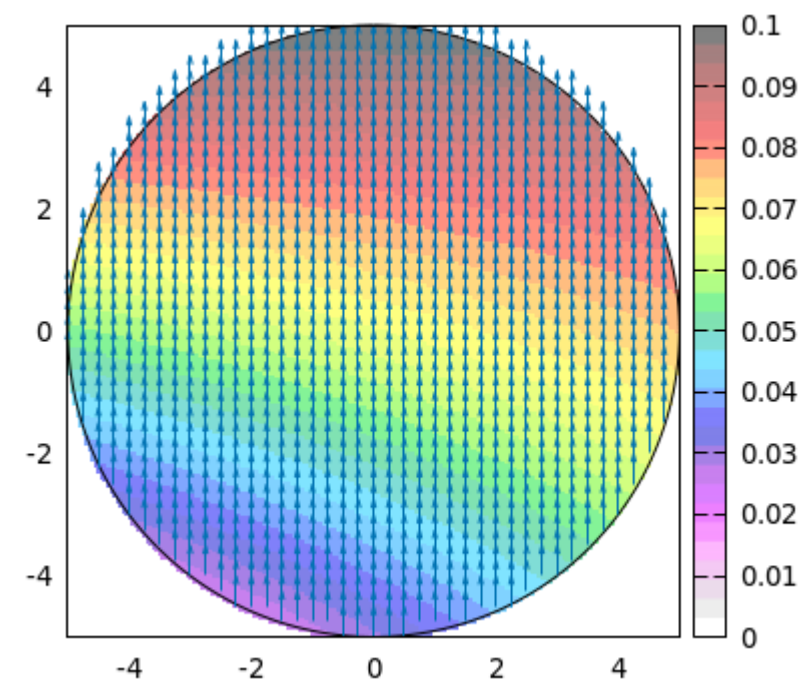

# MGNCREATE

Cuidado: é necessário incluir mais pontos clicando com o botão direito em cima do cartão MGNDATA, escolhendo a opção “edit card” para modo 2D.

**ASSIGNMAT** Mat: COPPER ▼ Reg: TARGET ▼ to Reg: ▼  
MGNCREATE CAMPO Mat(Decay): ▼ type: 2D ▼ Step: 0 Field: Magnetic ▼  
Nx: 2 Xmin: -5 Xmax: 5  
Ny: 2 Ymin: -5 Ymax: 5  
MGNFIELD CAMPO ▼ Strength: 0.01 Rotdefl: ▼ On: Region ▼  
Reg: TARGET ▼ to Reg: TARGET ▼ Step: 1.0  
MGNDATA CAMPO ▼ Bx: 0 By: 1 Bz: 0

```
define data for interpolated magnetic field type  
*...+...1...+...2...+...3...+...4...+...5...+...6...+...7...+...  
MGNDATA 0 1 0 5 0.0 10 CAMPO  
MGNDATA 0.0 10 &
```

**Edit Card**

Comment:

Card: MGNDATA Lines: 2 name: CAMPO

1: 0	2: 1	3: 0
4: 5	5: 0.0	6: 10
2-1: 0.0	2-2: 10	2-3:
2-4:	2-5:	2-6:

Text:

Properties:

Ok Cancel Help

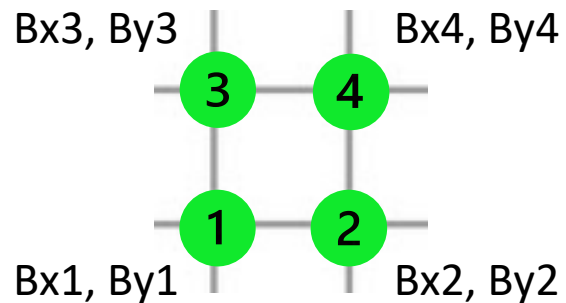

# Setting the components of a common B field

To use interpolated maps the type can be set to include "2D" or "3D"

The screenshot shows the FLUKA input editor with the following cards:

```

MGNCREAT FIELD Type: 2D+DIPOLE Sym: Azm:
R: 5.0 Xo: 0.0 Yo: 0.0 Rbend:
Nx: Xmin: Xmax:
Ny: Ymin: Ymax:
MGNFIELD FIELD Strength: 2.0 Rotdef: On: Region
Reg: to Reg: @LASTREG Step: 1.0
MGNDATA FIELD Bx: 0.0 By: 2.0 Bz: 0.0
MGNDATA FIELD Bx: 0.0 By: 2.0 Bz: 0.0
MGNDATA FIELD Bx: 0.0 By: 2.0 Bz: 0.0
    
```

Annotations in the image include:

- A red circle around "2D+DIPOLE" with an arrow pointing to the text: "Link to the magnetic field defined using **MGNCREAT**e".
- A red circle around the first "MGNDATA" card with an arrow pointing to the text: "One **MGNDATA** card to define each grid point in sequence (in this example a constant field along Y-axis)".

At the bottom of the editor, a table shows the values for the selected card:

MGNDATA	FIELD	0.0	2.0	0.0	FIELD

**MGNDATA** cards allow the user to input the values of the field in the interpolation grid described via the **MGNCREAT**e card. One such card should be provided per grid point in the order as shown below, to describe more complex fields\*:

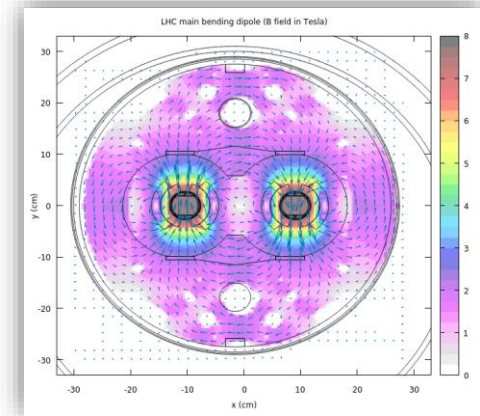
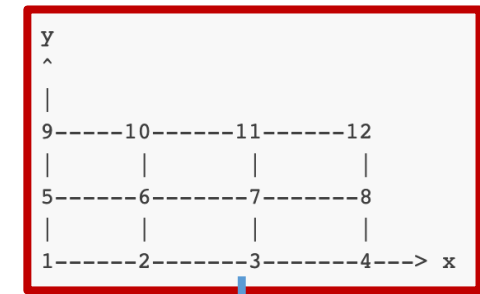

\* For RZ interpolation, same as above replacing  $X \leftrightarrow R$  and  $Y \leftrightarrow Z$ , for 3D interpolation, same as for 2D plane by plane for each Z slice.

# Remarks concerning the tracking in fields

- When tracking in magnetic fields, FLUKA accounts for:
  - The **precession of the MCS\* final direction** around the particle direction: this is critical in order to preserve the various correlations embedded in the FLUKA MCS algorithm
  - The **decrease of the particle momentum** due to energy losses along a given step and hence the corresponding **decrease of its curvature radius**.
  - The **precession of a (possible) particle polarization** around its direction of motion: this matters only when polarization of charged particles is an issue (mostly for muons in Fluka)
- When tracking in electric fields inside vacuum, FLUKA accounts for:
  - The **change of the projectile energy** due to the electric field itself

\*Multiple Coulomb Scattering

# Transport settings

- The true trajectory of a charged particle inside a field (black) is approximated by linear steps (red)
  - The end point will always be on the true path, but generally not exactly on the region boundary
  - An iteration is performed until a certain boundary crossing accuracy is achieved
- The tracking accuracy can be tuned by the user:
  - The maximum angle ( $\alpha$  - in deg) subtended by a single step from the origin of the curved path.
  - The maximum permissible error ( $\epsilon$  in cm) in geometry intersections.
- Note:
  - Both conditions ( $\alpha$  and  $\epsilon$ ) are fulfilled during tracking
  - If  $\alpha$  and/or  $\epsilon$  are too large, then geometry boundaries can be missed
  - If they are too small, then the CPU time can increase a lot

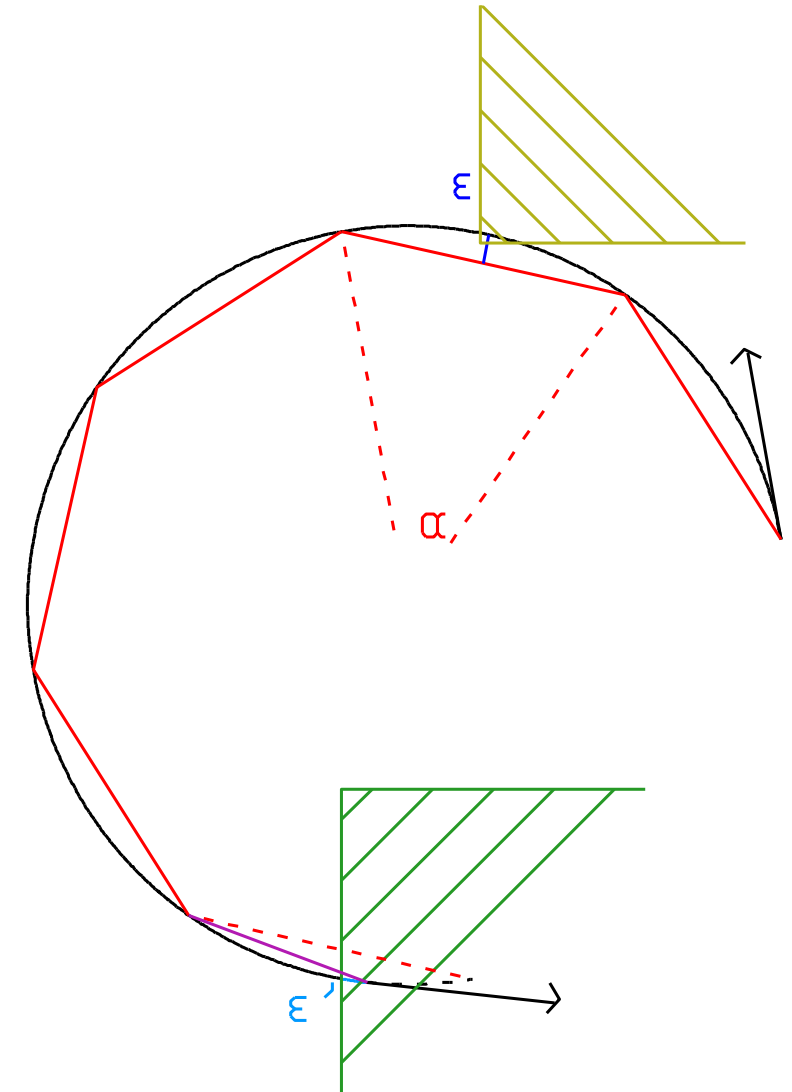

# Global transport settings for B (and E) fields

- The transport parameters can be globally set on the **MGNFIELD** (and **ELCFIELD**) cards

Maximum angle  $\alpha$  (in deg)  
(default: 57 deg, max.  
recommended: 30 deg)

Max. error on boundary  
intersection iteration  $\epsilon$  (in cm)  
(default: 0.5 mm!)

```
U MGNFIELD Max Ang (deg): 30 Bound Acc. (cm): 0.001 Min step (cm): 0.1  
Bx: 0.0 By: 1 Bz: 0.0
```

(analogous for ELCFIELD card)

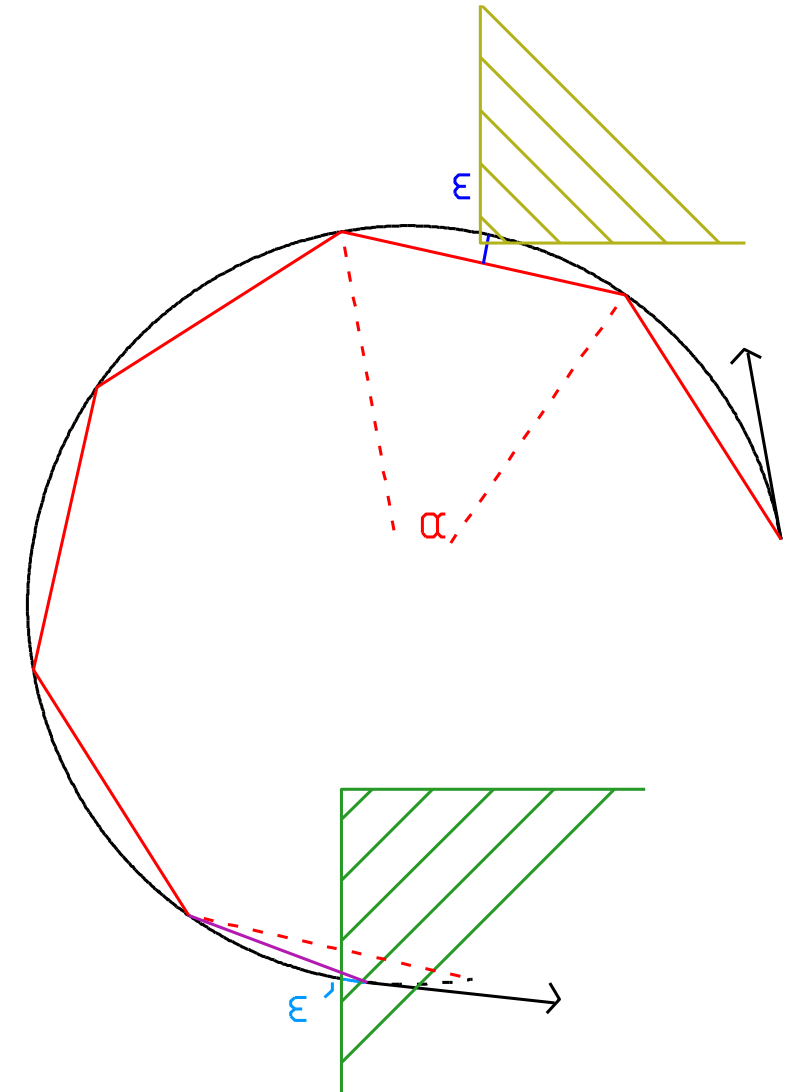

# Beware of default settings (here: $\epsilon$ )

U MGNFIELD Max Ang (deg): Bound Acc. (cm): ← Min step (cm):

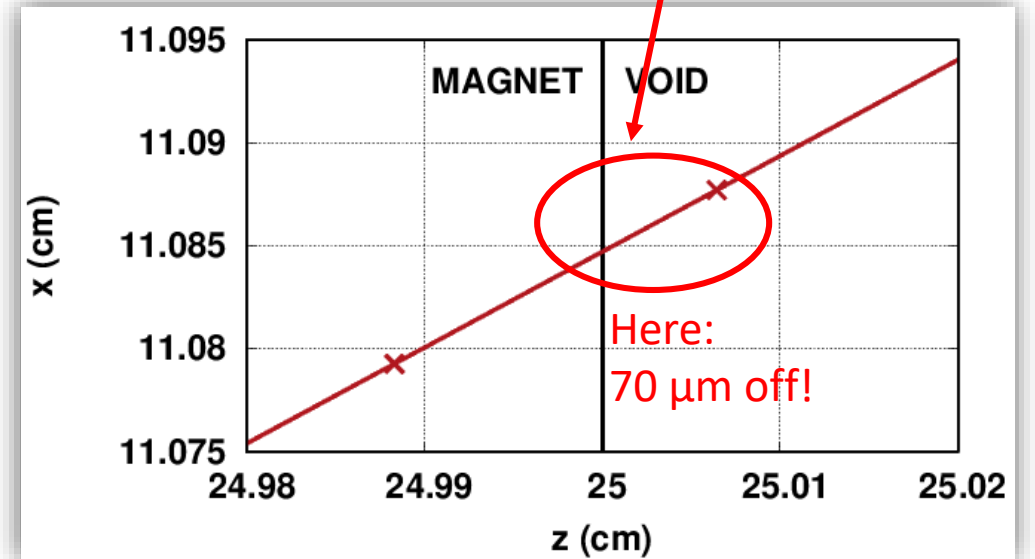
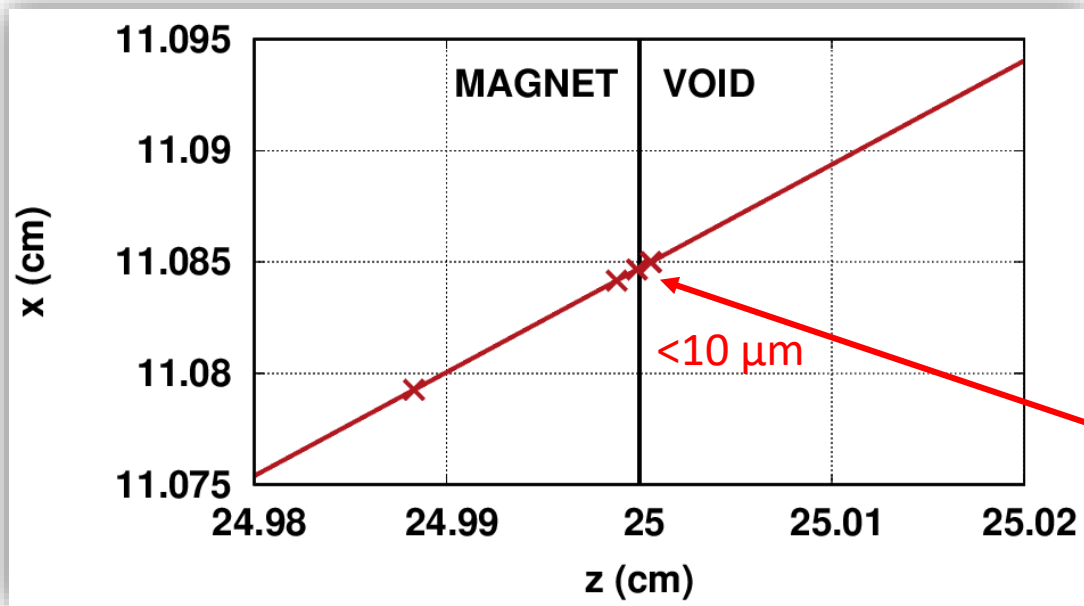

U MGNFIELD Max Ang (deg): Bound Acc. (cm): 0.001 Min step (cm):

Rule of thumb:  $\epsilon$  shall be *smaller than the region dimensions* (be careful in presence of small structures), but watch out for excessive CPU times

# Global transport settings for B (and E) fields (cont.)

- Avoiding too small steps (endless tracking)

In some cases, the settings can lead to very small steps:  
to avoid endless tracking, a minimum sub-step size  $\Delta s$  can be set (default 1 mm);

```
U MGNFIELD Max Ang (deg): 30 Bound Acc. (cm): 0.001 Min step (cm): 0.1  
Bx: 0.0 By: 1 Bz: 0.0
```

(analogous for ELCFIELD card)

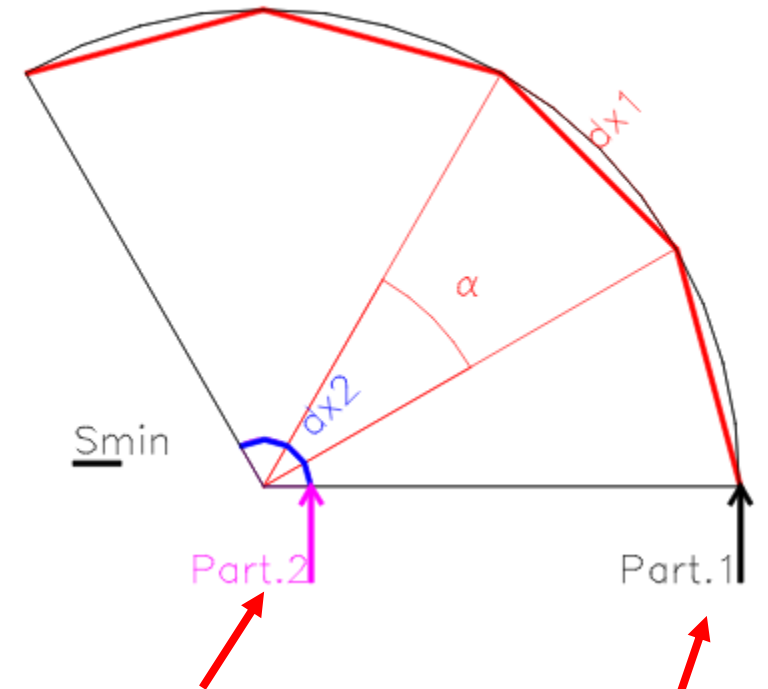

$\alpha$  leads to too small steps ( $< \Delta s$ ):  
Sub-step size increased to  $\Delta s$

$\alpha$  leads to steps  $> \Delta s$ :  
Sub-step size not changed

# Region-by-region transport settings for B/E fields

- The global transport parameters can be overwritten for (selected) regions using the **STEPsize** card
- Region-by-region tuning can save CPU time

If negative value given: abs. value defines the max. error on boundary intersection iteration  $\epsilon$  (in cm) for the given



If positive value given: minimum sub-step size  $\Delta s$

# Outlook (advanced features)

- In the case where the FLUKA magnetic/electric are insufficient, dedicated routines can be used to simulate more complex problems
- Such fields can be described in the **MAGFLD/ELEFLD** routines (`src/user/magfld.f` and `src/user/elcfld.f`)
  - In these routines, the field components and field strength can be defined as a function of the coordinates. Only called in regions declared as magnetic/electric via the relevant **ASSIGNMA** card

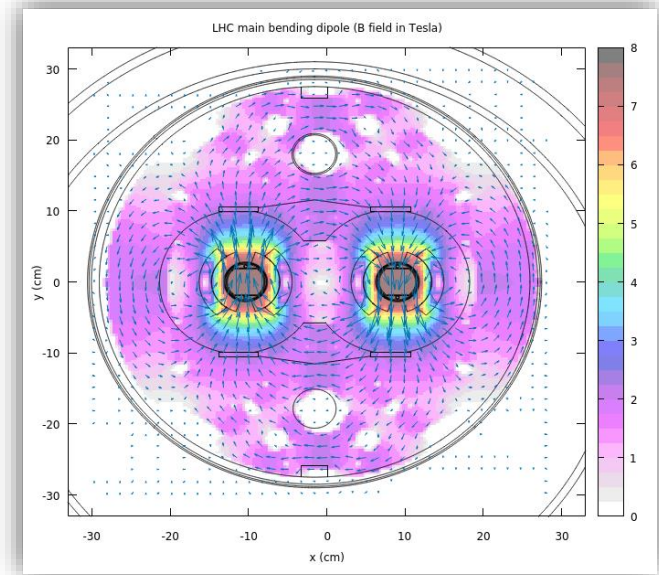



## Exercise: Magnetic Field

Aim of the exercise:

- Define a dipole field which deviates the beam on a target
- Plot the field
- Visualize the effect of the field on the beam trajectory

# Goal of the exercise

- Introduce a dipole field in order to deflect a given beam on a pre-defined target

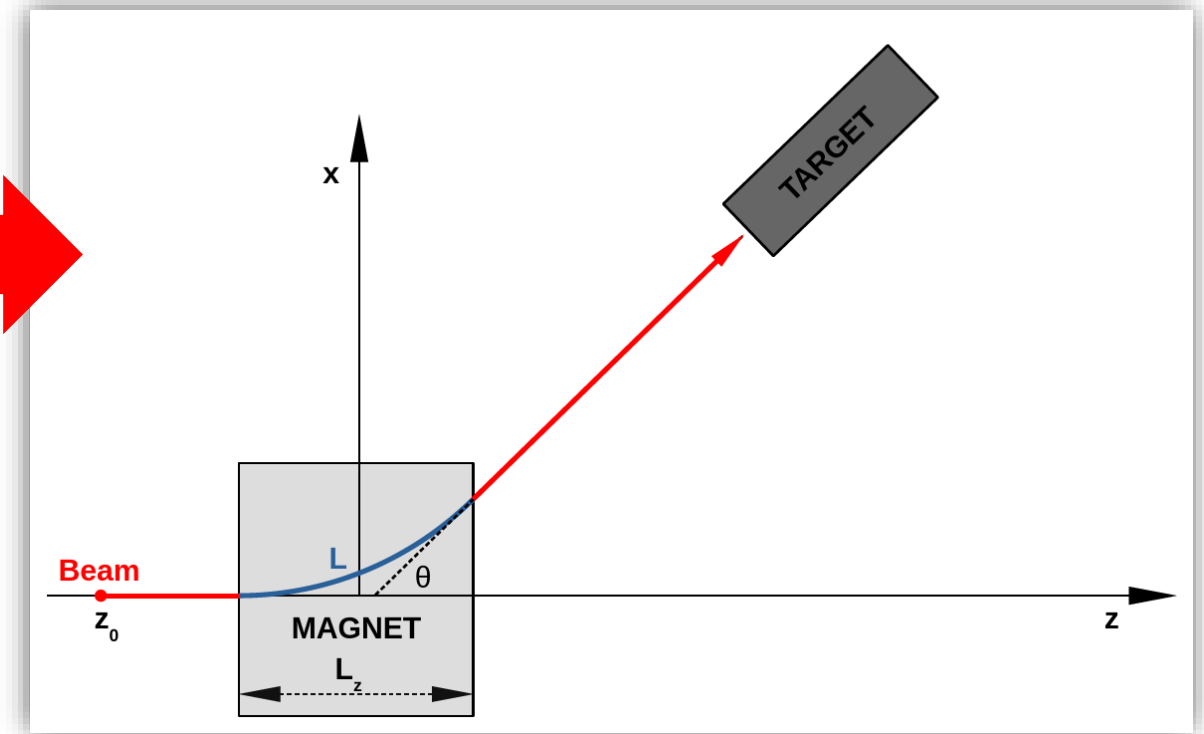
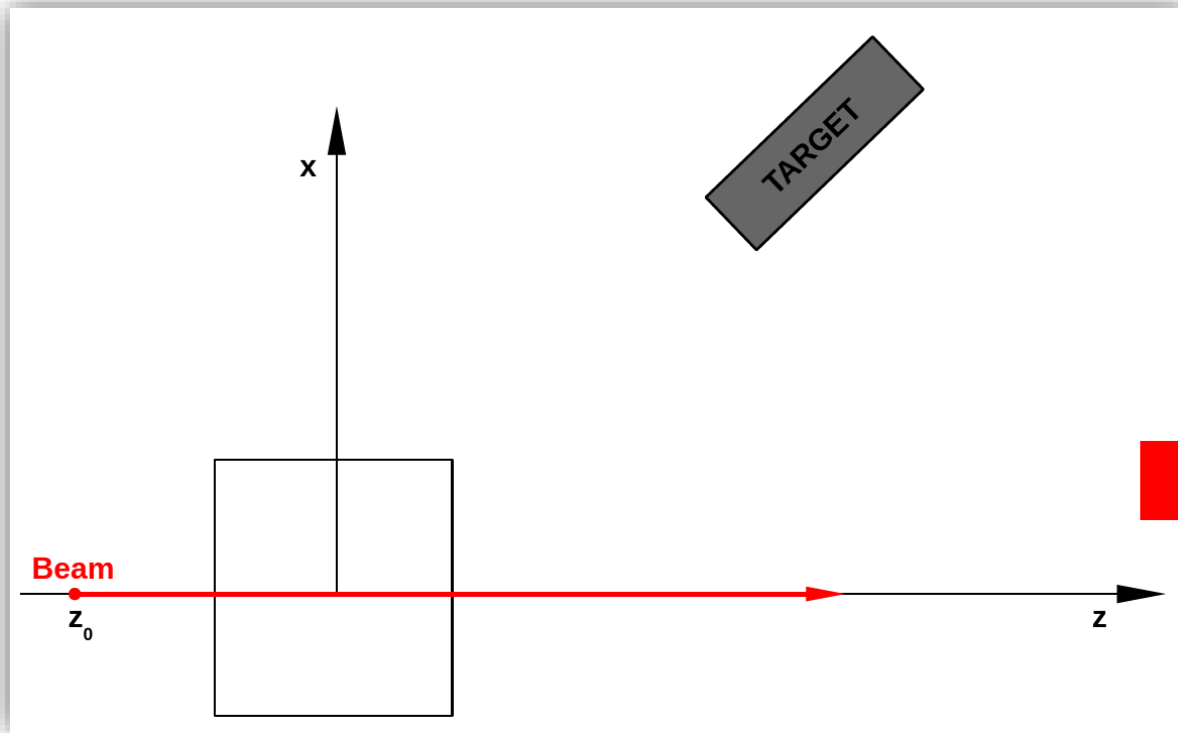

- Proton pencil beam with **600 MeV/c**
- Starts at  $z_0 = -50$  cm, in positive **z-direction**

# Steps

- The beam, regions and scoring is pre-defined
  - Note that all regions except the target are set to VACUUM (including the magnet)

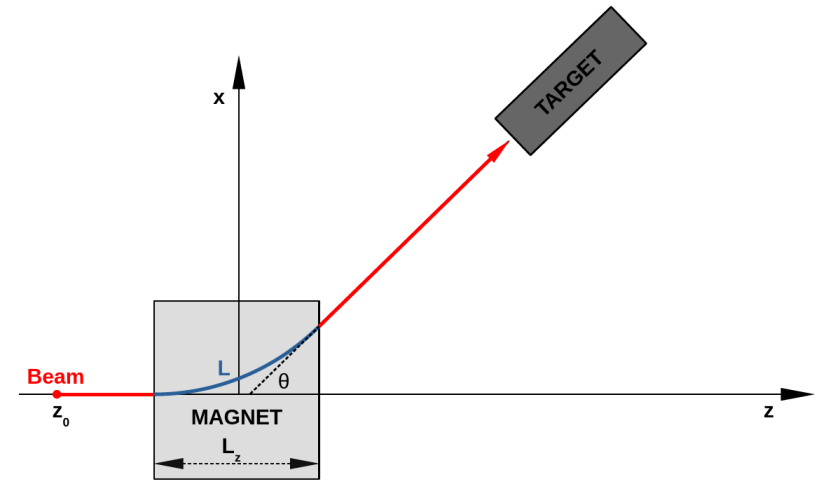

- Exercise steps:

1. Activate a magnetic field in the pre-defined region called **MAGNET** (**ASSIGNMA** card)
2. Introduce a **MGNFIELD** card and define a B field such that:
  - a. the beam is deflected in the **x-z plane** as illustrated in the figure (hint: the B field direction can be determined from the Lorentz force).
  - b. the deflection angle  $\theta$  is **25 deg**; use the formula on slide 5 to determine the required  $|B|$ . Note that the magnet is  **$L_z=50$  cm** long in z-direction.
3. Verify that the field is correctly activated by plotting the field intensity and field vectors:
  - a. see lecture slides for instructions how to plot a field
  - b. make sure to chose an appropriate plotting plane which contains the field vectors
4. Run one cycle (1 primary) and plot the particle fluence in the x-z plane
  - a. use the *pre-defined* **USRBIN** scoring in the Plot tab of Flair

For simplicity, let's keep the default transport settings

Did you manage to hit the target?

# Lorentz force

- Use following expression to determine which B field component needs to be set on the **MGNFIELD** card in order to deflect the beam on the target:

$$\begin{pmatrix} F_x \\ F_y \\ F_z \end{pmatrix} = q \begin{pmatrix} v_x \\ v_y \\ v_z \end{pmatrix} \times \begin{pmatrix} B_x \\ B_y \\ B_z \end{pmatrix} = q \begin{pmatrix} v_y B_z - v_z B_y \\ v_z B_x - v_x B_z \\ v_x B_y - v_y B_x \end{pmatrix}$$

- $(F_x, F_y, F_z)$  = Lorentz force
- $q$  = Particle charge
- $(v_x, v_y, v_z)$  = Particle velocity
- $(B_x, B_y, B_z)$  = Magnetic field (magnetic flux density) components

# Required $|B|$

- Use the following expression to determine the required  $|B|$  in order to deviate the beam on the target:

$$\frac{p \text{ [GeV/c]}}{0.299792 Q \text{ [e]}} = \frac{|B| \text{ [T]} L_z \text{ [m]}}{\sin \theta}$$

- $p$  = Particle momentum in GeV/c
- $Q$  = Particle charge (as multiple of elementary charges)
- $|B| = \sqrt{B_x^2 + B_y^2 + B_z^2}$  in Tesla
- $L_z$  = Length of the magnetic field in z-direction (i.e. in the original beam direction)
- $\theta$  = Deflection angle in rad

Note: this formula can be simply derived from the Lorentz force and applies for a homogenous dipole field with  $L_z < R$ , where  $R$  is the bending radius.



## Exercise: Magnetic Field - Solution

Aim of the exercise:

- Define a dipole field which deviates the beam on a target
- Plot the field
- Visualize the effect of the field on the beam trajectory

# B field direction

- The B field is perpendicular to the plane of movement - hence only  $B_y$  can be non-zero if the particle shall move in the x-z plane:

$$\begin{pmatrix} F_x \\ 0 \\ F_z \end{pmatrix} = q \begin{pmatrix} v_x \\ v_y \\ v_z \end{pmatrix} \times \begin{pmatrix} B_x \\ B_y \\ B_z \end{pmatrix} = q \begin{pmatrix} v_y B_z - v_z B_y \\ v_z B_x - v_x B_z \\ v_x B_y - v_y B_x \end{pmatrix} = q \begin{pmatrix} -v_z B_y \\ 0 \\ v_x B_y \end{pmatrix}$$

- $(F_x, F_y, F_z) =$  Lorentz force
- $q =$  Particle charge
- $(v_x, v_y, v_z) =$  Particle velocity
- $(B_x, B_y, B_z) =$  Magnetic field components
- Protons are positively charged ( $q > 0$ ):
  - As shown in the figure:  $F_x > 0$  and  $F_z \leq 0$
  - Since  $v_z > 0, v_x \geq 0$ ,  $B_y$  must be negative

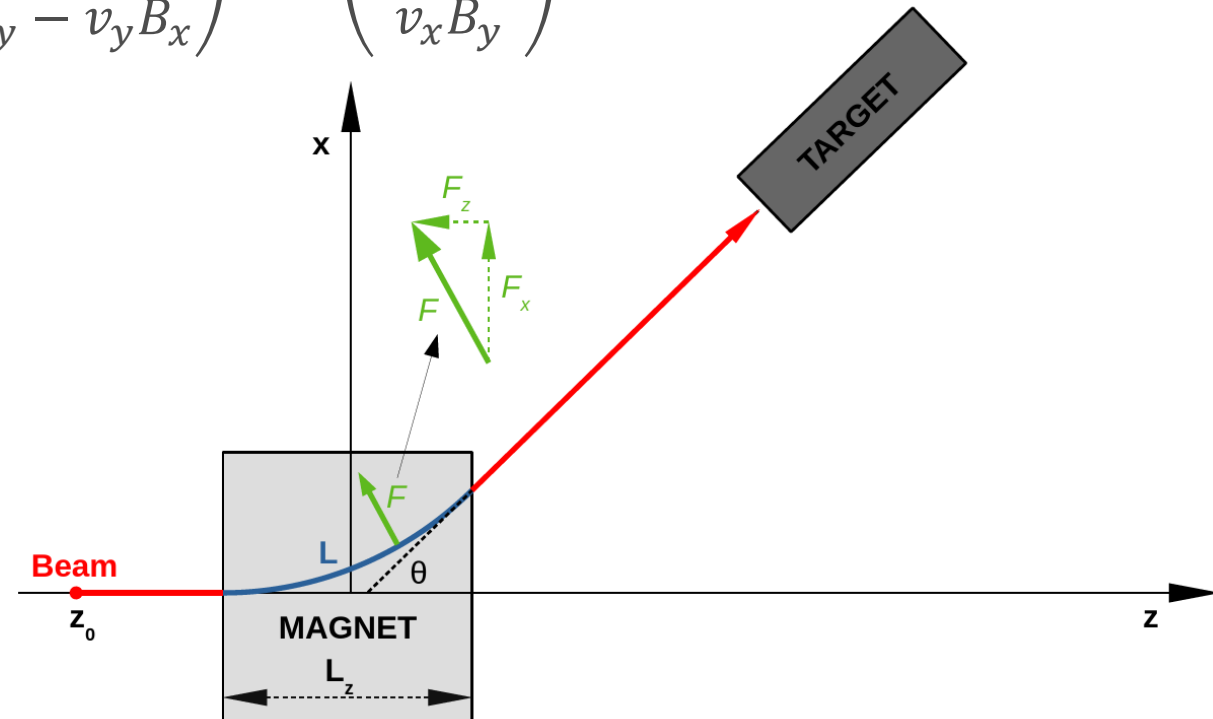

# Required $|B|$

- Required B field strength of a **50 cm** long dipole to deviate a **600 MeV/c** proton beam by **25 deg**:

$$|B| [T] = \frac{0.6 [GeV/c]}{0.299792 * 1 [e] * 0.5 [m]} \sin\left(\frac{25}{180} * \pi\right) = 1.69164 [T]$$

# The cards

- **ASSIGNMA** (under “Media”):

```
ASSIGNMA      Mat: VACUUM ▼   Reg: MAGNET ▼ to Reg: ▼  
              Mat(Decay): ▼   Step:           Field: Magnetic ▼
```

- **MGNFIELD** (under “Transport”):

```
MGNFIELD  Max Ang (deg): Bound Acc. (cm):   Min step (cm):  
          Bx: 0.0           By: -1.69164           Bz: 0.0
```

# Plotting the field

- Since the B-field only has a y component, let's for example chose the x-y plane for plotting:

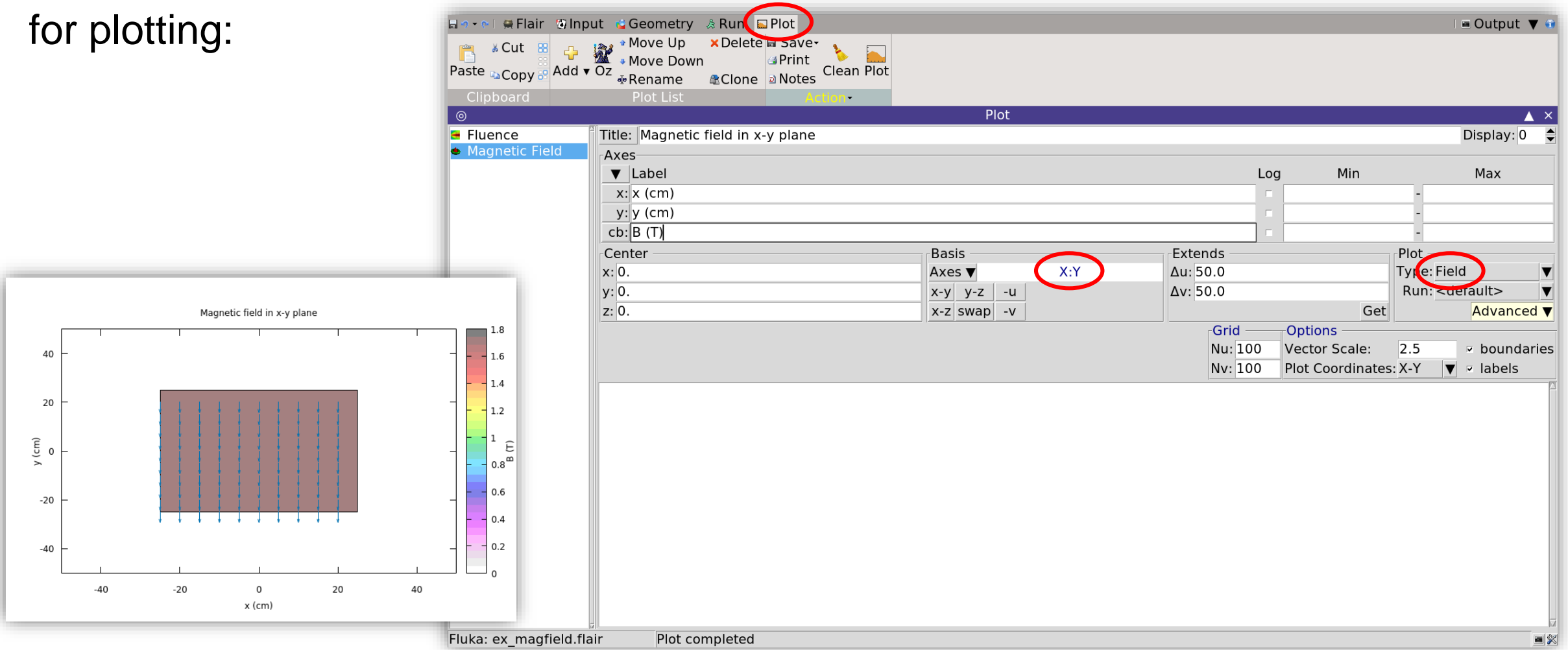

# Particle fluence in x-z plane

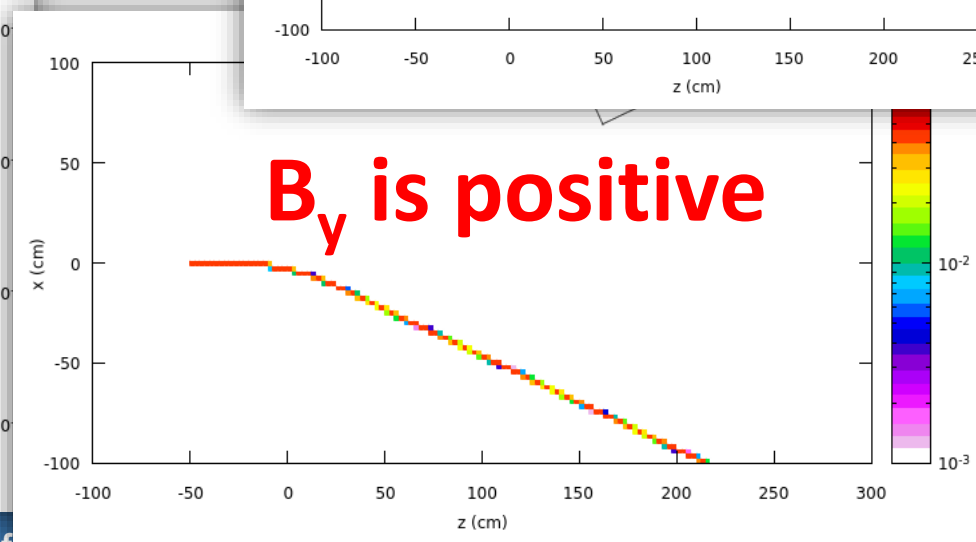
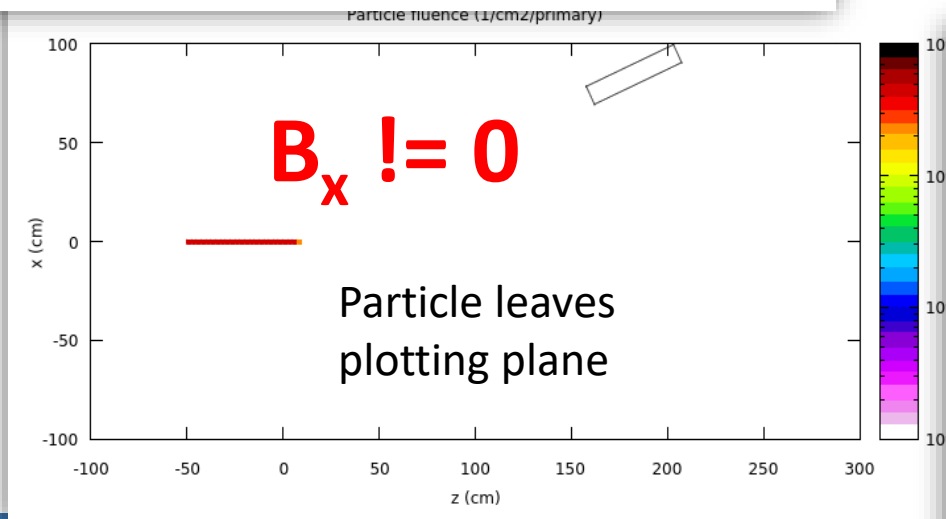
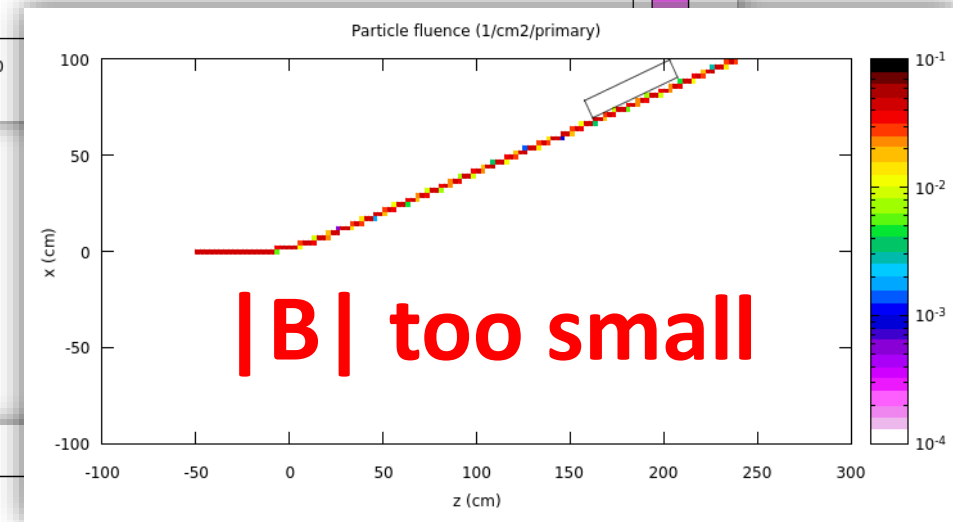
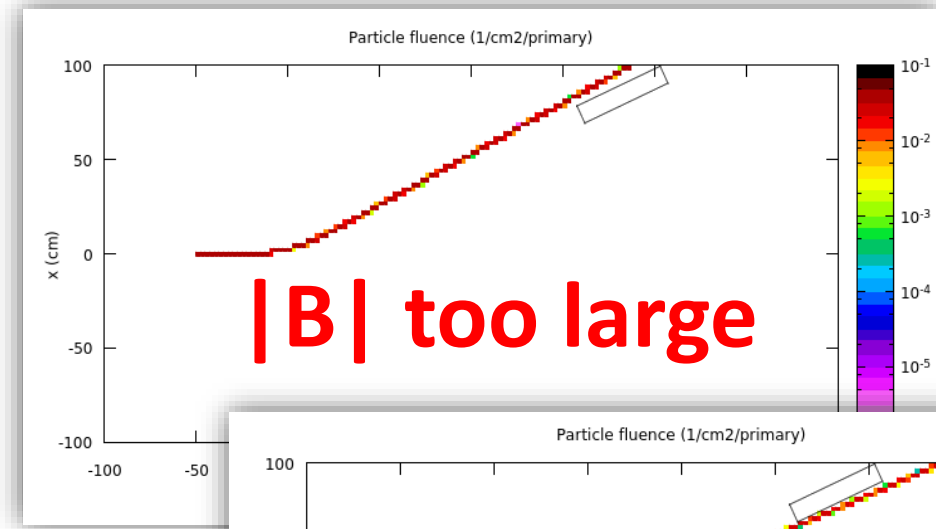
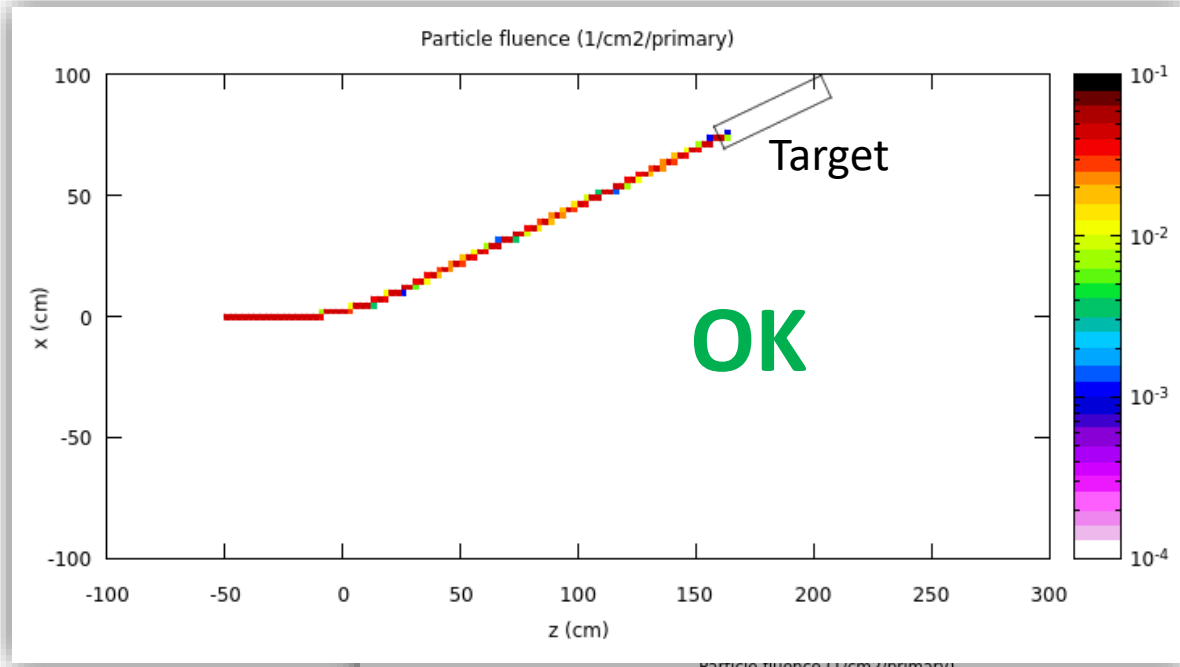

# CURSO INTRODUTÓRIO



23 DE JANEIRO  
A 8 DE MARÇO  
DE 2023

FLUKA

FLUKA

FLUKA

FLUKA

FLUKA

# AULA 14

# Campos eletromagnéticos

Obrigada pela participação

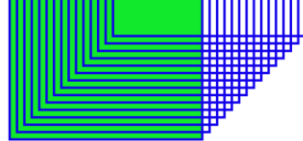

Código Monte Carlo de interação e transporte de partículas



01

02

03

04

05

06

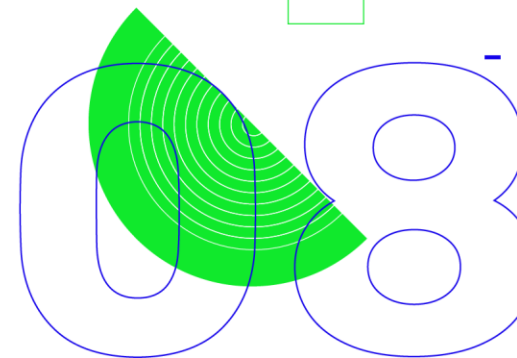
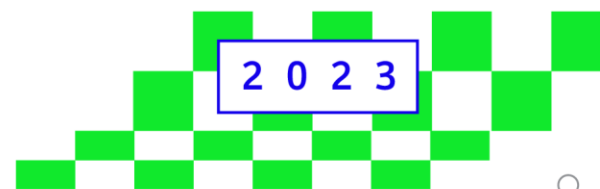

01

02

03

04

05

06