

# Radiation Shielding Design for SSRL Beamlines at SLAC

Md Ahmed, Shanjie Xiao, James C. Liu

SLAC National Accelerator Laboratory, Menlo Park, California

06/26/2025



RadSynch25, Campinas, Brazil

# Outline

---

- Overview of SSRL facility
- Generic beamline shielding design
- Overview of SSRL beamline 10 (BL10)
- Shielding design analysis for BL10
  - Gas Bremsstrahlung (GB)
  - Synchrotron Radiation (SR)

# Outline

---

- Overview of SSRL facility
- Generic beamline shielding design
- Overview of SSRL beamline 10 (BL10)
- Shielding design analysis for BL10
  - Gas Bremsstrahlung (GB)
  - Synchrotron Radiation (SR)

# Stanford Synchrotron Radiation Lightsource (SSRL) Facility at SLAC

---



# Stanford Synchrotron Radiation Lightsource (SSRL) Facility at SLAC

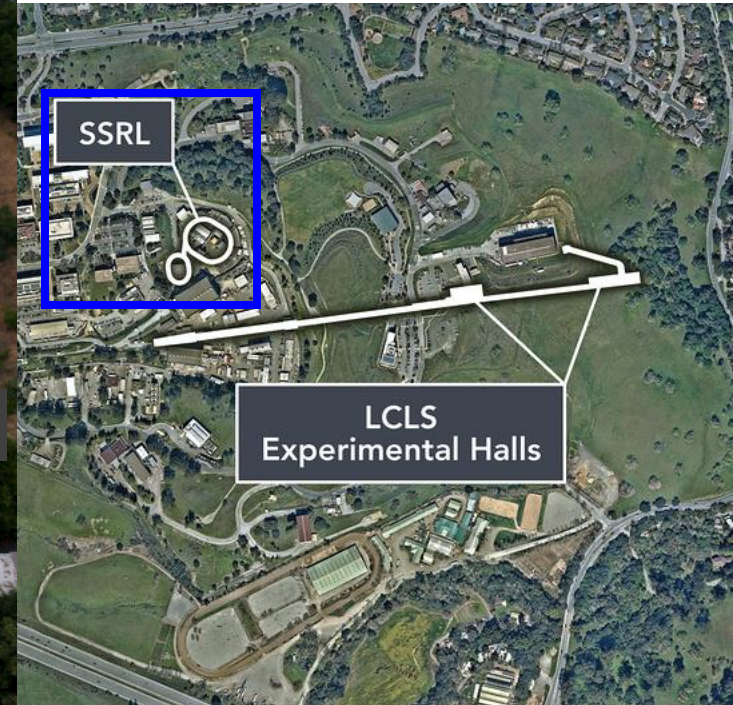
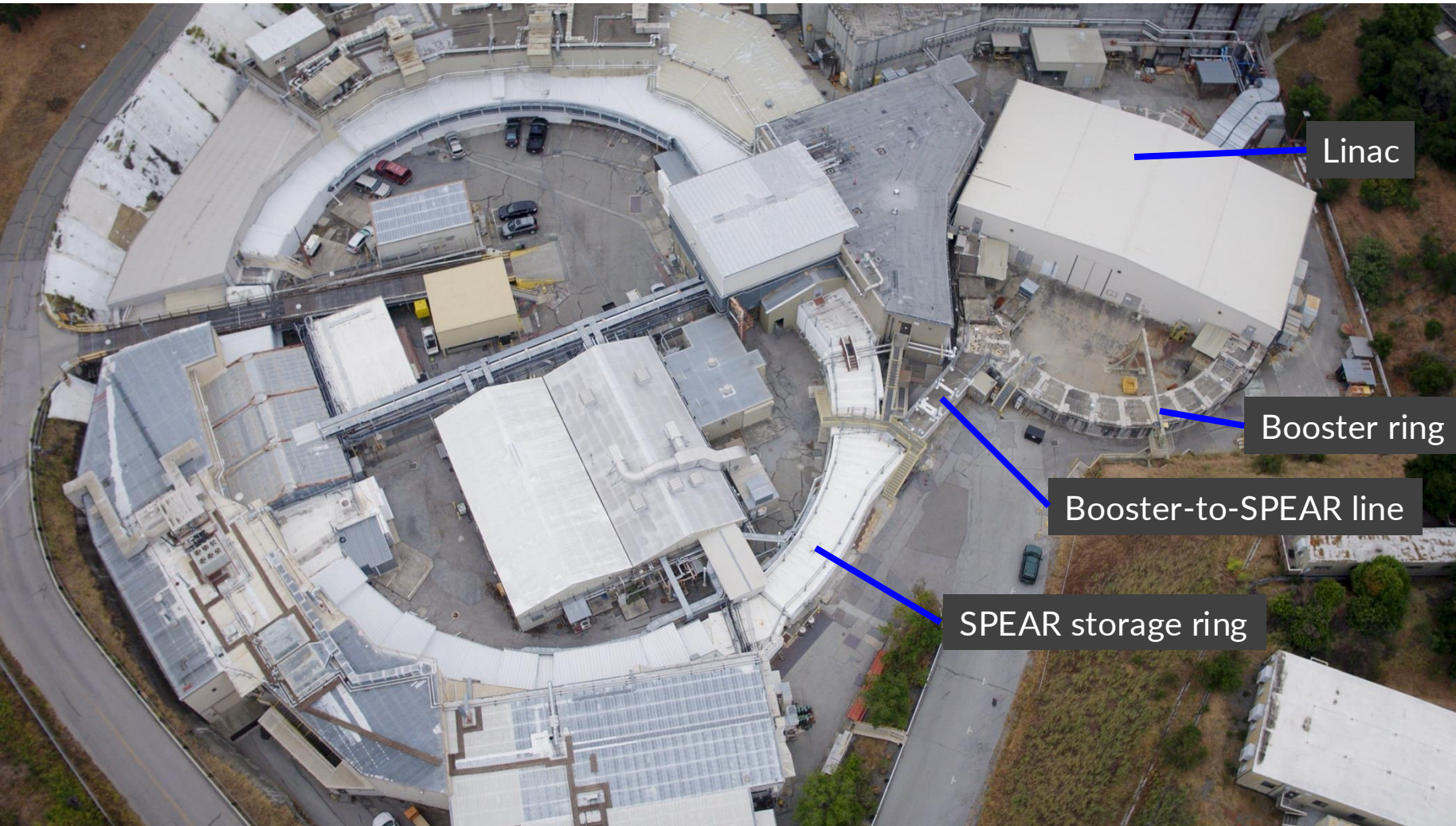

SPEAR stands for generation Stanford Positron Electron Asymmetric Ring

# Overview of SSRL facility

SSRL facility includes the following:

- Injector (10 Hz)
  - Electron gun
  - Gun-to-Linac transport (GTL) line
  - Linear accelerator and Diagnostic room
  - Linac-to-Booster transport line (LTB)
  - Booster synchrotron
  - Booster-to-SPEAR (BTS) line
- 3 GeV SPEAR3 electron storage ring (234 m)
  - 16 synchrotron beamlines

	Typical Operation
Gun	3.2 MeV, 16 W
LTB	120 MeV, 0.4 W
BTS	3.0 GeV, 3.0 W
SPEAR3	3.0 GeV, 500 mA

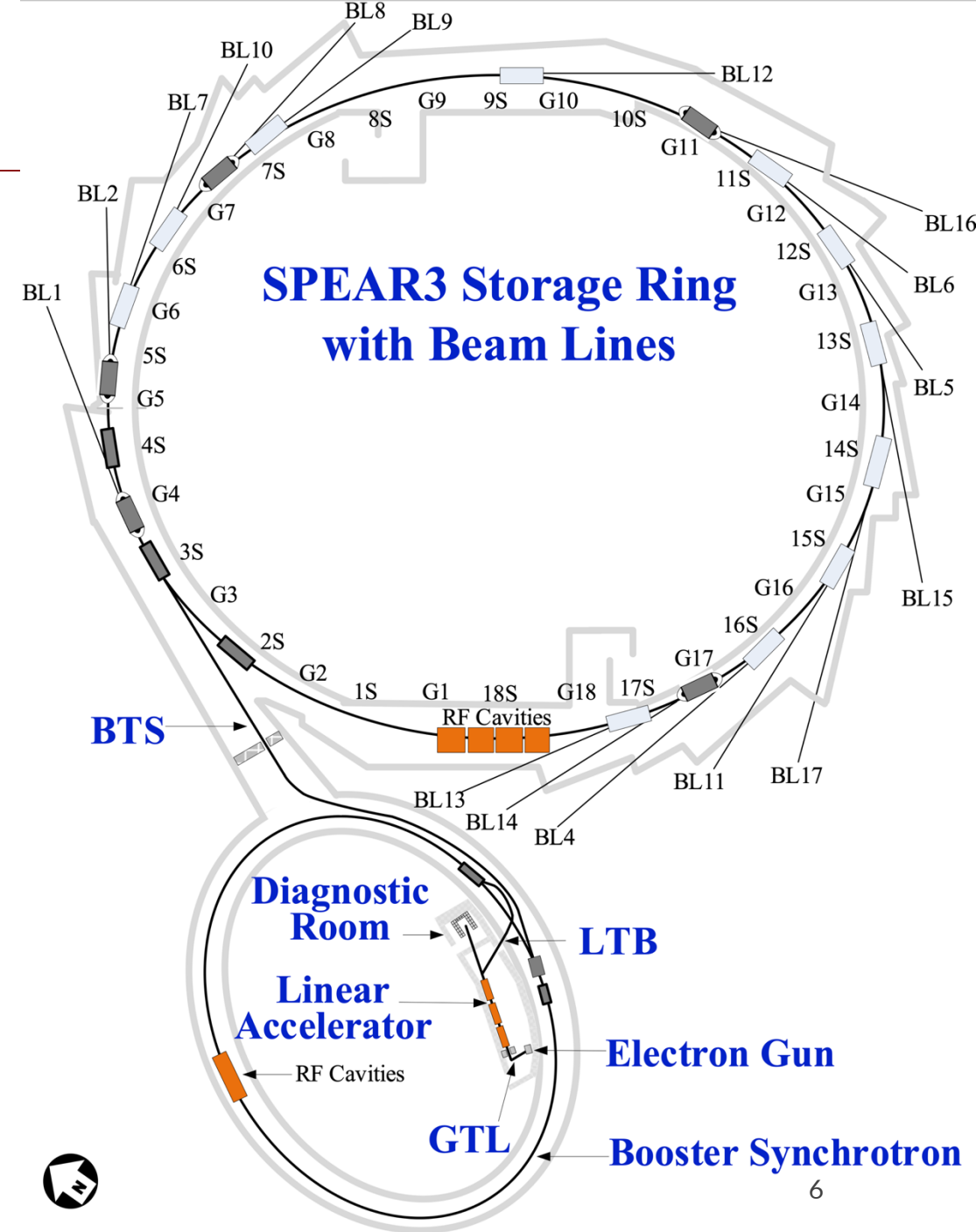

# Overview of SSRL facility

SPEAR3 storage current is replenished or topped-off by injecting  $\sim 6$  mA/5 min (lifetime of  $\sim 6.5$  h)

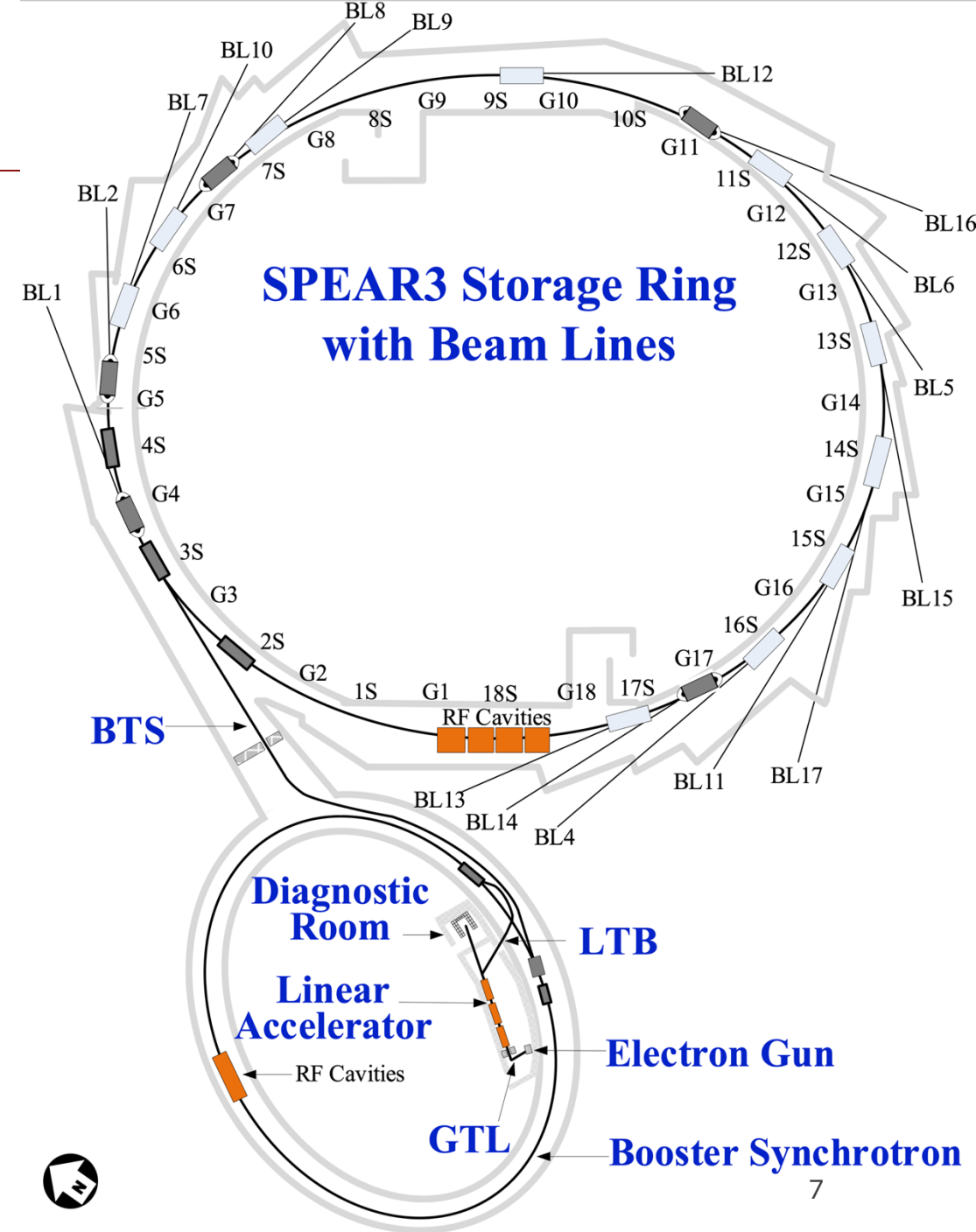
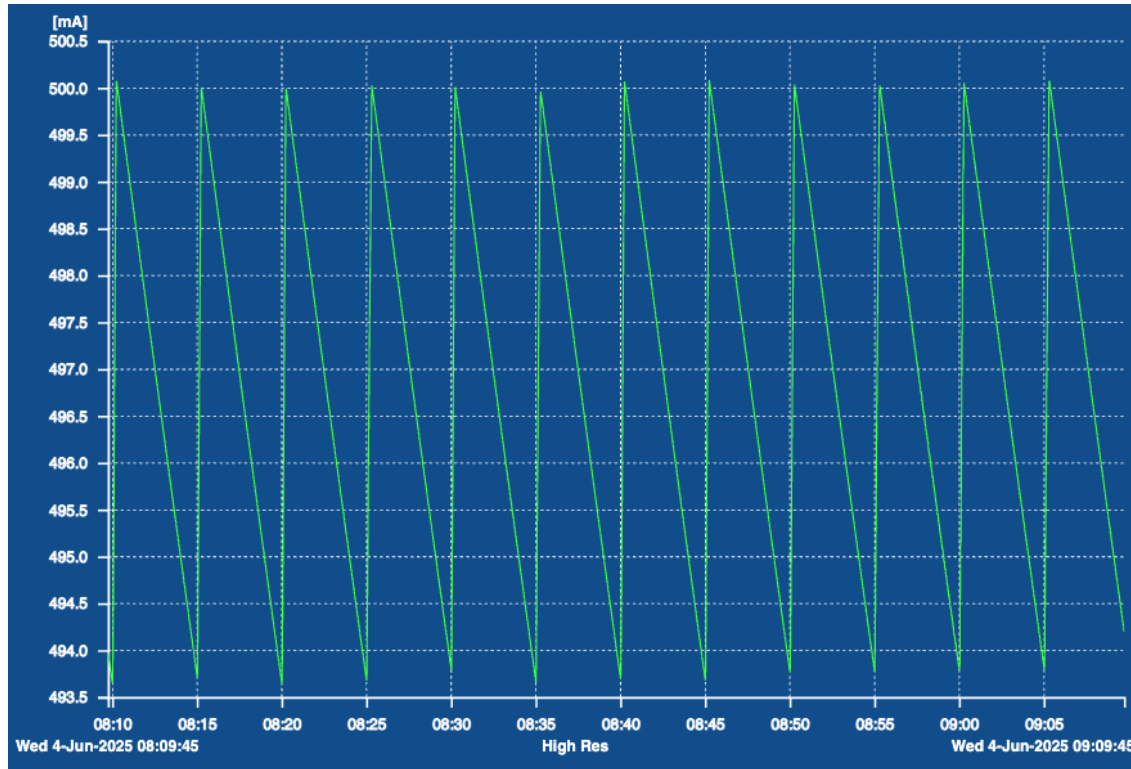

# Outline

---

- Overview of SSRL facility
- **Generic beamline shielding design**
- Overview of SSRL beamline 10 (BL10)
- Shielding design analysis for BL10
  - Gas Bremsstrahlung (GB)
  - Synchrotron Radiation (SR)

# Shielding Design Limits

---

Users do not require to wear a personal dosimeter in the SSRL experimental floor

Operating Condition	Effective Dose Rate	Integrated Effective Dose
Normal	1.0* $\mu\text{Sv/h}$ for 1000 h/y	1 mSv/year
Mis-steering	4 mSv/h	N/A
System failure	250 mSv/h	30 mSv/event

\*Within area where personnel entrance is restricted, the limit can be higher

- For example, the dose rate limit for the hutch roof can be 5  $\mu\text{Sv/h}$  considering an occupancy factor of 0.1

# Radiation Types Considered

---

- **Gas Bremsstrahlung (GB)**
  - **Primary or 0-degree GB**
    - Created via interaction with the residual gas in the 6-m straight section
  - **Scattered GB**
    - Scattered by optical components, which include apertures/mirrors/monochromator
- **Synchrotron Radiation (SR)**
  - **White light**
    - Direct SR created by bend magnet or insertion device
  - **Filtered light**
    - Photons reflected/scattered from a mirror/mono
  - **Mono light**
    - Mono-energetic photons from a monochromator

# Generic Beamline Shielding Design Curves: GB

Longitudinal shielding was determined analytically

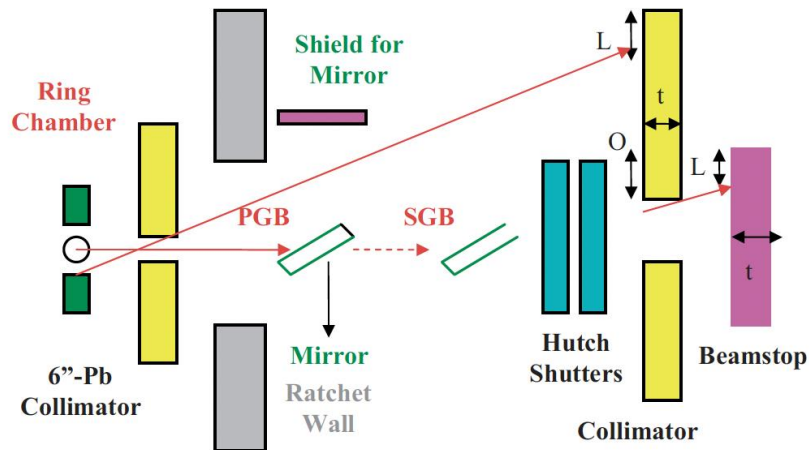

Table 4. Longitudinal thickness, lateral extension, and overlap requirements for beamline safety components (collimators, hutch stoppers, and beamstop) in an ID beamline under the 100-mA and 500-mA operation for primary GB and secondary GB<sup>1</sup>.

Stored Current	100 mA		500 mA	
GB Type <sup>2</sup>	Primary	Secondary	Primary	Secondary
Longitudinal Thickness <sup>3</sup>	9'' Pb	8'' Pb	10'' Pb	9'' Pb
Lateral Extension <sup>4</sup>	1'' Pb	0.5'' Pb	2'' Pb	1'' Pb
Overlap <sup>5</sup>	1/8'' Pb	1/8'' Pb	1/8'' Pb	1/8'' Pb

FLUKA-code was used to generate shielding curves for scattered beam

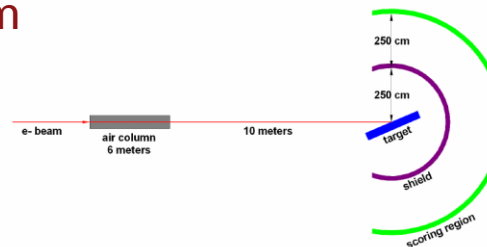
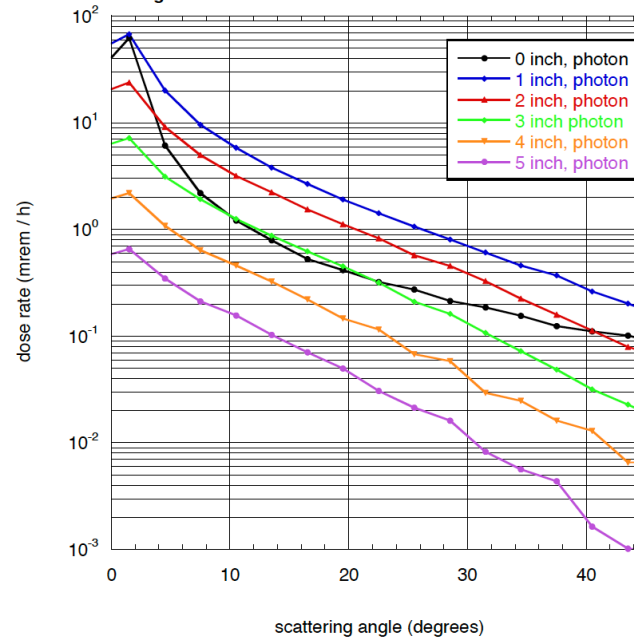
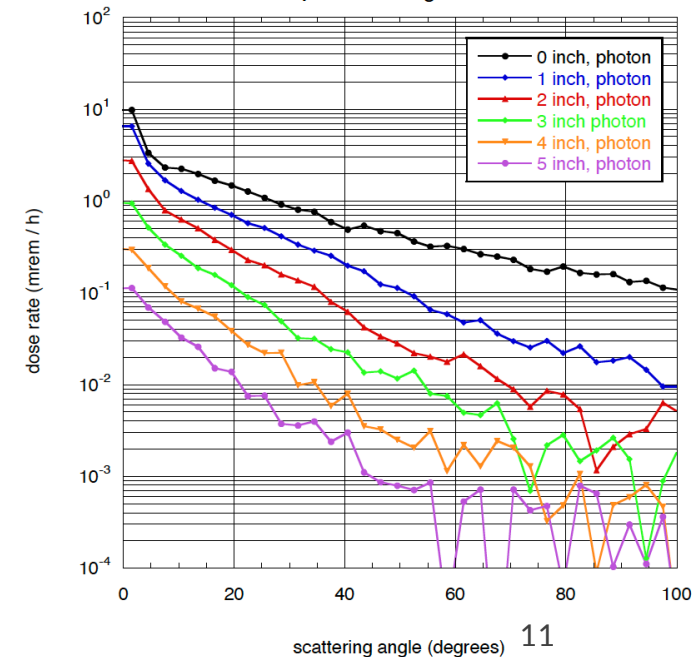

Figure 1. Simplified diagram of the FLUKA geometry (not to scale). Cross section as seen from above.

GB dose rate from photons at 1 m vs scattering angle for optics hutch with Pb shield of various thicknesses. (Shield geometry = vertical cylinder.) Si target (8 cm thick, 3 cm wide and 1 m long) slanted at 0.2 degrees. GB from 500 mA, 3 GeV e- pencil beam through 6 m of air at 1 nTorr. End of air column is 10 m upstream of target.



GB dose rate from photons at 1 m vs scattering angle for optics hutch with Pb shield of various thicknesses. (Shield geometry = vertical cylinder.) Long Cu target (6 X 1 X 1 inch). GB from 500 mA, 3 GeV e- pencil beam through 6 m of air at 1 nTorr. End of air column is 10 m upstream of target.



# Generic Beamline Shielding Design Curves: SR

STAC8 code was used to generate the generic shielding curves

Example of shielding curve for **white light** (perpendicular Cu target)

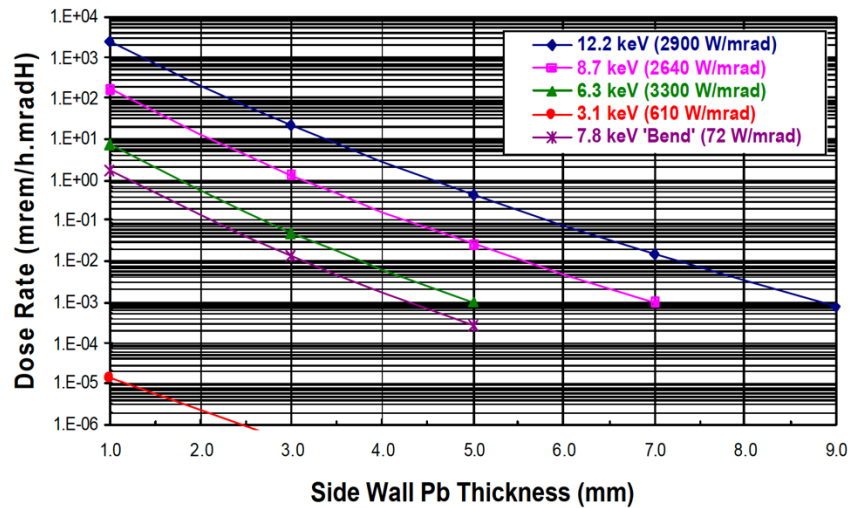

Example of shielding curve for **filtered light** (inclined Si-target)

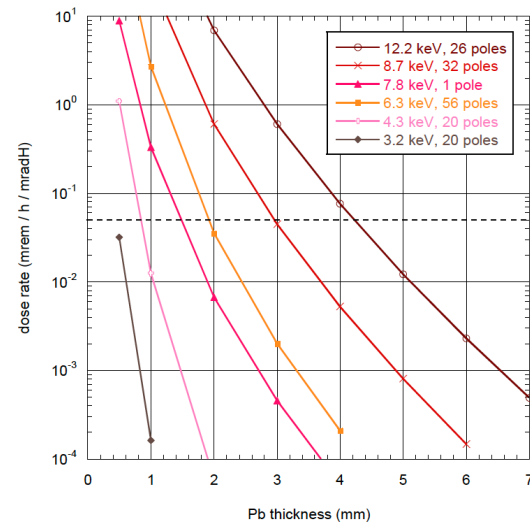

Example of shielding curve for **mono light** (inclined Si-target)

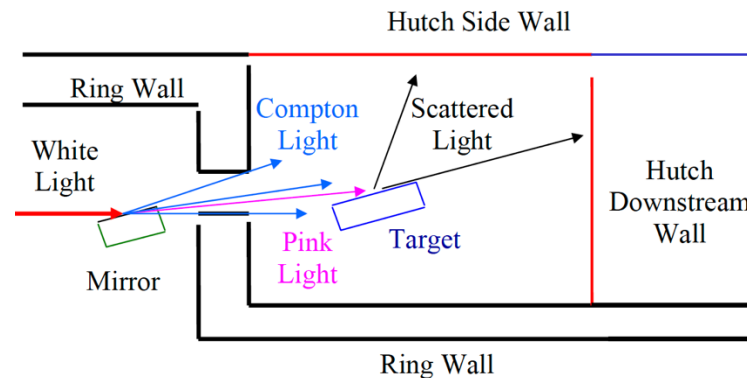
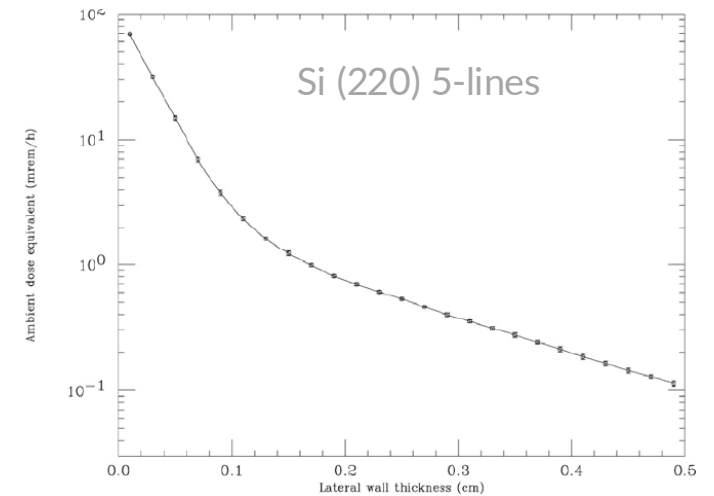

# Outline

---

- Overview of SSRL facility
- Generic beamline shielding design
- **Overview of SSRL beamline 10 (BL10)**
- Shielding design analysis for BL10
  - Gas Bremsstrahlung (GB)
  - Synchrotron Radiation (SR)



# BL10 Major Optical Components

Top-View of BL10 Frontend

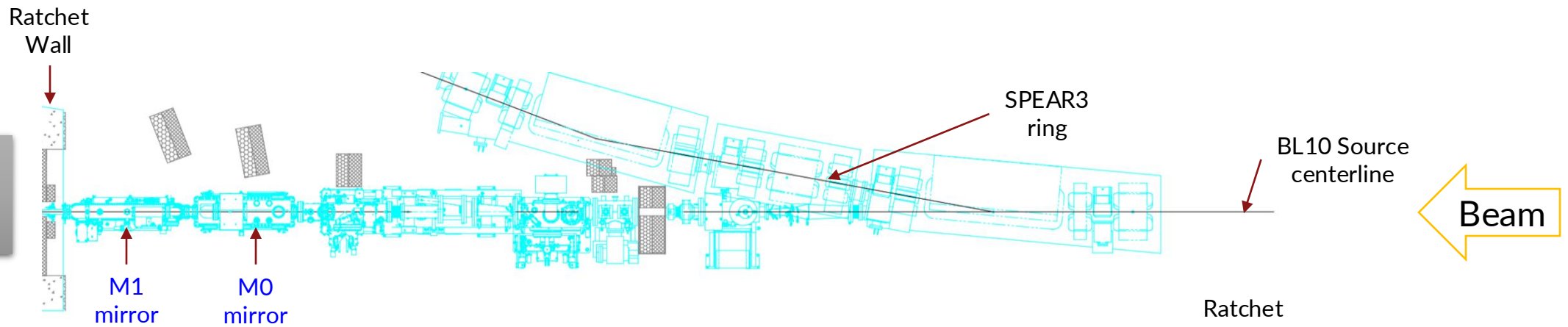

Top-View of BL10 Hutches

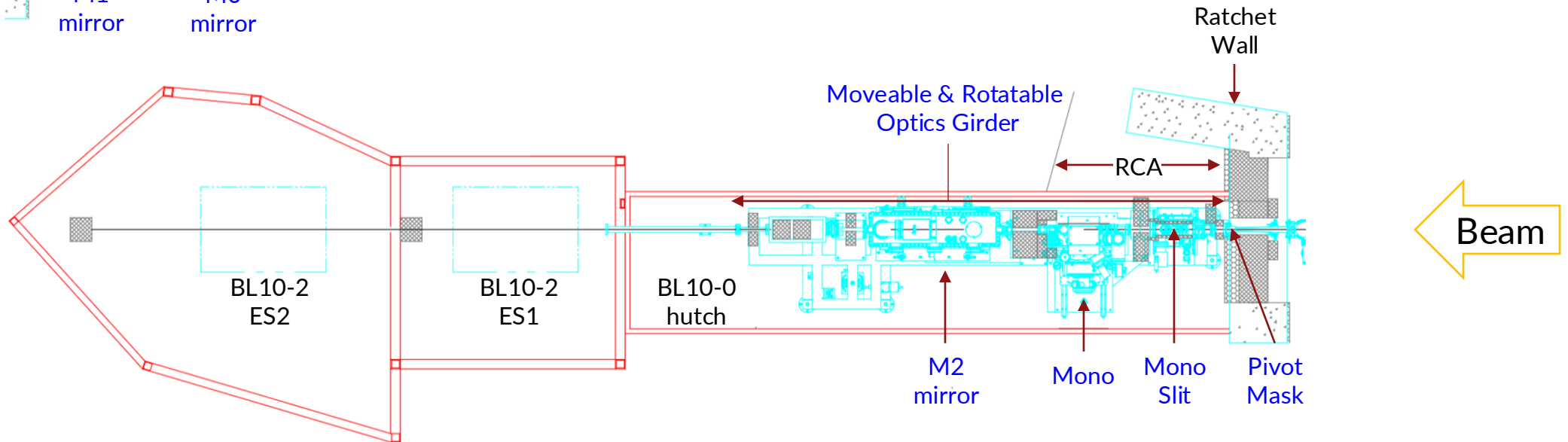

M0	Low pass cutoff for SR: 13.0 keV	collimates beam	reflects upward
M1	Low pass cutoff for SR: 21.3 keV	focuses beam	reflects upward
M2	Low pass cutoff for SR: 13.0 keV	collimates beam	deflects downward

# BL10 Safety Components: Frontend

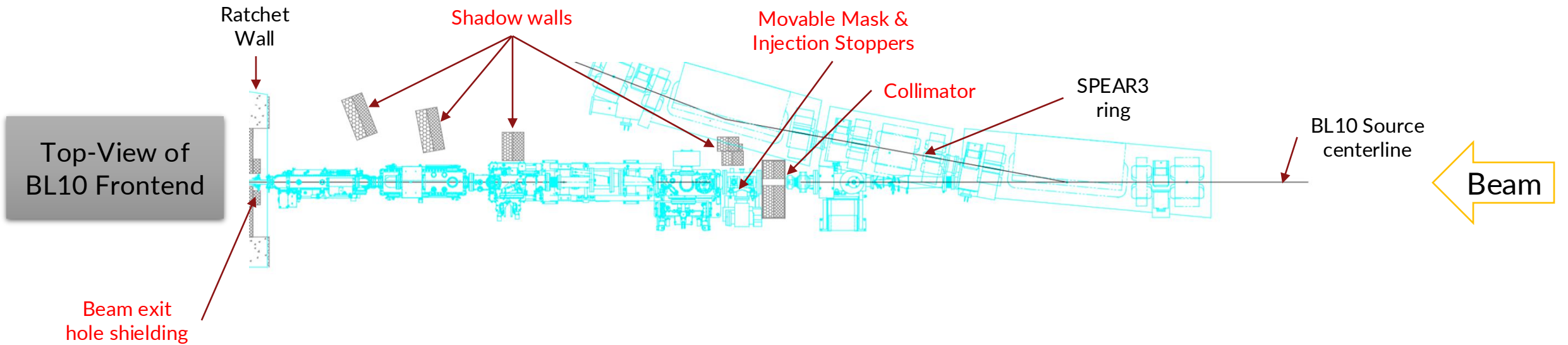

- PPS-interlocked **Movable Mask** and **Injection Stoppers** isolate beamline from the ring radiation hazard
- **Collimator**, **shadow walls**, and **beam exit hole shielding** block scattered radiation from beam losses in the ring from escaping through beampipe hole

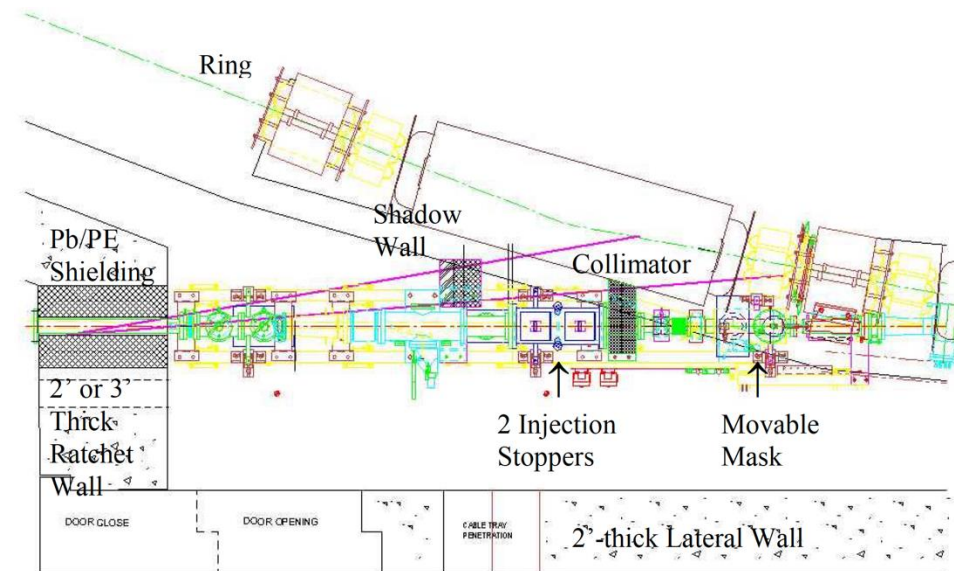

# BL10 Safety Components: Hutches

- GB scattering targets:
  - Pivot mask
  - Monochromator slits
  - Monochromator Burn Through Monitor (BTM)
- SR scattering targets:
  - Pivot mask
  - Monochromator slits
  - Monochromator

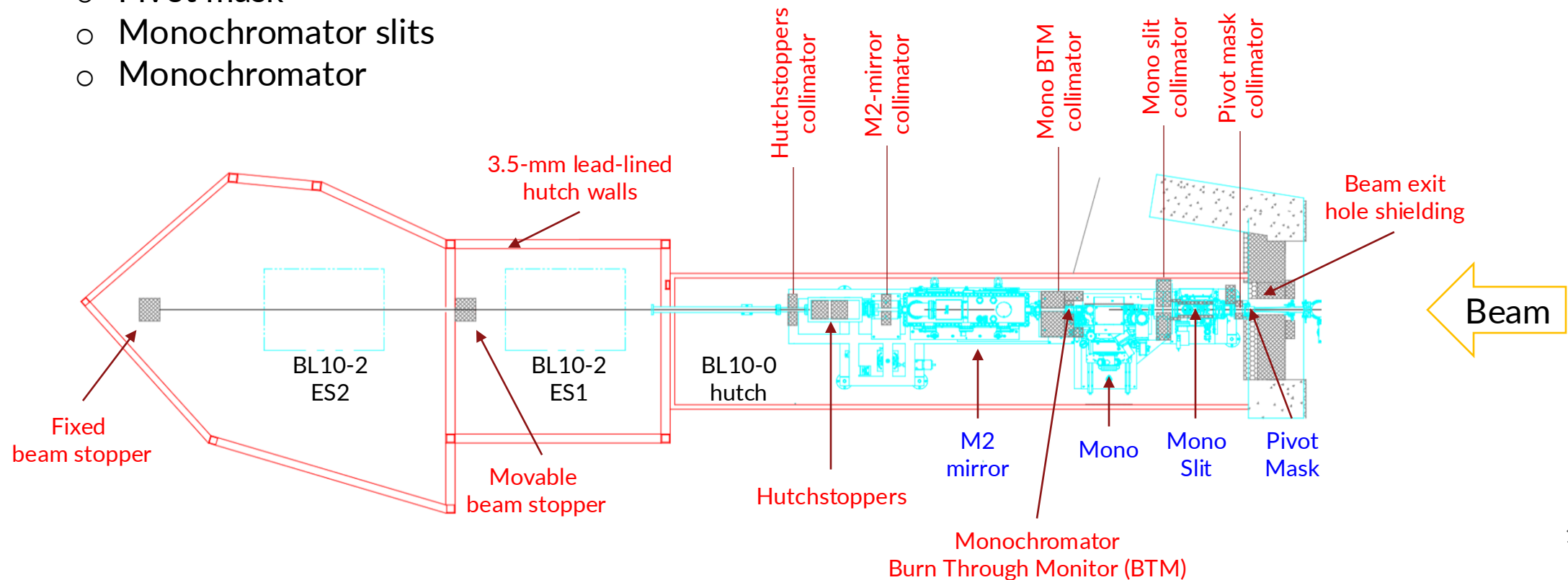

# BL10 Safety Components: Hutches

- The BL10 monochromator includes a pressurized Burn Through Monitor (BTM) at its exit to intercept beam undeflected by the mono – dumps beam if pressure is lost
- Includes a 35-mm thick Molybdenum block upstream of the BTM tube

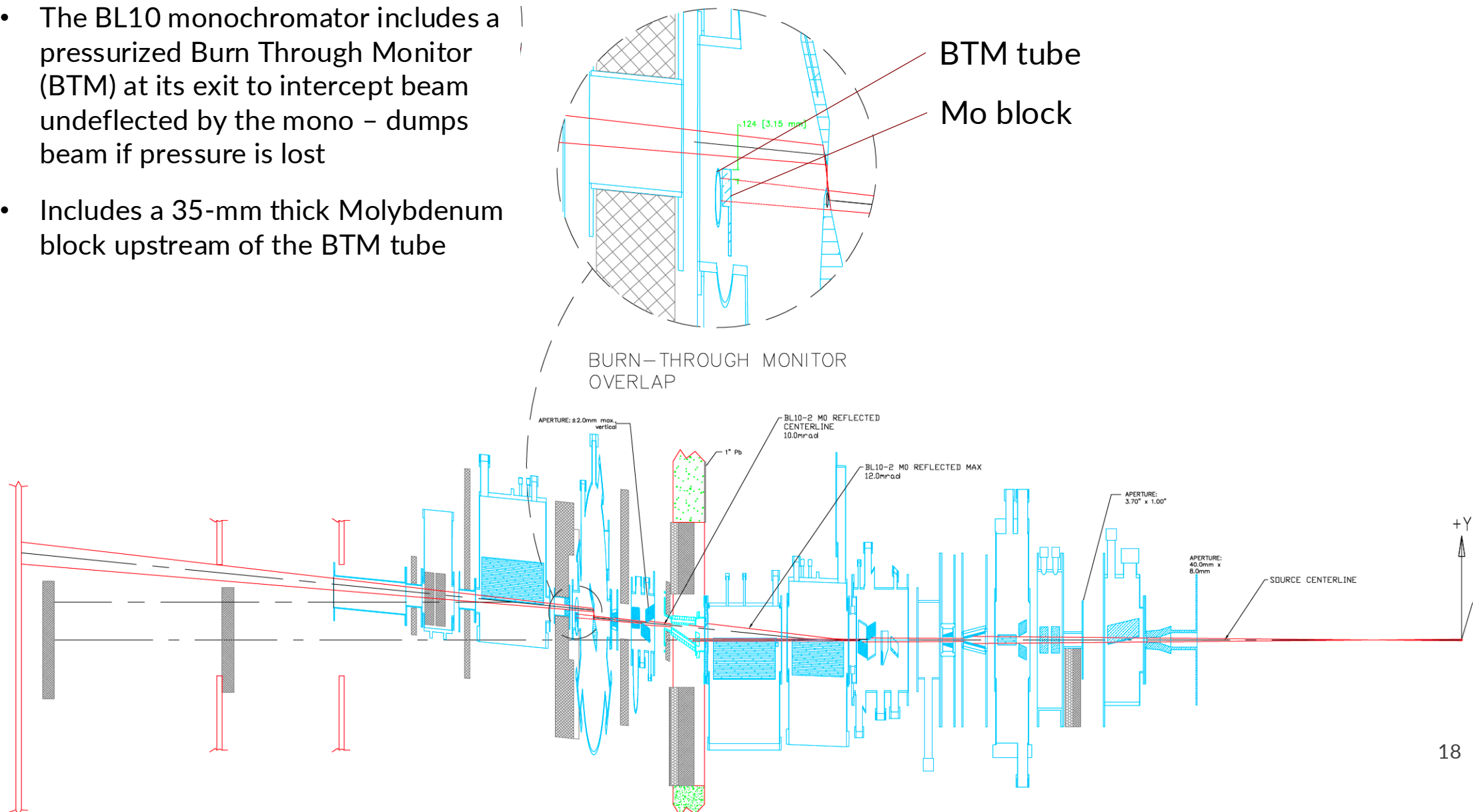

# Outline

---

- Overview of SSRL facility
- Generic beamline shielding design
- Overview of SSRL beamline 10 (BL10)
- **Shielding design analysis for BL10**
  - **Gas Bremsstrahlung (GB)**
  - Synchrotron Radiation (SR)

# GB Shielding Design Analysis

- **Source Term**

GB generated by 3 GeV, 500 mA electron beam while passing through 6-m long gas section at  $10^{-9}$  Torr pressure: **38  $\mu$ W**

- **Analysis Method**

FLUKA simulation

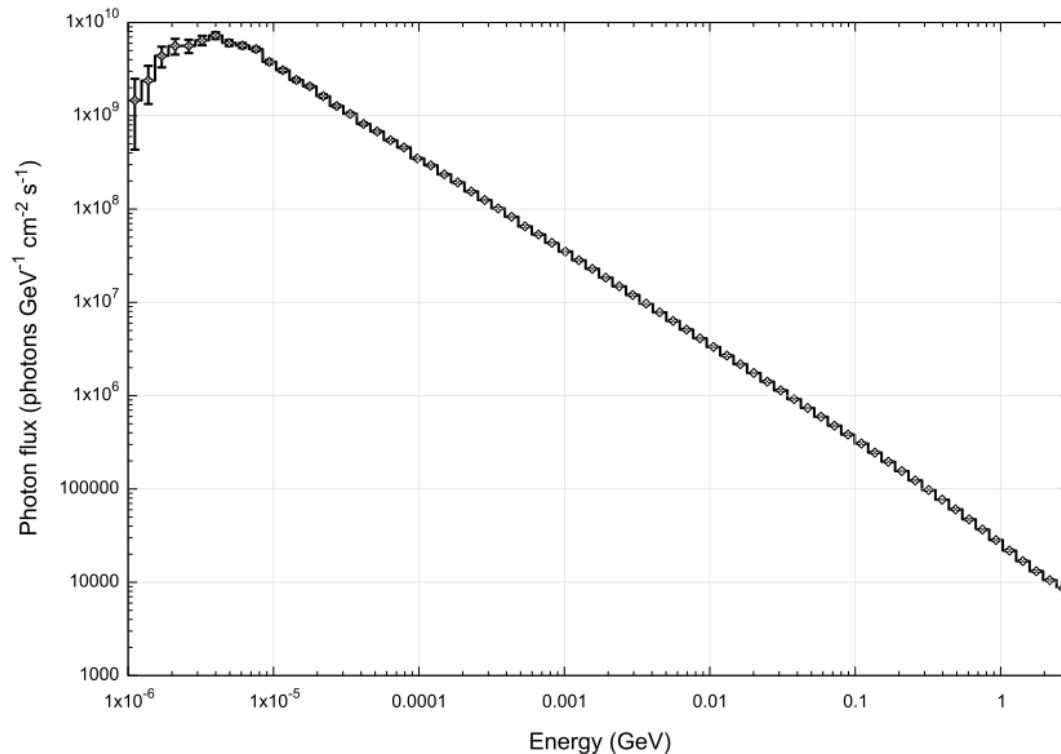

GB spectrum calculated in FLUKA simulation

- **Operation modes analyzed**

- **Normal operation**

- White light
- Filtered light

- **Normal but transient conditions**

- White light with mono slit closed
- Filtered light with optics girder misaligned

- **5-W Mis-steered beam**

# Additional GB Shielding for Mono BTM: white light mode

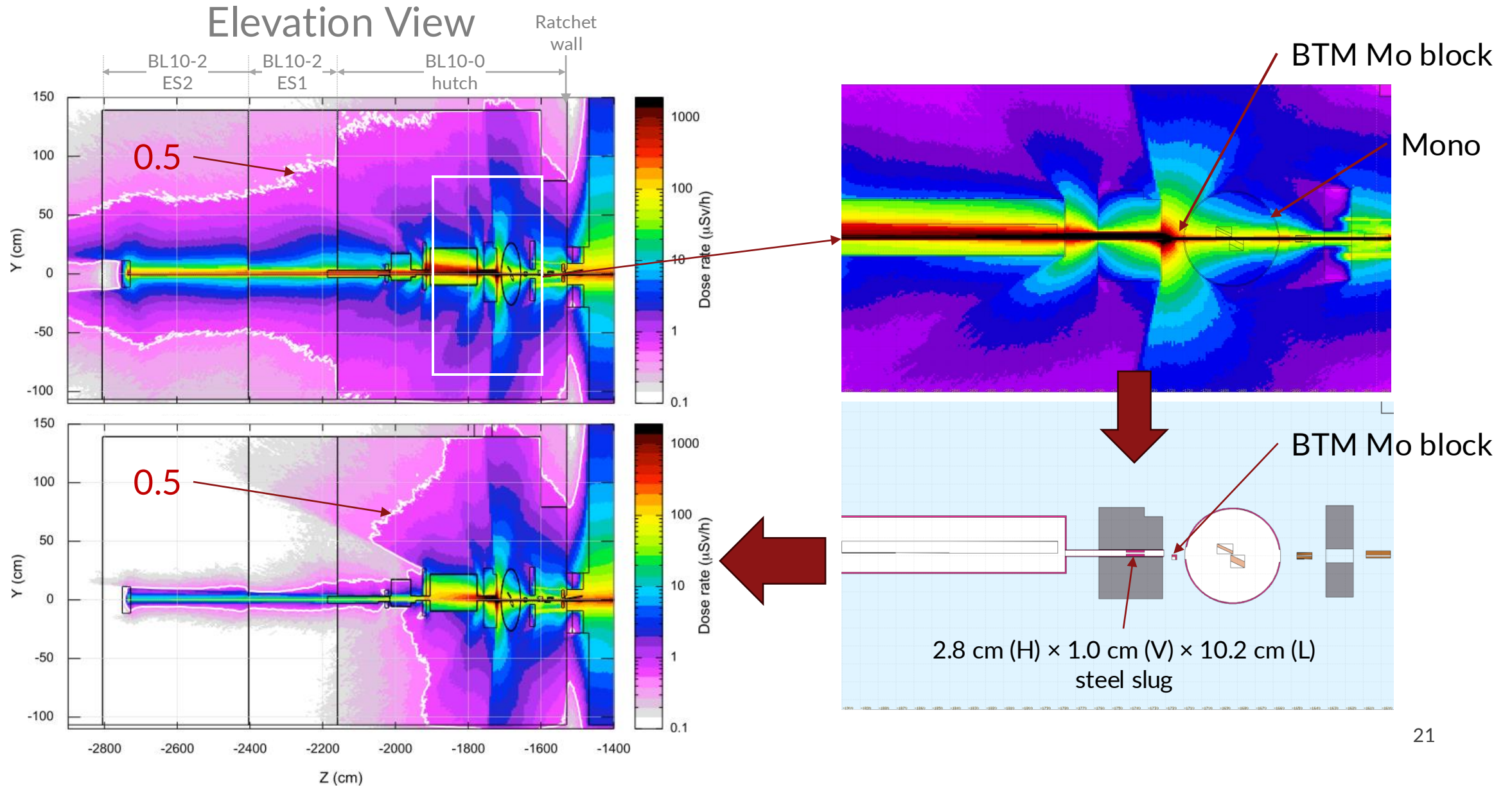

# GB Analysis: white light mode, normal operation

Elevation View

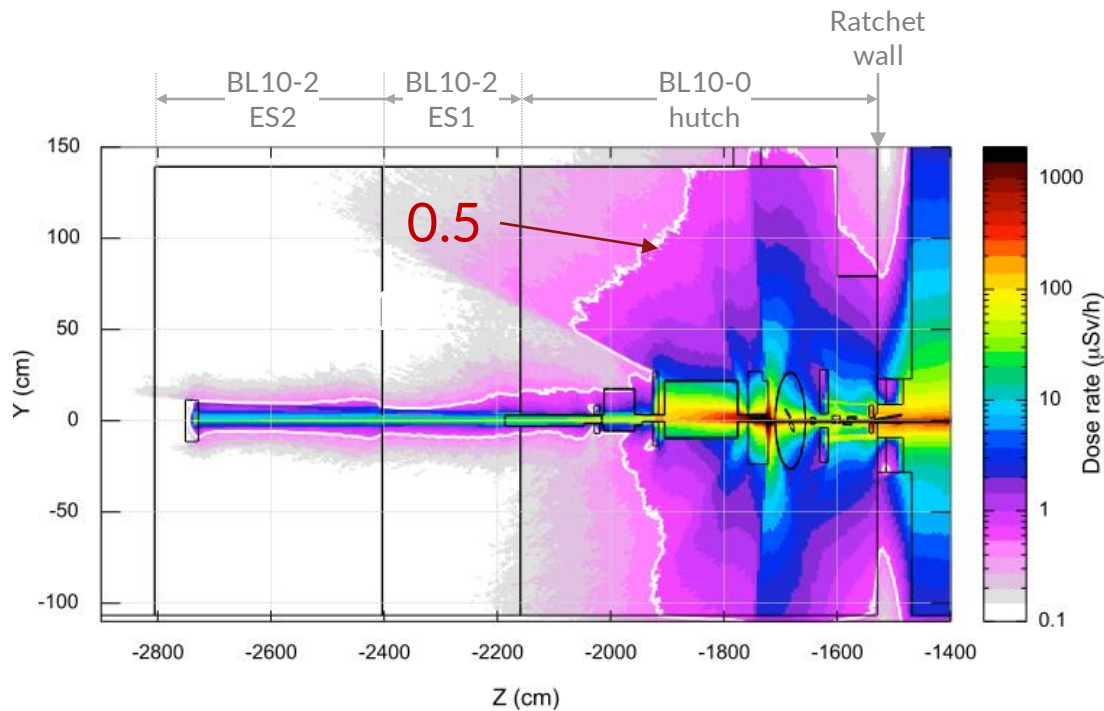

Plan View

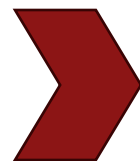
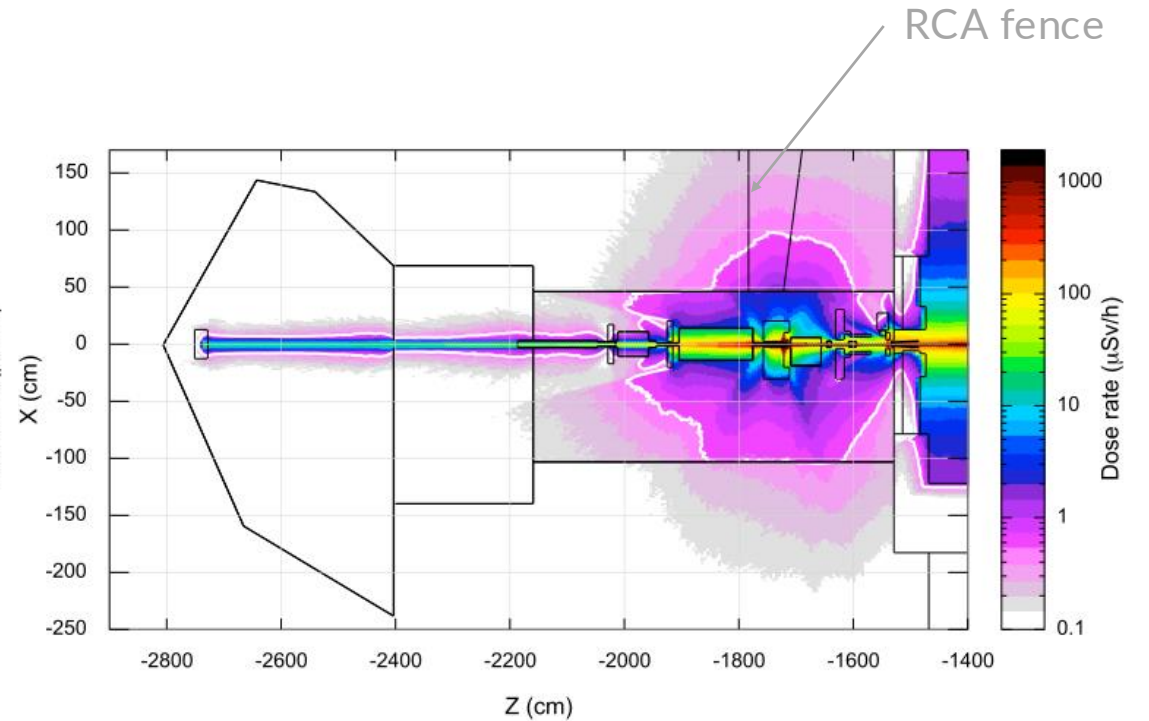

**Location on the experimental floor**

**Max GB Dose Rate @30 cm**

within RCA

0.9  $\mu\text{Sv/h}$

outside RCA

0.6  $\mu\text{Sv/h}$

With SR added, may exceed 1  $\mu\text{Sv/h}$ . Hence this area was posted as Radiologically Controlled Area (RCA), where the limit is 5  $\mu\text{Sv/h}$

# GB Analysis: filtered light mode, normal operation

Elevation View

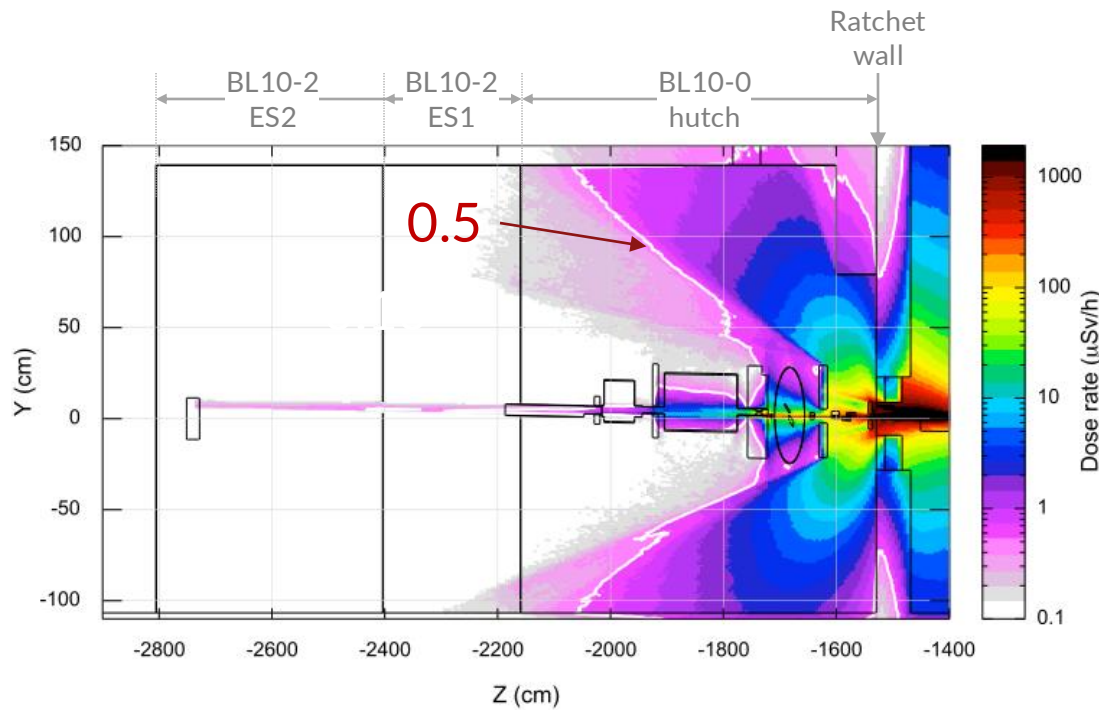

Plan View

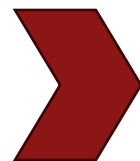
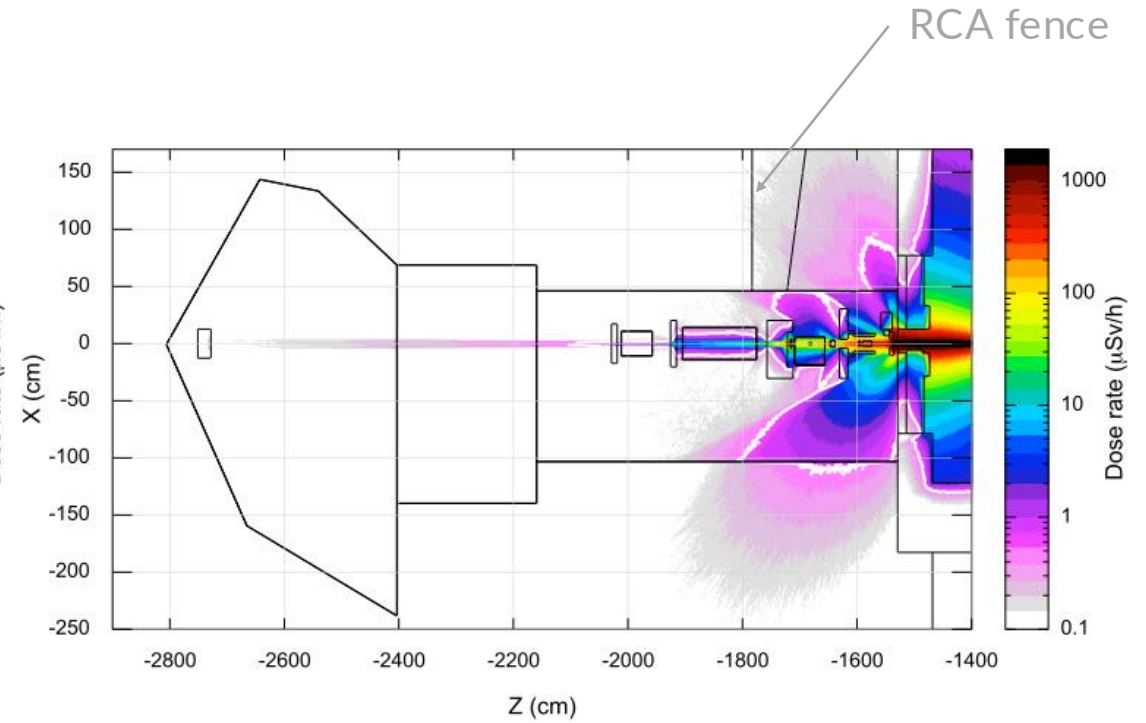

**Location on the  
experimental floor**

**Max GB Dose Rate  
@30 cm**

within RCA

1.0  $\mu\text{Sv/h}$

outside RCA

0.6  $\mu\text{Sv/h}$

# GB Analysis: white light mode, transient – girder misaligned

Elevation View

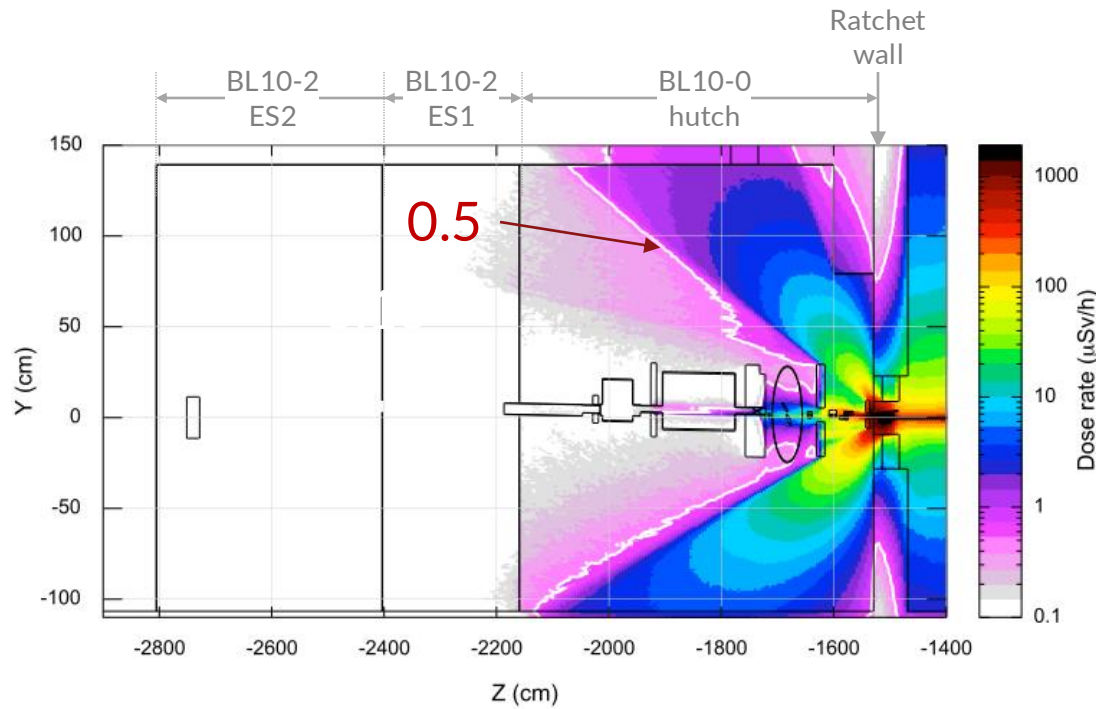

Plan View

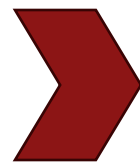
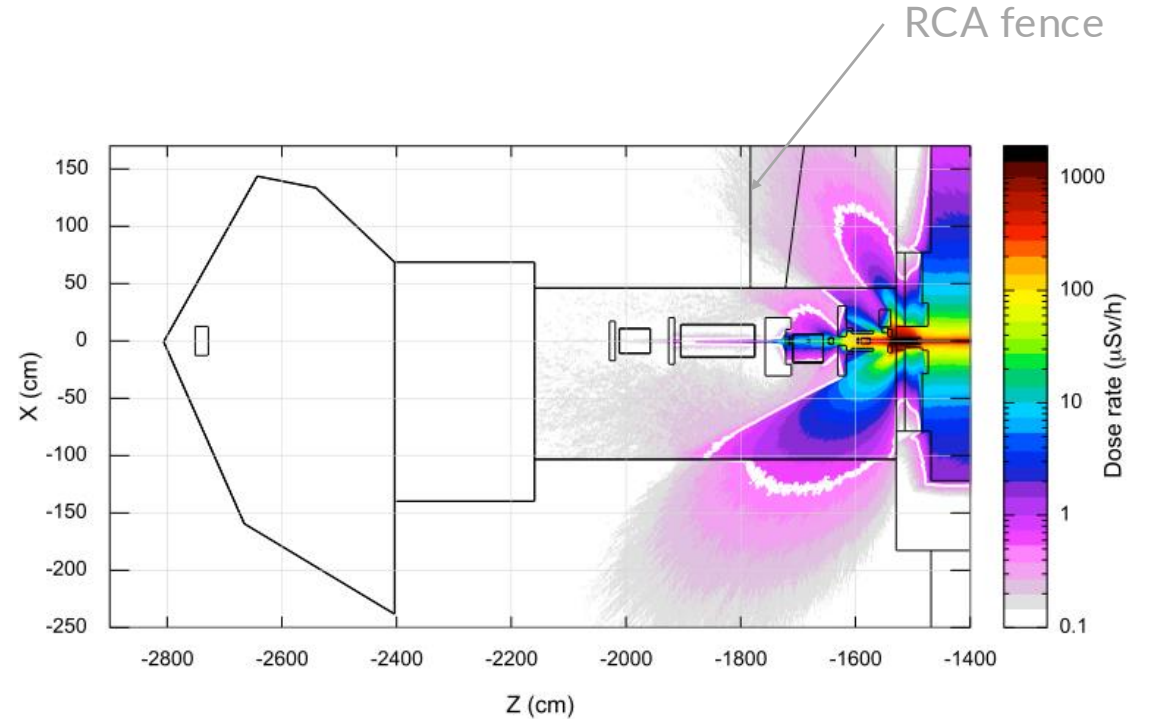

**Location on the experimental floor**

**Max GB Dose Rate @30 cm**

within RCA

2.5  $\mu\text{Sv/h}$

outside RCA

1.3  $\mu\text{Sv/h}$

Exceeds limit, but this is not a running condition

# Outline

---

- Overview of SSRL facility
- Generic beamline shielding design
- Overview of SSRL beamline 10 (BL10)
- Shielding design analysis for BL10
  - Gas Bremsstrahlung (GB)
  - **Synchrotron Radiation (SR)**

# SR Shielding Design Analysis

- **Source Term**

SR light with maximum unfiltered power of 2.1 kW with critical energy of 8.7 keV

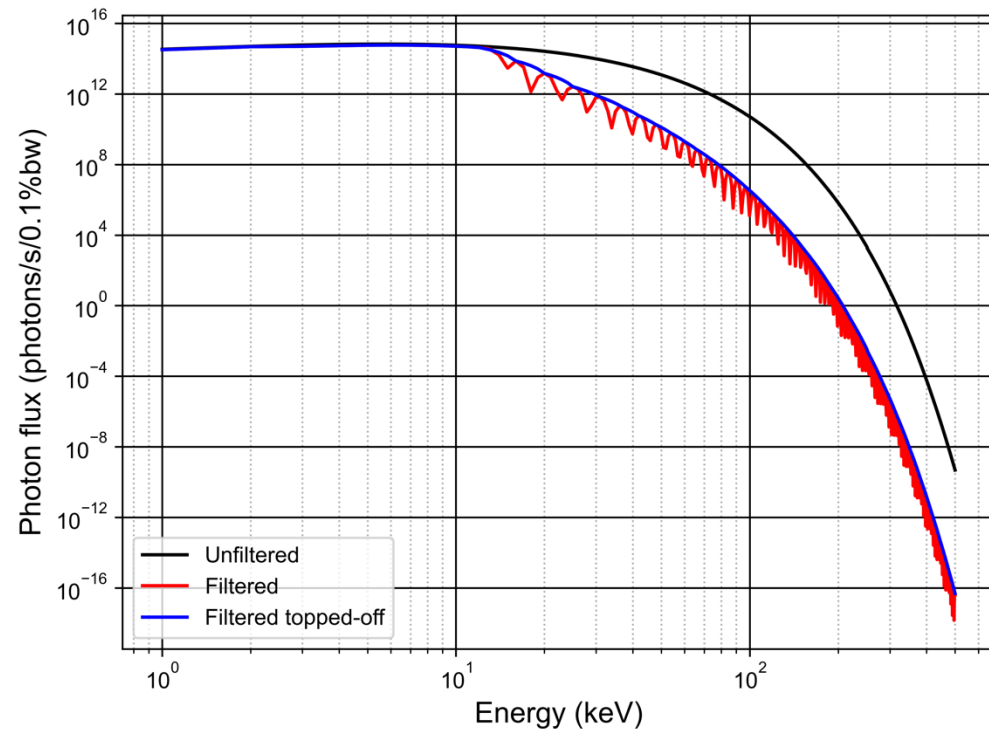

- Unfiltered spectrum was generated using SPECTRA code
- Filtered spectrum was calculated by applying mirror reflectivity analytically
- Filtered topped-off spectrum is the post-processed conservative flux independent of coating thickness variation

- **Operation modes analyzed**

- White light for optics hutch (BL10-0)
- Unfiltered/Filtered mono light for BL10-2 ES1&2
- Direct filtered mono light for BL10-2 ES2

- **Scattering targets considered**

- Pivot mask
- Monochromator slits
- Monochromator

# SR Analysis: White light in Optics hutch (mono shielding)

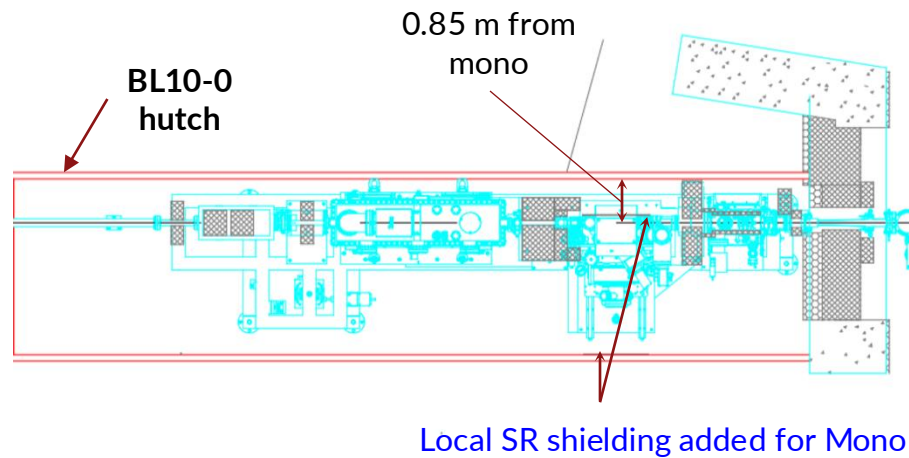

BL acceptance	1 mradH
Unfiltered power density	2124 W/mradH
Nearest distance to hutch wall	0.85 m
Scaling factor	$(2124/2640)/0.85^2 = 1.1$
Dose rate to look up to achieve 0.05 mrem/h.mradH	0.045 mrem/h.mradH
Require lead shielding	4.7 mm
Existing lead shielding in hutch wall	3.5 mm
Dose rate with added 3.2 mm local shielding	0.002 mrem/h

Generic shielding curve\* for white light hutch side walls (at 1-m)

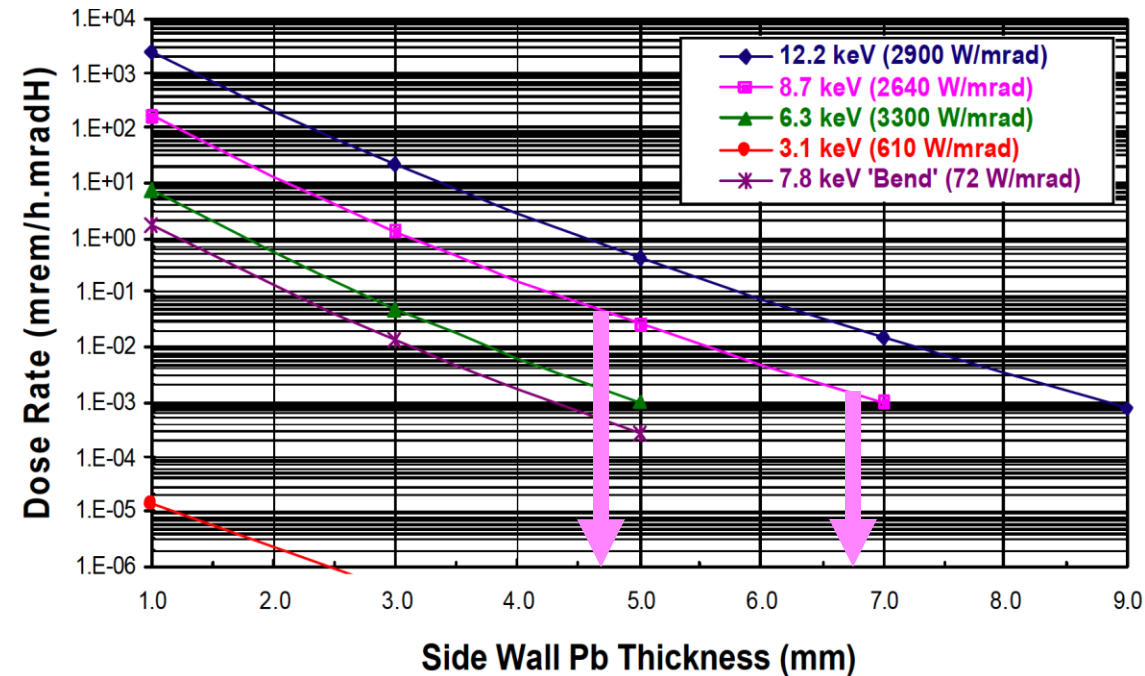

\*James C. L. et al., Rad Meas, 41 (2007) S156-S162

# SR Analysis: Direct filtered-mono light in end station

Beam configuration: Direct filtered SR beam goes above the hutch stopper to hit the hutch wall

Shielding requirement calculation:

- Unfiltered spectrum was generated using SPECTRA code
- Filtered mono flux, including harmonics, was calculated by applying mirror reflectivity and mono crystal Si(111) bandwidth analytically
- Dose rates at different shielding thickness was calculated using exponential attenuation law and ICRP74 fluence-to-dose conversion coefficients

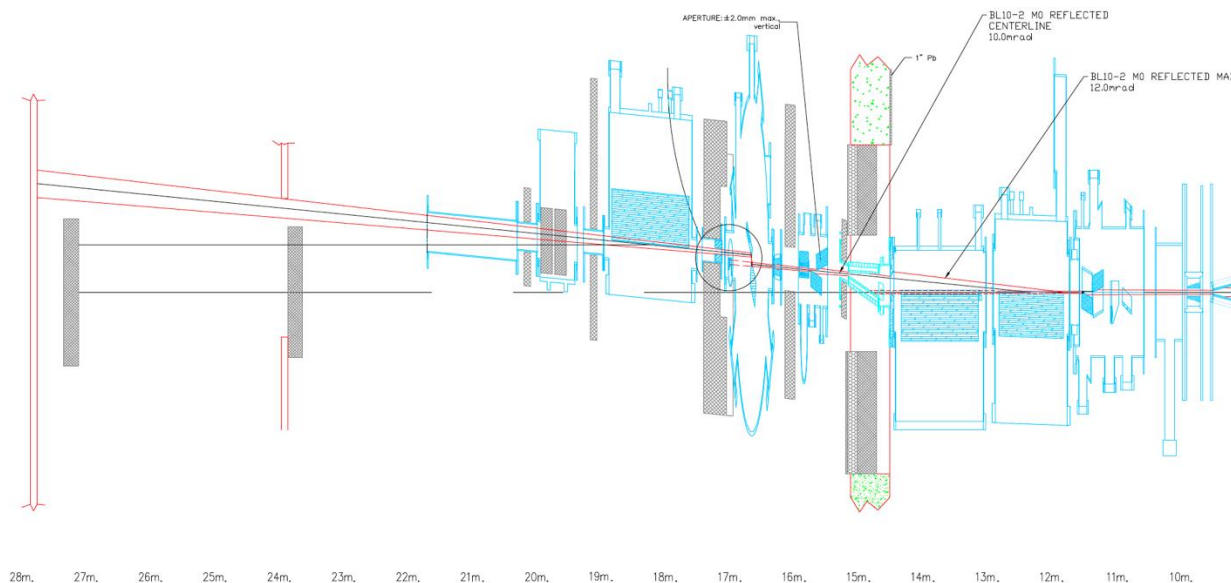

SR ray trace with M0-mirror pitched at maximum angle (5 mrad)

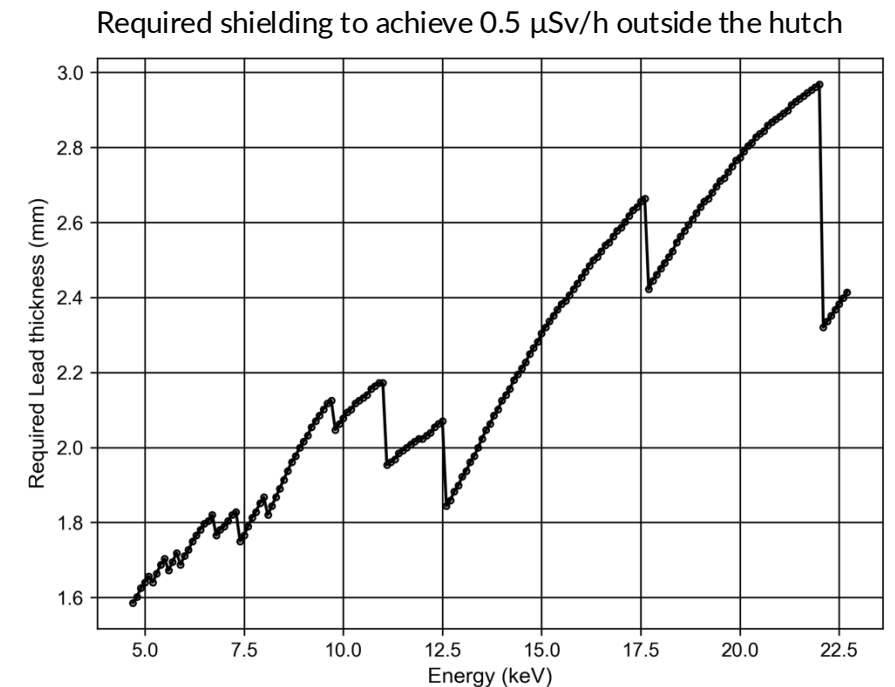

➤ Hutch wall thickness of 3.5 mm is sufficient

# FLUKA calculation vs Commissioning Survey

GB dose rate

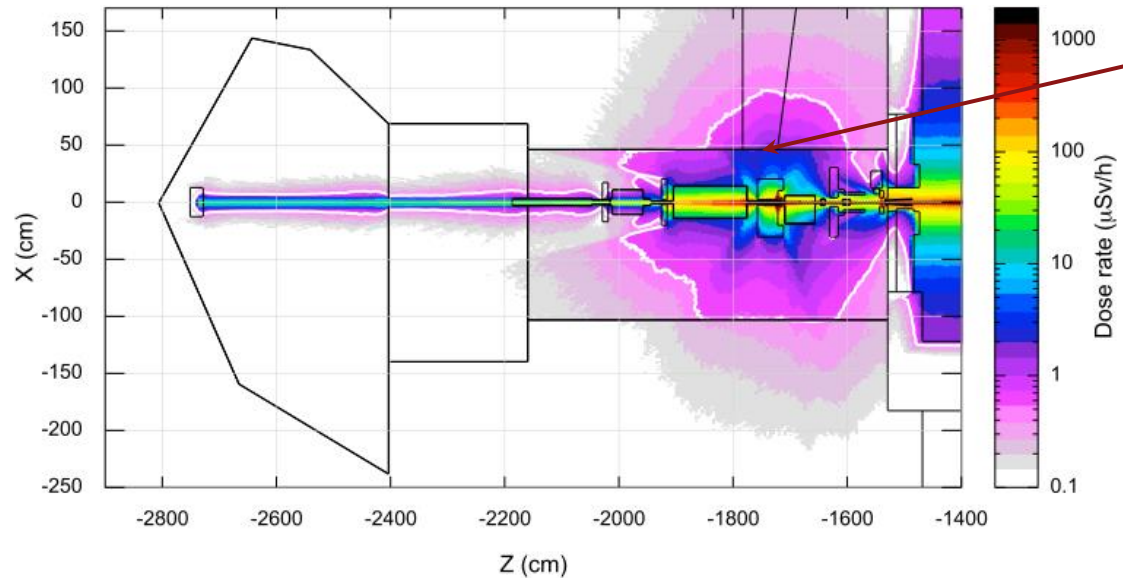

At 30 cm:  $0.9 \mu\text{Sv/h}$   
On contact:  $2.0 \mu\text{Sv/h}$

FLUKA-calculated  
(white light mode)

Only location where  
dose rate above  
background was  
measured:  
 $1.3 \mu\text{Sv/h}$  on  
contact

Measured  
(white light mode)

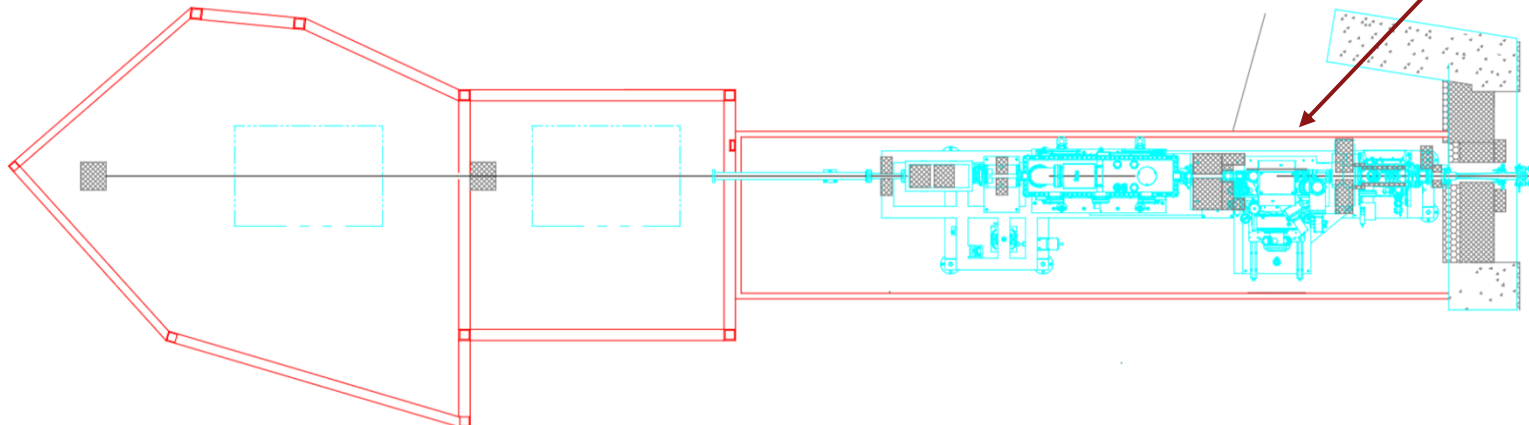

(Note: The SPEAR vacuum pressure is usually  $<0.5 \text{ nTorr}$ , whereas  $1 \text{ nTorr}$  was considered in simulation. Also, 6-m air length used in simulation for the purpose of GB source is conservative)

# Summary

---

- SLAC uses generic radiation safety design to design beamline shielding, which simplify the designs and reduces design time especially during simultaneous multi-beamline designing.
- The detailed shielding analysis for BL10 showed that, although generic radiation safety design mostly met SLAC design limits, some adjustments or optimizations were needed for the final shielding design.
- SSRL BL10 was upgraded and successfully commissioned in 2025.

# Acknowledgement

---

Work supported by Department of Energy contract DE-AC02-76SF00515

Thank you!  
Questions/Comments?